

Hybrid Inverter User Manual

GEN3-LB-EU 3-8K
GEN PRO-LB-EU 8-12K

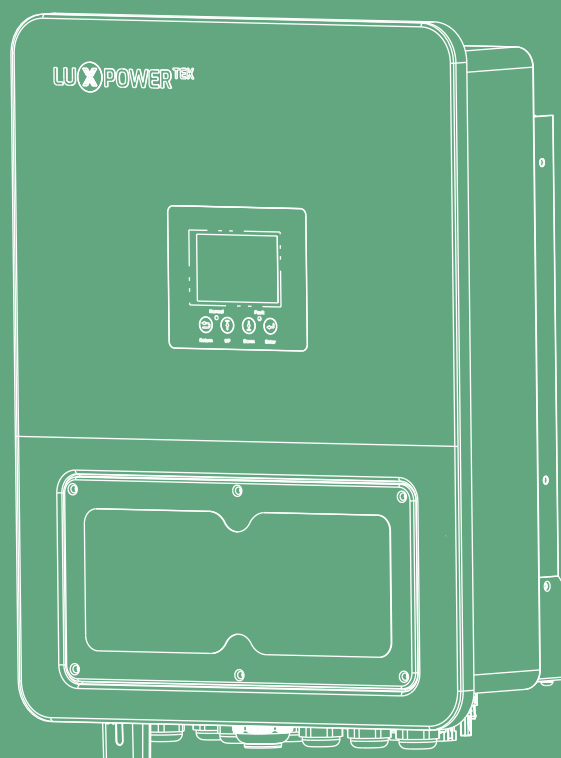

LUXPOWER ^{TEK}

Copyright© 2026 Lux Power Technology Co., Ltd. All Rights Reserved. This manual, protected by the copyright and intellectual property rights of Lux Power Technology. No part of this document may be modified, copied, or reproduced without prior written permission.

All brands and trademarks mentioned belong to their respective owners.

Please read carefully to understand product reliability and warranty eligibility. For detailed warranty information, refer to the Lux Power Technology Co., Ltd Warranty. This manual is intended for professional service providers. Nothing in this document constitutes an express or implied warranty.

Descriptions may include forward-looking statements. Actual conditions may differ. This document is provided for reference only and is subject to change without notice by Lux Power Technology Co., Ltd.



Website



YouTube



Facebook

 www.luxpowertek.com



GEN3&GEN PRO Series

Scan to download

Table Of Contents

Information on this Manual	1
Validity	1
Scope	1
Target Group	1
1. Safety Instruction	1
1.1 Safety Statements	1
1.2 Symbol Conventions	1
1.3 Important Safety Notifications	2
2. Brief Introduction	4
2.1 System Solution	4
2.2 Product Features	5
2.3 Product Dimensions	5
2.4 Product Overview	6
2.5 Packing List	8
3. Handling and Storage	9
3.1 Handling	9
3.1 Storage	9
4. Installation	10
4.1 Precautions	10
4.2 Installation Tools	10
4.3 Location Selection and Installation	11
4.4 Installing the Inverter	12
5. Electrical Connection	14
5.1 Precautions	14
5.2 Connection Overview	15
5.3 Recommended Breakers	15
5.4 Terminal Overview	16
5.5 Battery Connection	17

5.6 Ground Cable Connection 21

5.7 AC Cable Connection 22

5.8 PV Connection 25

5.9 CT/Meter connection 26

5.10 GEN Port Function 31

5.10.1 Generator Connection 31

5.10.2 Smart Load 35

5.10.3 AC Coupling 36

5.11 Parallel Connection 39

5.12 Monitor System Setup 42

6. Operation Guide 44

6.1 Working Mode 44

6.2 LCD Display 52

6.3 LCD Screen Settings 58

7. Troubleshooting & Maintenance 61

7.1 Start and Shutdown the Inverter 61

7.2 Regular Maintenance 62

7.3 Removing the Inverter 63

7.4 LED displays 63

7.5 Trouble Shooting & Error List 64

7.6 Fan Replacement 66

8. Specification 67

Revision History

Version	Date	Description
UM-GEN04001E01	2026.02.05	First official release.
UM-GEN04001E02	2026.05.12	New models and related information added.

Information on this Manual

Validity

This manual is valid for the following devices:

GEN3-LB-EU 3K, GEN3-LB-EU 3.6K, GEN3-LB-EU 4K, GEN3-LB-EU 4.6K, GEN3-LB-EU 5K,
GEN3-LB-EU 6K, GEN3-LB-EU 6.5K, GEN3-LB-EU 7K, GEN3-LB-EU 8K;
GEN PRO-LB-EU 8K, GEN PRO-LB-EU 10K, GEN PRO-LB-EU 12K.

Scope

This manual provides comprehensive product information and step-by-step installation instructions for the GEN3-LB-EU 3-8K series and GEN PRO-LB-EU 8-12K series hybrid inverter. The product is developed and manufactured by Shenzhen Lux Power Technology Co., Ltd. (hereinafter referred to as “LuxpowerTek”).

Before using this product, please read this manual carefully and keep it for future reference.

Target Group

This manual is intended for both professionals and end users. Professionals and end users should possess the following knowledge and skills:

- Understanding of the operating principles of this device.
- Training in installation and electrical safety.
- Experience in installing and commissioning electrical equipment and systems.
- Familiarity with applicable local standards and regulations.

1. Safety Instruction





1.1 Safety Statements

This inverter is designed in compliance with international safety standards. Before installation, operation, or maintenance, please read this manual thoroughly and follow all safety warnings. Installation and operation must comply with local laws and industry standards. The safety information provided in this manual serves as supplementary guidance and does not replace local regulatory requirements.





Failure to use this equipment under the prescribed conditions may result in personal injury, equipment damage, or property loss. Such incidents are not covered under the warranty.

1.2 Symbol Conventions

The following symbols used in this document have the following meanings:

 DANGER	 WARNING	 CAUTION	 NOTICE
Indicates an extremely hazardous situation. Failure to observe this warning may result in serious injury or death.	Indicates a potentially hazardous situation. Failure to observe this warning may result in serious injury or death.	Indicates a situation that may cause minor or moderate personal injury if proper precautions are not taken.	Indicates a potentially hazardous condition that may result in equipment damage or property loss if ignored.

The symbols present on the nameplate of the HYBRID inverter convey the following meanings:

	Surface Temperature Warning. The inverter may produce heat while in operation. Avoid touching.
	High Voltage Warning. The inverter contains high internal voltage, presenting a life-threatening hazard.
	Electric Shock Warning.
	High Voltage Warning. Before performing any operations, ensure that the residual voltage within the inverter is discharged for a duration of 5 minutes.
	Please adhere to the documents attached.

1.3 Important Safety Notifications

There are many safety issues need to be carefully notified before, during and after the installation, and also in future operation and maintenance. The following are important safety notifications for the operator, owner and user of this product under normal conditions of use.

DANGER

Dangers of High Voltages and Large Current

- Beware of high PV voltage. Please turn-off the DC switch of PV Panel output before and during the installation to avoid electric shock.
- Beware of high grid voltage. Please turn-off the AC switch of grid connection before and during the installation to avoid electric shock.
- Beware of large current of the battery output. Please turn-off the battery module before and during the installation to avoid electric shock.
- Do not open the inverter when it's working to avoid electric shock and damages from live voltage and current from the system.
- Do not operate the inverter when it's working, only the LCD and buttons can be touched in limited cases by qualified personnel, other parts of the inverter can be touched when the inverter is under a safe state (e.g. fully shut-down).
- Do not connect or disconnect any connections (PV, battery, grid, communication etc.) of the inverter when it's working.
- Make sure the inverter is well grounding, an operator should make sure himself is good protected by reasonable and professional insulation measurements (e.g. personal protective equipment (PPE)).
- Inspect relevant existing wiring on-site of the installation is in good condition before installation, operation or maintenance.
- Inspect the connections are good between inverter and PV, battery and grid during installation to prevent damages or injuries caused by bad connections.

⚠ DANGER

- Before performing maintenance, turn off the AC circuit breaker on the grid side first, then turn off the battery breaker, and finally switch off the PV DC breaker. Confirm that all indicator lights are off.
- After power-down, wait at least 5 minutes and use proper testing equipment to confirm that internal voltage has dropped to zero before beginning maintenance with protective gear.
- Even after shutdown, the inverter may still be hot to the touch. Allow sufficient cooling time, and always wear insulated gloves when handling the unit.

⚠ WARNING**Avoid Misoperation and Inappropriate Usage**

- All the work of this product (system design, installation, operation, setting, configuration and maintenance must be carried out by qualified personnel as required.
- All connections must be in accordance with local and national regulations and standards.
- The inverter and system can inter-connected with the utility grid only if the utility grid permits it.
- All the warning labels or nameplates on the inverter must be clearly visible and must not be removed, covered or pasted.
- The installation should consider the safety of future users when choosing the right position and location as specified in this manual.
- Please keep the children away from touching or misusing the inverter and relevant systems.
- Beware of burning hurt, the inverter and some parts of the system could be hot when working, please do not touch the inverter surface or most of the parts when they are working. During inverter working states, only the LCD and buttons could be touched.

● NOTICE**Avoid Misoperation and Inappropriate Usage**

- Please carefully read this manual before any work is carried out on this inverter, the installation, please keep this manual carefully stored and easy to access at any time.
- The qualified personnel should have had training in the installation and commissioning of the electrical system as well as dealing with hazards, also they should have the knowledge of the manual and other related documents. As the installer or operator they are required to be familiar with local regulations and directives.

2. Brief Introduction

2.1 System Solution

This product and relevant system is suitable for following system applications (system diagram):

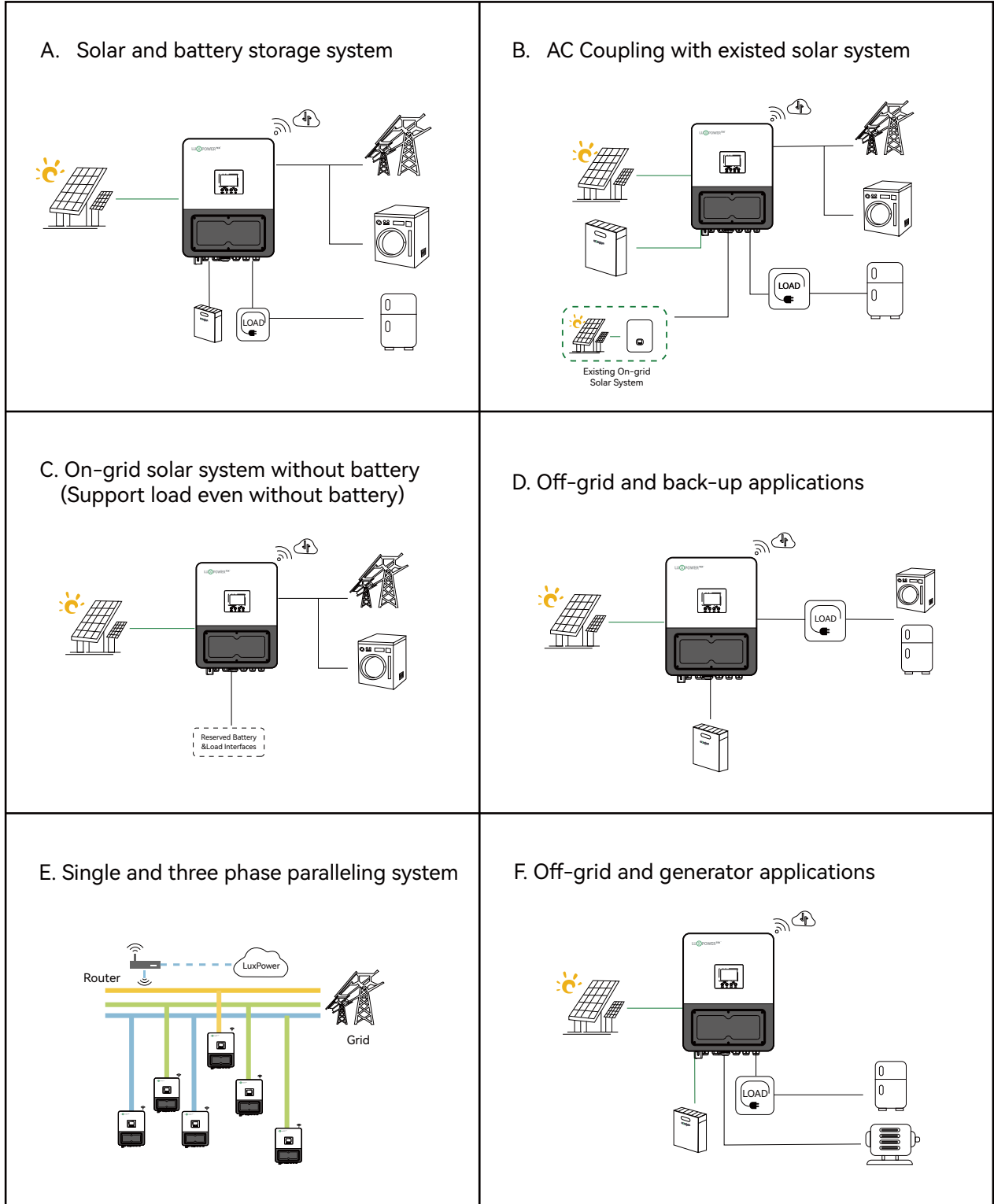

2.2 Product Features

- **Multi-functional High-frequency Pure Sine Wave Hybrid Inverter:** Output power from 3 kW to 12 kW, meeting the needs of medium to large residential energy storage systems.
- **Next-generation Optimized Internal Structure:** The overall structure has been comprehensively upgraded with an optimized layout, significantly improving ease of transportation, installation, and maintenance.
- **IP66 Weatherproof Design:** Durable outdoor-ready enclosure ensures reliable performance in harsh environments, including dust, rain, and high humidity.
- **Versatile Energy Solutions:** Designed for grid-tied operation, backup power, and self-consumption optimization, with flexible energy management for different scenarios.
- **Dual MPPT Design:** Supports up to 12 kW PV input with 2 independent MPPTs(GEN3 series) and 21 kW PV input with 3 independent MPPTs(GEN PRO series) for enhanced energy generation efficiency.
- **Power Factor 0.6~1.0:** Ensures high-efficiency output.
- **Flexible Battery Configuration:** Supports operation with or without batteries.
- **Dedicated Generator Port:** Enables remote start/stop control of generators.
- **Hybrid Power Supply:** PV and grid power can simultaneously supply the loads.
- **Scalable Parallel Operation:** Supports up to 16 inverters in parallel for flexible capacity expansion.
- **Smart Battery Management:** Compatible with mainstream lithium-ion battery BMS via CAN/RS485 communication.
- **Remote Monitoring & Upgrade:** Supports remote monitoring and firmware upgrade via the dedicated WiFi communication dongle, with access through the free mobile APP (iOS/Android).
- **Newly Upgraded Touch Color Display:** An intuitive and clear user interface enables real-time monitoring of operating status and allows quick and convenient inverter configuration.
- **Seamless UPS Switching:** Ultra-fast switching time (7 ms) ensures uninterrupted power supply for critical loads.
- **Time-of-Use (TOU) Optimization:** Supports up to 8 configurable charge and discharge periods to reduce electricity costs.

2.3 Product Dimensions

The overall dimensions of the inverter are shown in the figure below (unit: mm):

(GEN3-LB-EU 3-8K)

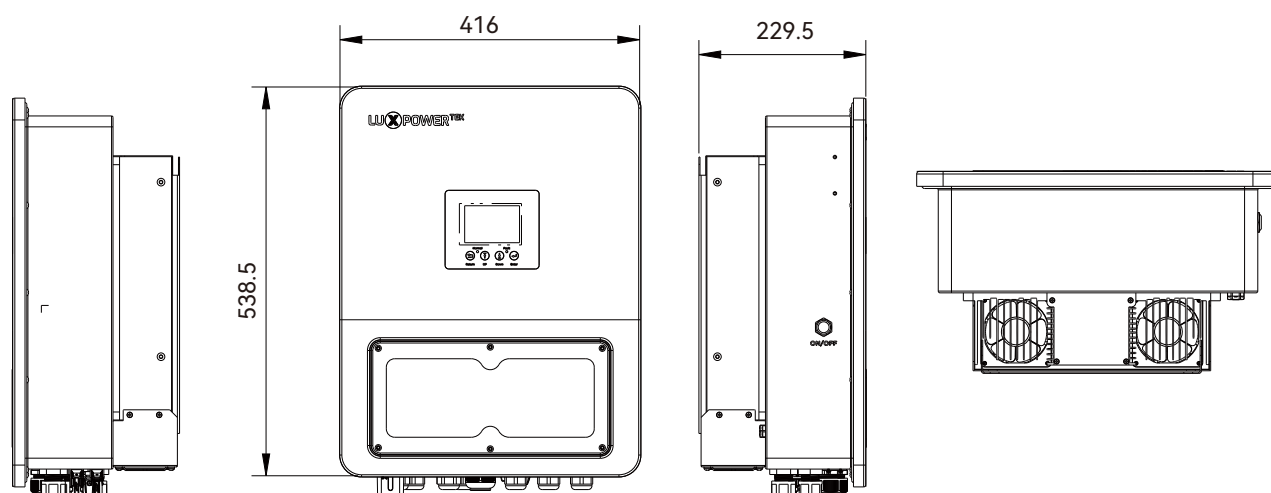

(GEN PRO-LB-EU 8-12K)

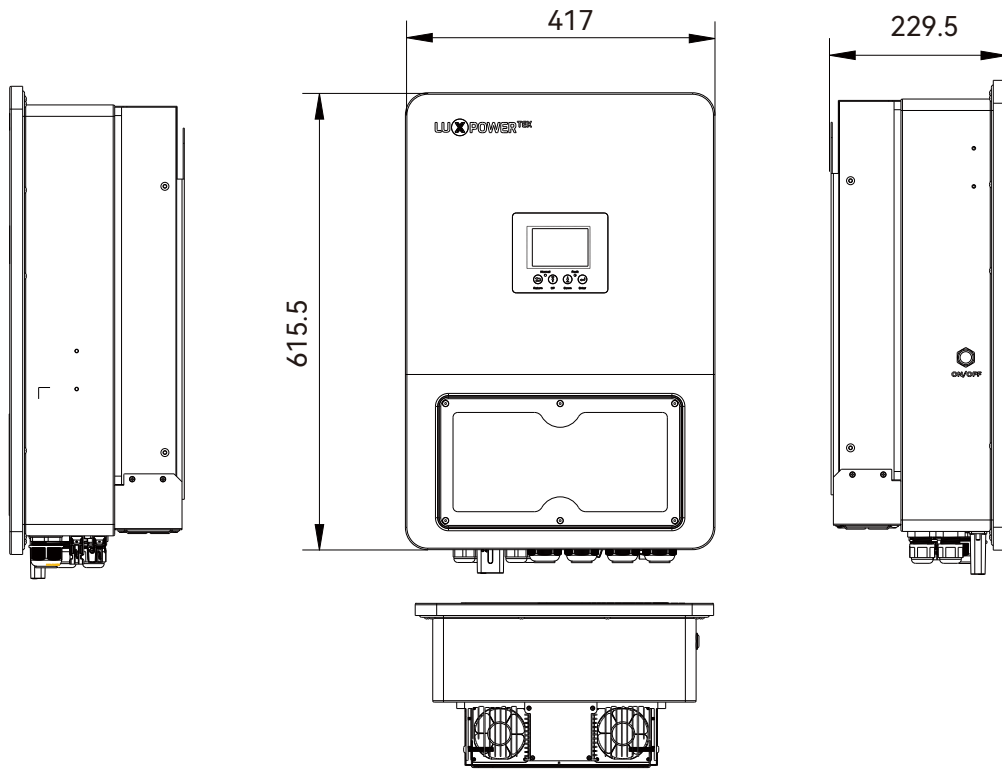

2.4 Product Overview

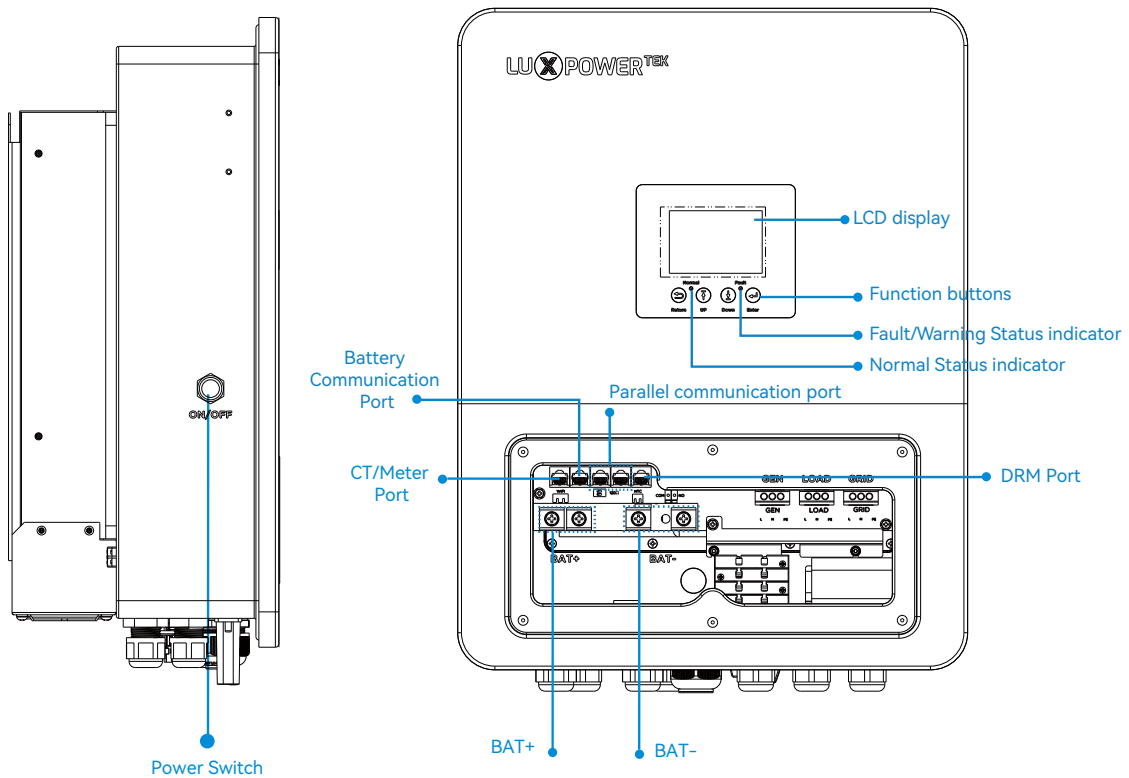

(GEN3-LB-EU 3-8K)

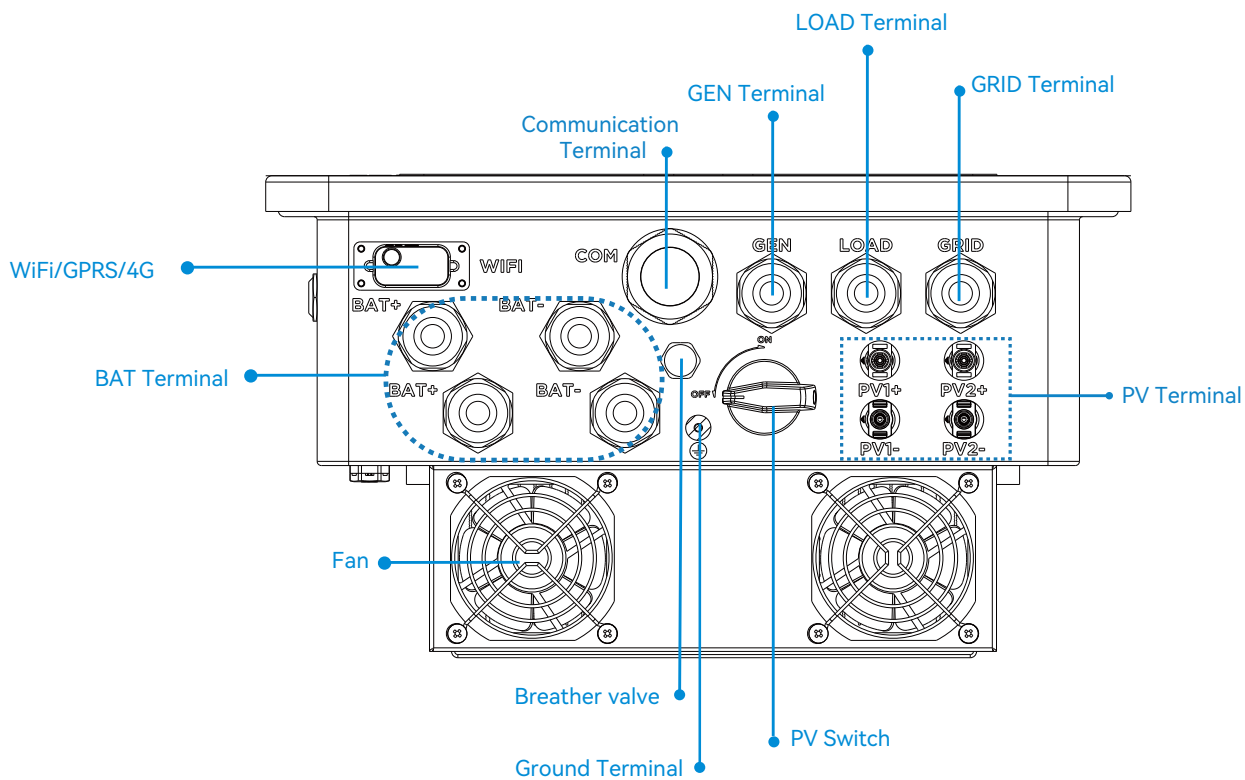

(GEN PRO-LB-EU 8-12K)

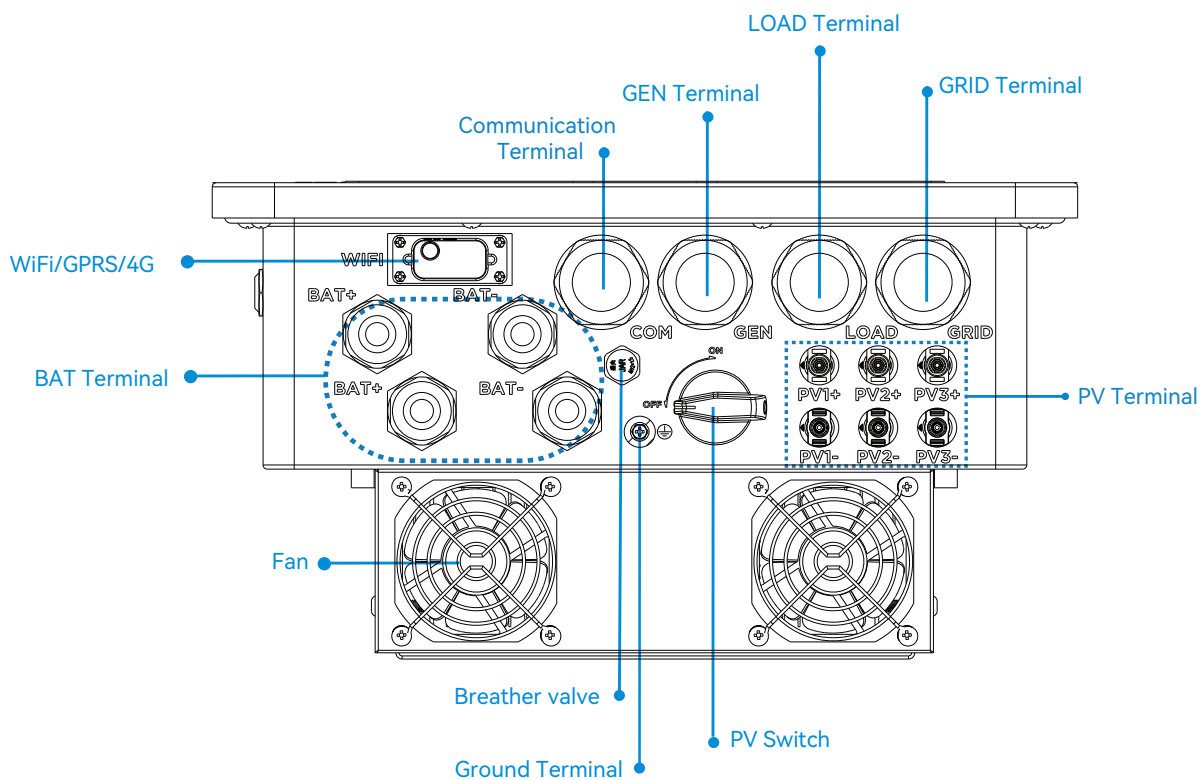

2.5 Packing List

When the packaging is unpacked, the inner components should match those listed in the list below.

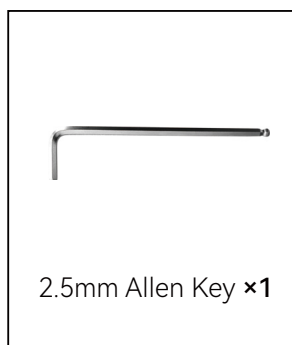
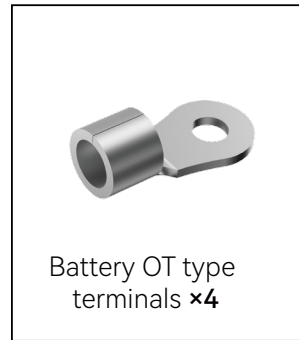
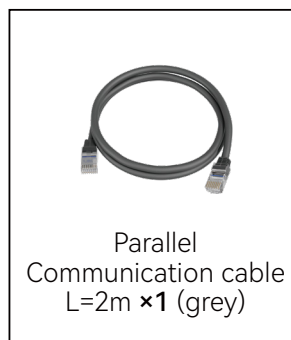
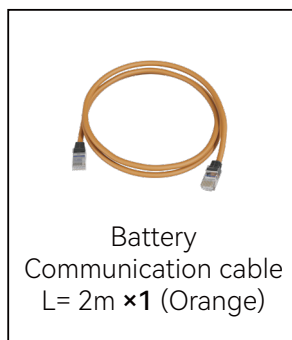
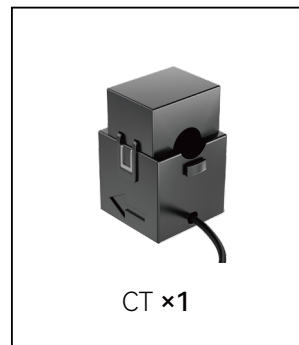
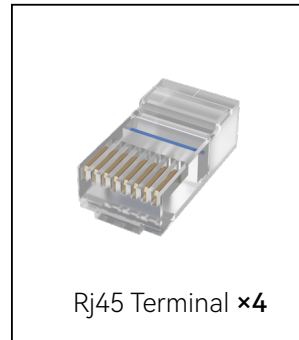
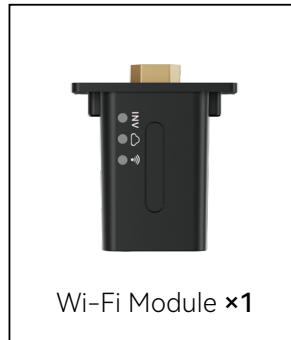
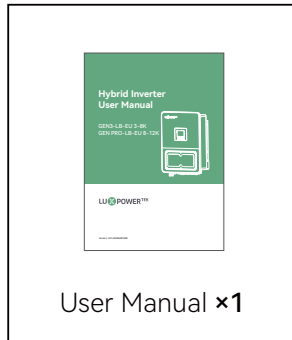

3. Handling and Storage

3.1 Handling

Improper handling may cause personal injury!

- Before handling, carefully check the symbols and markings on the inverter packaging and follow the indicated direction.
- When handling manually, wear protective gloves to avoid injury.
- The inverter is heavy; at least two people are required for manual handling, and the lifting capacity must be confirmed beforehand.
- Move the inverter to its designated installation location before unpacking or installation.
- Do not place the inverter directly on a hard surface, as this may damage its metal casing. Place a protective pad such as foam or sponge underneath.
- Always hold the inverter by its designated handles during transport. Do not lift or carry the inverter by its terminals.
- Do not place heavy objects on top of the inverter under any circumstances.

3.2 Storage

If the inverter is not to be used immediately, it should be kept inside its original packaging and stored in a well-ventilated, dry environment.

- The inverter and all its accessories must remain in their original packaging until installation.
- Storage temperature: -40°C to 65°C ; relative humidity: 0–100%.
- Packages must be stored upright and may be stacked up to seven (7) layers high.
- Do not expose the inverter or its packaging directly to sunlight, rain, or high humidity.
- Keep the inverter away from corrosive, dusty, or chemically reactive environments.



4. Installation

4.1 Precautions

 Do not install the inverter in the following environments:

- Under direct sunlight.
- Areas where flammable or explosive materials are stored.
- Potentially explosive atmospheres.
- Locations directly exposed to cold air outlets.
- Near television antennas or antenna cables.
- At altitudes above 2000 m.
- Areas subject to rainfall.
- Installation within 1 km of coastal areas with high salt spray is not recommended, as it may affect the product's reliability and service life.

4.2 Installation Tools

Recommended tools for installation:

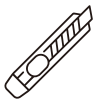
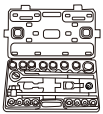
				
Protective goggles	Anti-dust mask	Earplugs	Work shoes	Work gloves
				
Percussion drill	Utility knife	Marker	Slotted screwdriver	Cross screwdriver
				
Pliers	Socket wrenches set	Rubber hammer	Wire cutter	Level
				
Anti-static wrist strap	Wire stripper	Heat gun	Hydraulic pliers	Allen Key
				
Crimping tool 4–6 mm ²	Solar connector wrench	Multimeter ≥1100 VDC	RJ45 crimping plier	Cleaner

4.3 Location Selection and Installation

- a). The wall for mounting should be strong enough to bear the weight of inverter.
- b). Please maintain the minimum clearances below for adequate heat dissipation.

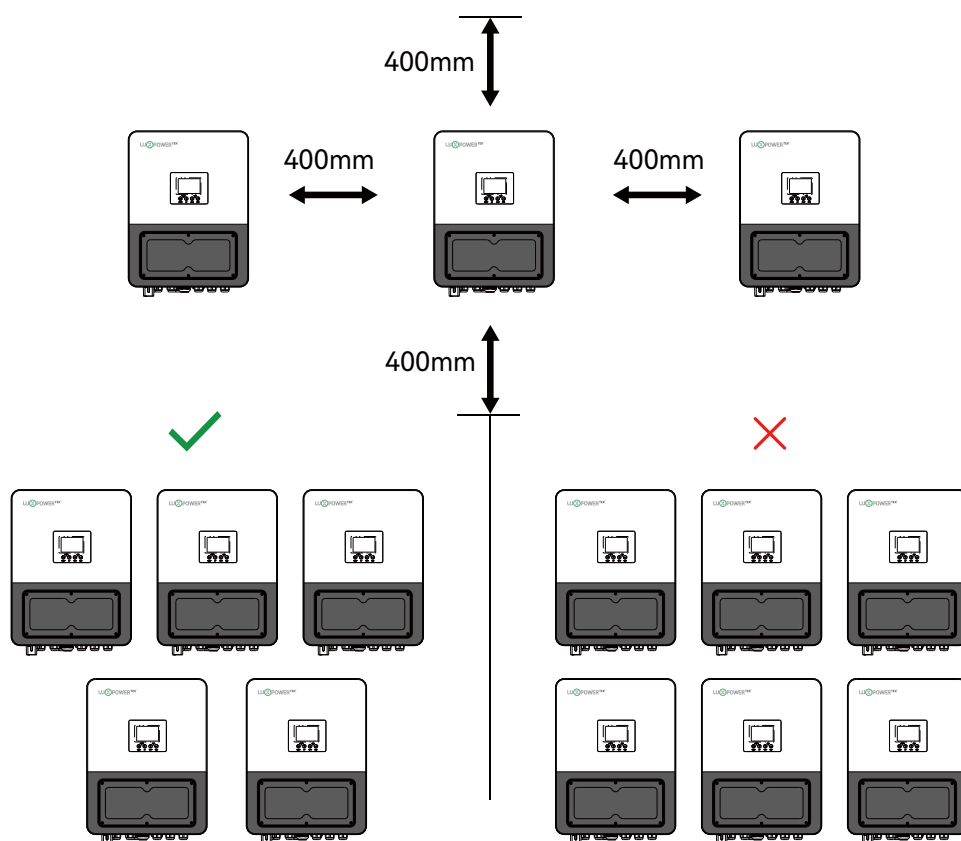

- c). Never install the inverter in a place with direct sunlight, rain or snow. Please refer to below figure and select a well shaded place or install a shed to protect the inverter fro direct sunlight, rain and snow etc. PROTECT the LCD screen from excessive UV exposure.

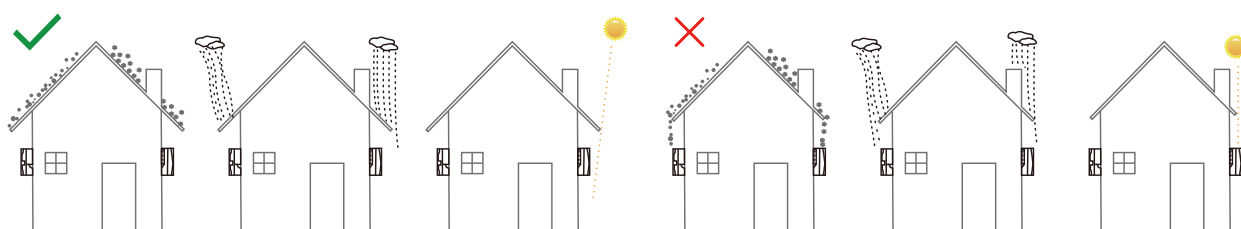

d). The inverter should be installed upright on a vertical surface.

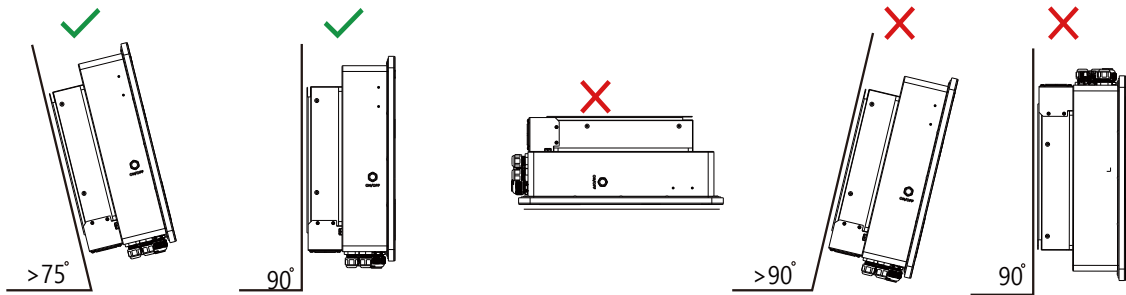

4.4 Installing the Inverter

This inverter is designed for wall-mounted installation. It must be installed on a solid vertical surface, such as a concrete wall, brick wall, or wooden structure. Due to the weight of the inverter, it is recommended that at least two people perform the installation.

Please remove the wall-mount bracket from the back of the inverter before installation.

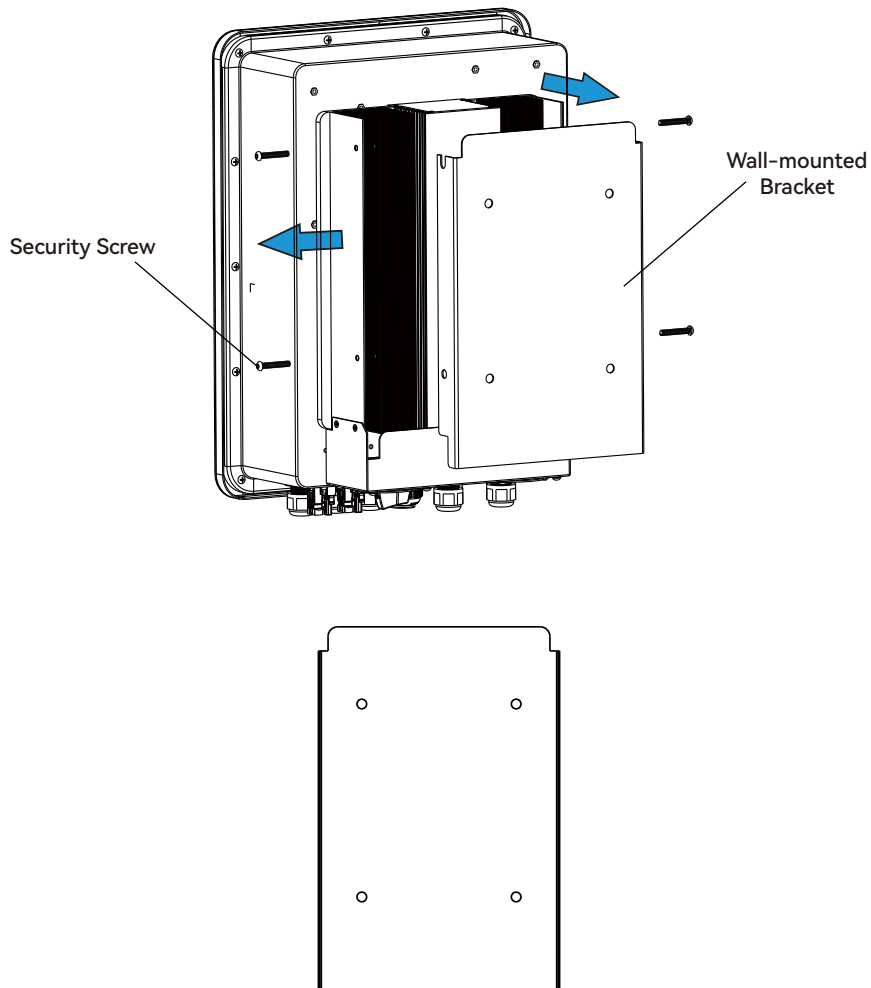

Installation Steps (Brick Wall Example)

Step 1. Mark and drill holes. Use the wall-mounting bracket to mark the hole positions on the wall. Drill 4 holes with a diameter of 8 mm (5/16 inch) and a depth of at least 50 mm (2 inches).

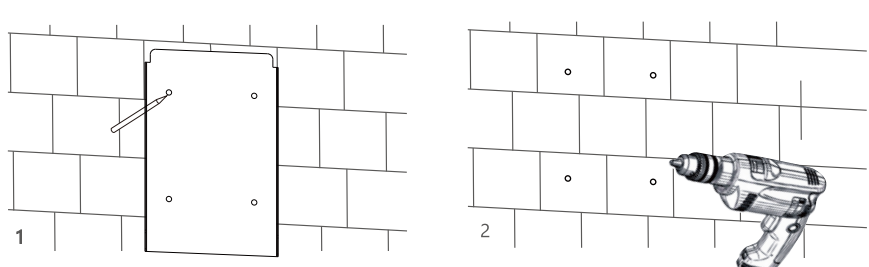

Step 2. Install expansion bolts and bracket. Insert the expansion bolts into the drilled holes. Fix the wall-mounting bracket onto the wall using the provided nuts and washers, and ensure it is securely tightened.

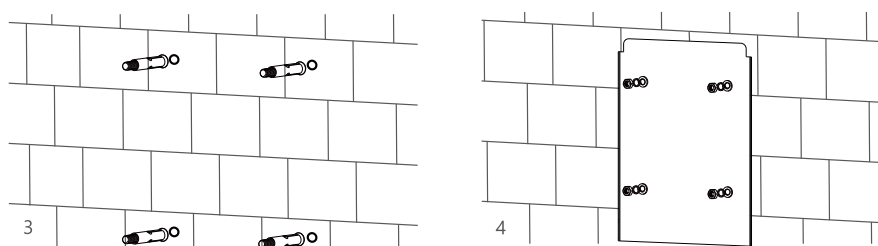

Step 3. Mount the inverter. Hang the inverter onto the wall-mounting bracket. Secure the inverter by tightening the hex socket countersunk screw on the right side of the heatsink.

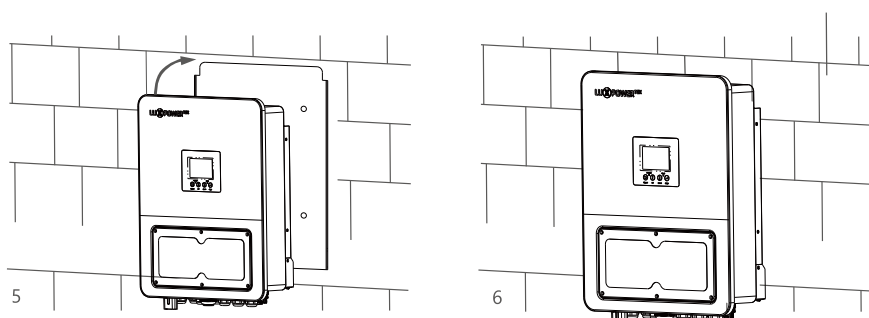

Installation on Wooden Wall / Studs

Fix the mounting bracket onto the wooden studs using appropriate wood screws. Then hang the inverter onto the bracket and secure it using self-tapping screws.

Note: Wood screws and self-tapping screws are not included and should be prepared by the installer.

5. Electrical Connection

5.1 Precautions

During electrical operations, personnel with expertise must wear appropriate protective equipment.

DANGER

- Caution: High voltage is present within the inverter!
- Warning: Photovoltaic strings exposed to sunlight can generate hazardous voltages.
- Before completing any electrical connection, make sure the PV Switch, System Switch, and AC Breaker are all disconnected
- Before conducting electrical connections, ensure that all cables are de-energized.

WARNING

- Improper wiring operations may cause equipment damage or personal injury.
- All wiring operations must be performed independently by qualified technicians.
- Throughout the electrical connection process, use insulated tools and wear PPE.
- Cables used in the PV power system must be securely connected, in good condition, properly insulated, and meet the specified ratings.
- Strictly follow the connection instructions provided in this manual or other relevant documents.
- Any inverter damage caused by incorrect wiring is not covered under warranty.

CAUTION

- The wiring process must comply with the safety instructions of the PV modules.
- All electrical installations must conform to the national or regional electrical standards of the installation site.

5.2 Connection Overview

The system connection diagram is as below:

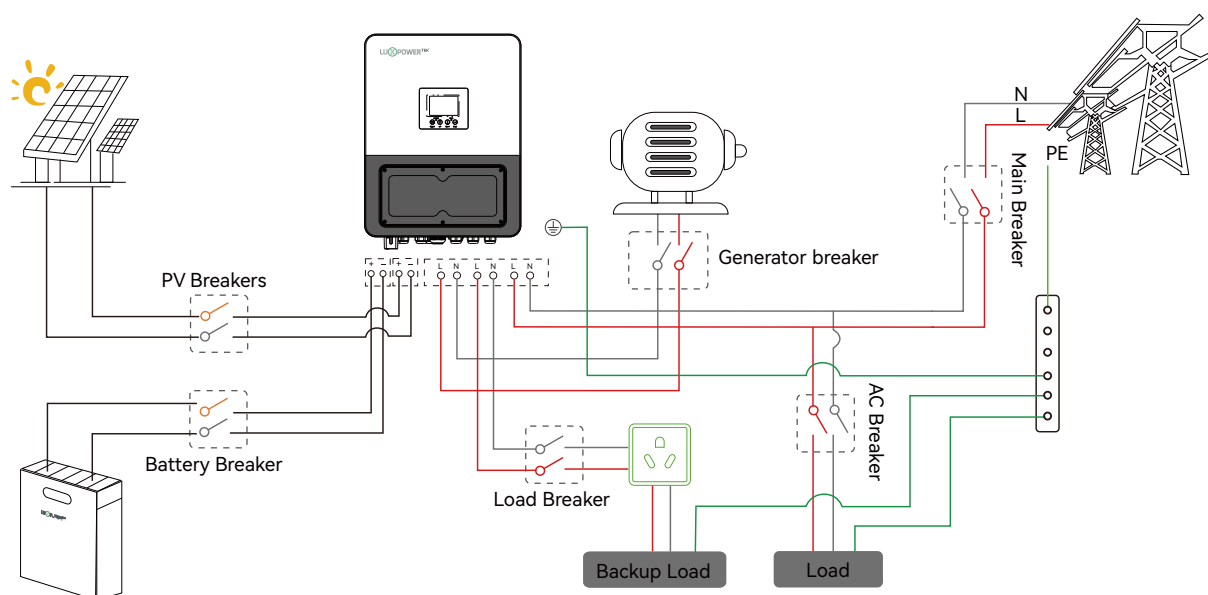

NOTICE

1. Max. AC input current: 52.7A(GEN3 series), 100A(GEN PRO series).

2. About the "Load" terminal on the Inverter

In our inverter system, there is a port labeled "Load," which is specifically used to connect essential loads. On the inverter's LCD screen, this terminal is labeled as "EPS Load", indicating Emergency Power Supply.

In some sections of our manual, this terminal is also referred to as "Essential Load."

Regardless of the term used, these all refer to the same port, which functions to ensure that, in the event of a power outage, the connected critical loads can continue to be powered by solar panels or the storage battery, thereby maintaining the operation of essential devices.

5.3 Recommended Breakers

Inverter model	GEN3-LB-EU 3-8K	GEN PRO-LB-EU 8-12K
PV Breakers (2P×2)	600V/25A	-
PV Breakers (2P×3)	-	600V/25A
Battery Breaker (2P)	100V/250A	100V/300A
Main Breaker (2P)	63A/230Vac	125A/230Vac
Load Breaker (2P)	63A/230Vac	125A/230Vac
Generator breaker	63A/230Vac	100A/230Vac

5.4 Terminal Overview

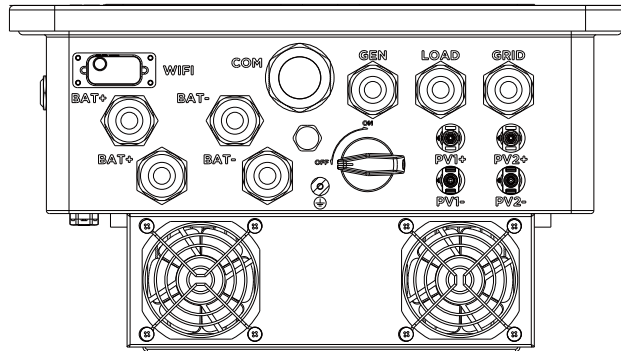

(GEN3-LB-EU 3-8K)

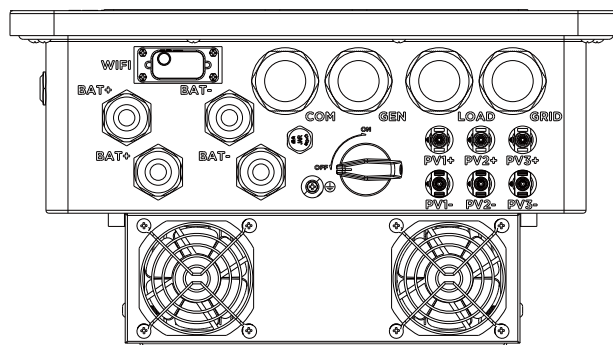

(GEN PRO-LB-EU 8-12K)

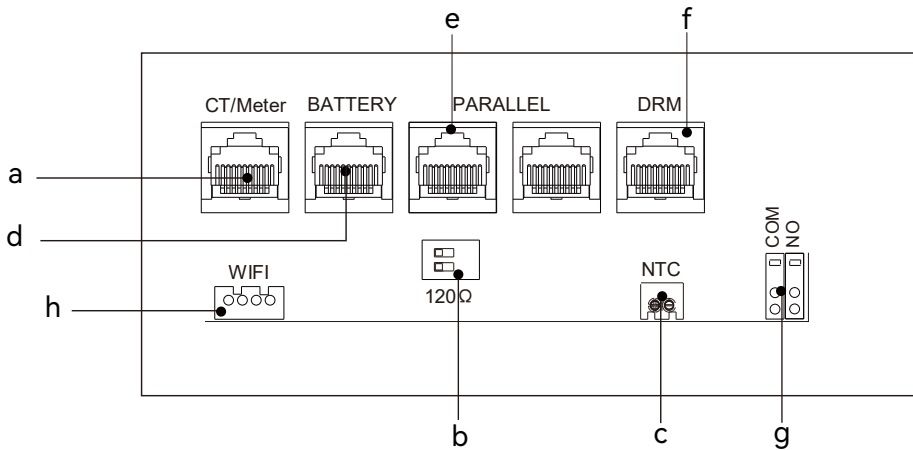

a	For detailed interface definitions of CT&METER 485 and INV 485, please refer to section 5.9.
b	CAN Matching resistance: Set DIP switch when use inverters in parallel
c	Connection for temperature sensor of lead-acid battery
d	Battery communication port (CAN&RS485) please check Chapter 5.5.2 for Pin definition
e	Parallel communication port. Please check Chapter 5.11 for Parallel connection
f	DRM port: is used for demand response control
g	GEN (NO&COM) : Connection for generator auto-start function
h	Wifi/GPRS/4G/WLAN dongle connection

5.5 Battery Connection

Wiring instructions

Note: For the final installation, circuit breakers complying with IEC 60947-1 and IEC 60947-2 standards must be equipped and installed together with the device.

NOTICE

Before Wiring

- All wiring work must be carried out by qualified professionals to avoid the risk of electric shock.
- Using proper AC input cables is critical for system safety and efficient operation. To reduce the risk of injury, please use the cable specifications recommended in this manual.
- Before performing any wiring operations, remove the bottom cover of the inverter (by loosening the 6 screws shown in the diagram).
- Ensure the inverter is completely powered off before removing the cover.
- Double-check the polarity of all DC cables during wiring.
- Strictly follow the recommended cable sizes and specifications. Incorrect wiring may cause overheating or fire hazards.
- Ensure that all terminals are tightened according to the recommended torque. Loose connections may result in malfunction or damage.

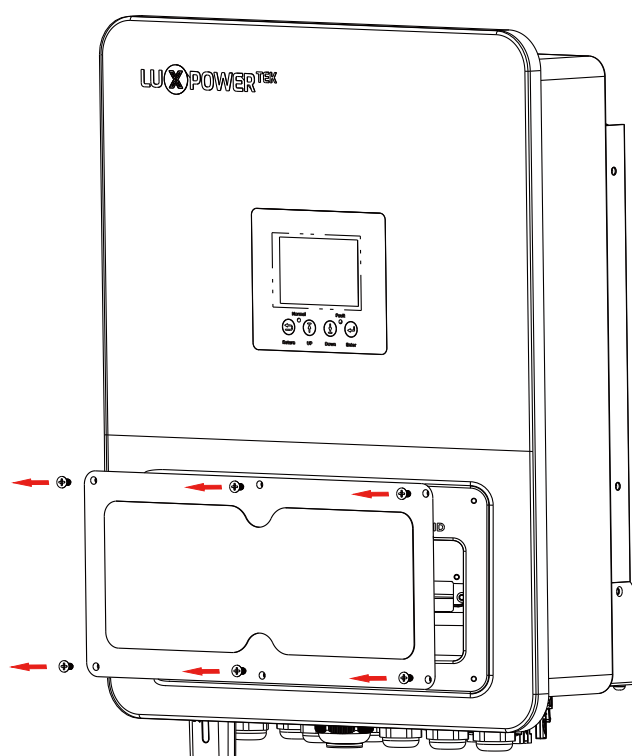

5.5.1 Battery Power Cable Connection

NOTICE

- The cable insulation rating should not be lower than 90 °C.
- Keep the cable length as short as possible to reduce voltage drop.
- The wiring sequence should be: connect the positive (+) terminal first, then the negative (-) terminal. Polarity must be strictly observed during wiring.
- All terminals must be tightened according to the recommended torque to avoid overheating caused by poor contact.
- Use extreme caution when working with metal tools around batteries. Dropped tools may cause sparks, short circuits, or even explosions.
- Put the built-in battery breaker in the off position before connecting or disconnecting batteries.

Cable Requirement:

Model	Cable Size	Minimum Voltage	Torque for cable connection
GEN3-LB-EU 3K/ 3.6K/4K/4.6K/5K	2-3AWG(25-35mm ²)	600V	20(N·m)
GEN3-LB-EU 6K/6.5K/7K/8K	1-2AWG(35-50 mm ²)	600V	20(N·m)
GEN PRO-LB-EU 8K/10K/12K			

Recommended OT terminal: M6(Min.), M8(Max.)

NOTICE

For the GEN3-LB-EU 8K and GEN PRO-LB-EU 10K/12K model, two battery cables must be connected in parallel to both the positive and negative terminals to meet current-carrying requirements and reduce line losses.

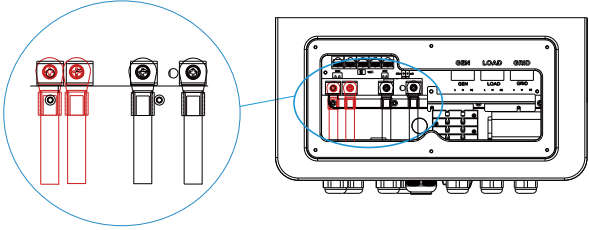

Wiring Procedures:

Step 1: Open the wiring compartment cover. Strip 0.47–0.55 inch (12–14 mm) of insulation from the cable ends and crimp cable lugs onto the ends of the cables.

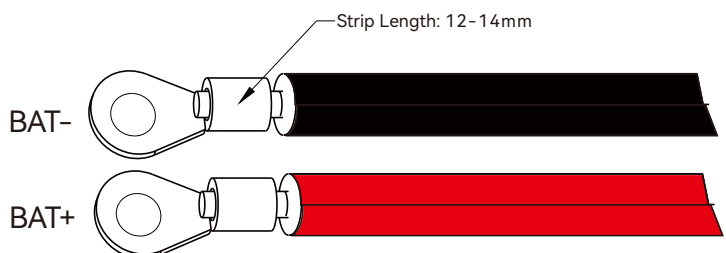

Step 2: Route the battery cables with crimped terminals through the cable gland and into the wiring compartment. Connect the positive cable to BAT+ and the negative cable to BAT-.

Step 3: Fasten the OT terminals of the battery's positive and negative cables to the corresponding lugs according to the polarity markings.

Step 4: Ensure the cable gland is tightened securely to achieve proper waterproof sealing.

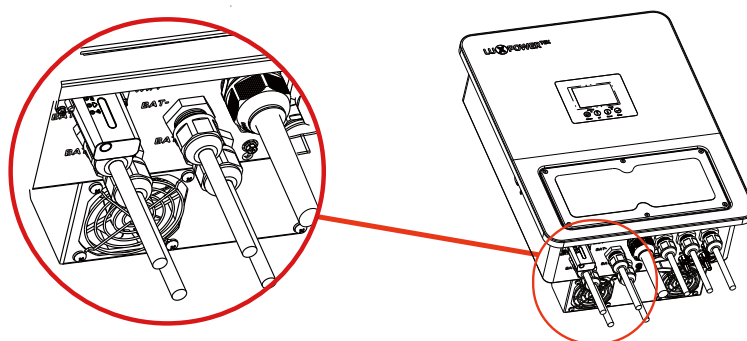

5.5.2 Battery Communication Cable Connection

When using lithium-ion batteries, a correct battery communication cable must be used to connect the battery to the inverter. If the lithium-ion battery cannot communicate with the inverter, please select the “Lead-acid” battery type in the system settings.

The battery communication port on the inverter uses an RJ45 socket. The communication cable must be made according to the RJ45 pinout provided by the inverter and matched with the correct pinout of the battery’s communication port. The inverter supports both CAN and RS485 communication protocols.

Operating Procedures:

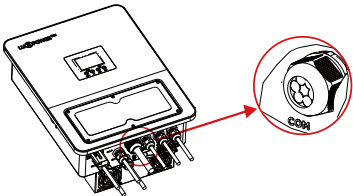
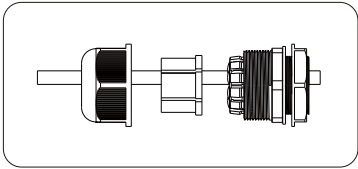
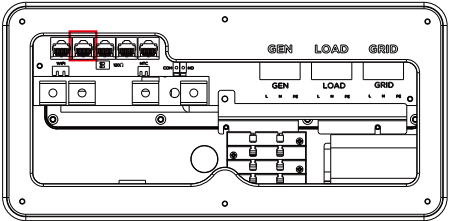
<p>Step 1: Loosen the COM gland nut on the inverter casing, and remove the sealing plug from the cable gland as required. Do not remove the sealing plug from any unused cable entry ports.</p> 	<p>Step 2: Pass the battery communication cable sequentially through the gland nut, cable gland, and connector housing.</p> 
<p>Step 3: Insert the RJ45 connector into the inverter’s internal battery communication port. Finally, tighten the gland nut to ensure a firm and sealed connection.</p> 	

Step 4: If the manufacturer does not provide a dedicated communication cable, crimp the cable yourself according to the PIN definition.

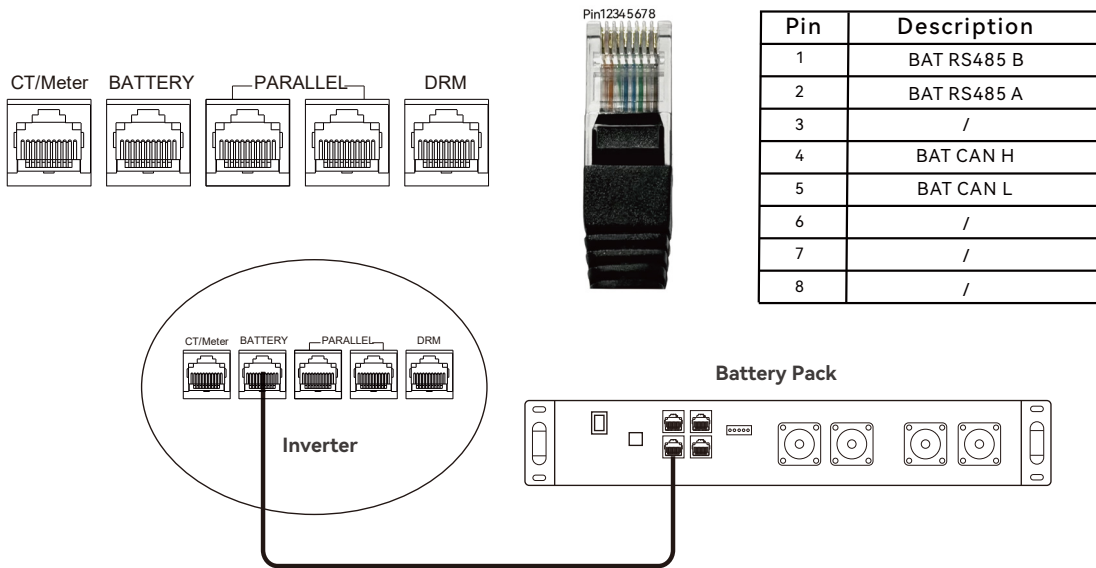

Step 5: Configure the battery type via the LCD: Go to “Battery Setting”→“Battery Type” → Select “Lithium”. In the menu, choose the correct battery brand/model (refer to the LuxpowerTek battery compatibility list).

If using a LuxpowerTek battery, select lithium-ion type for option 6: Luxpower.

After battery power cable and communication cable connection, users need to enter Battery Setting and choose battery type and brand on the inverter LCD.

● NOTICE

For Li-ion battery

- Please make sure the lithium-ion battery to be used is compatible with our inverters. Please contact your distributor for updated battery compatible list.
- If you are using multiple battery modules with the inverter, the inverter communication cable must be connected to the master battery. Please check with your battery supplier for battery master and slave settings.

For Lead-acid battery

- The temperature sensor for lead-acid battery is optional. If you need it, please contact distributor for purchasing.
- There are three stages for lead-acid battery setup. For charging/discharge related parameters, “Settings”→ “Battery Setting”→“Battery Type” (This page will appear only when set to lead-acid battery).

< Battery Type

Battery Type Lithium >

Lithium Type 6: LUX >

Battery ECO Enable

< Battery Type

Battery Type Lead-acid >

Capacity (Ah) 500 >

Charge Voltage (V) 52.1 >

Float Voltage (V) 52.1 >

Equalization Voltage (V) 500 >

Equalization Period (Days) 2 >

5.6 Ground Cable Connection

To ensure electrical safety and proper system grounding, please follow the steps below to install the ground cable to the inverter chassis.

NOTICE

- When using multiple inverters in parallel, all chassis ground cables must be connected to the same grounding point to avoid potential voltage differences.
 - The chassis ground does not replace the PE cable of the AC output. Both connections must be made separately.
 - If local standards require equipotential bonding, use a dedicated grounding busbar to connect PV module frames, racks, and other components accordingly.
- ▲ Proper grounding of the equipment is mandatory. Operation without grounding is strictly prohibited.
- ▲ **WARNING:** Improper grounding may cause electric shock hazards or equipment malfunction. Always comply with local electrical codes and standards.

Name	Cable	Cable Size (mm ²)	OT Terminal	Torque (N·m)
Ground cable	Single-core copper wire (solid or stranded)	6 mm ²	M4	2.0 N·m

Installation Procedures

Step 1: Strip the grounding wire, insert it into the OT terminal, and use a crimping tool to secure it firmly.

Step 2: Use a torque wrench to fasten the OT terminal to the inverter grounding port with a recommended torque of 1.2 N·m (±10%).

Step 3: Verify that all grounding terminals are firmly secured and that wires are not loose.

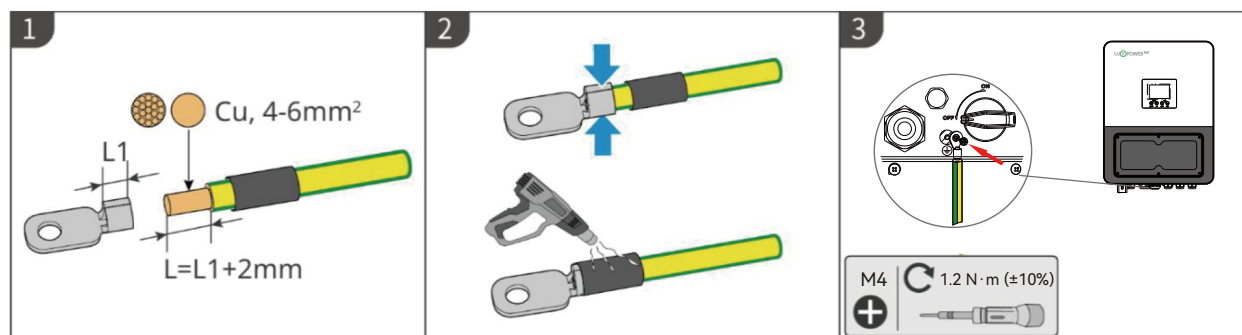

5.7 AC Cable Connection

⚠ CAUTION

- The AC terminals are divided into IN (input) and OUT (output). Do not connect them incorrectly. (**Input port:** Grid and GEN; **Output port:** Load)
- Ensure that L and N are wired with the correct polarity. Reversed wiring may cause a short circuit, especially during parallel operation.
- Before performing AC input/output wiring, make sure the AC power is completely disconnected to avoid the risk of electric shock.
- Use a multimeter to verify that the AC voltage is 0 Vac before proceeding.
- Before connecting the inverter to the grid, approval must be obtained from the local utility company in accordance with national and regional grid-connection regulations.

⚠ The Load Port must not be connected to any type of transformer:

- Connecting a transformer may cause abnormal operation of the inverter’s internal circuits, potentially leading to overload, damage, or safety hazards.
- Only connect household appliances or loads within the rated power.
- For extended applications, strictly follow the official installation guidelines and consult technical support.

5.7.1 Recommended Cable

GEN3-LB-EU 3-8K

Terminal	Cable Size (mm ²)	Minimum Voltage
GRID/LOAD/GEN	8-6 AWG(9-14mm ²)	600V

GEN PRO-LB-EU 8-12K

Terminal	Cable Size (mm ²)	Minimum Voltage
GRID/LOAD/GEN	4-2 AWG(21-33mm ²)	600V

5.7.2 Grid Regulation Selection

Our inverters are compliant with on-grid regulations in several areas, including standards such as EN50549-10, G98, G99, and more. Select the rule that corresponds to your location in Advanced setting.

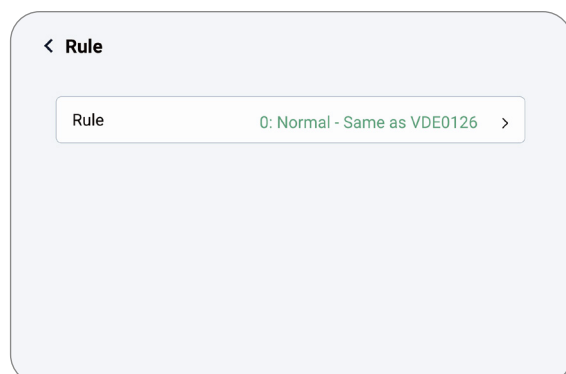

5.7.3 GRID & LOAD Port Wiring

Wiring Procedures

Step 1: Before wiring, make sure that all AC breakers or isolators are turned off.

Step 2: Strip approximately 0.39–0.47 inch (10–12 mm) of insulation from the end of each cable and crimp tubular cable lugs.

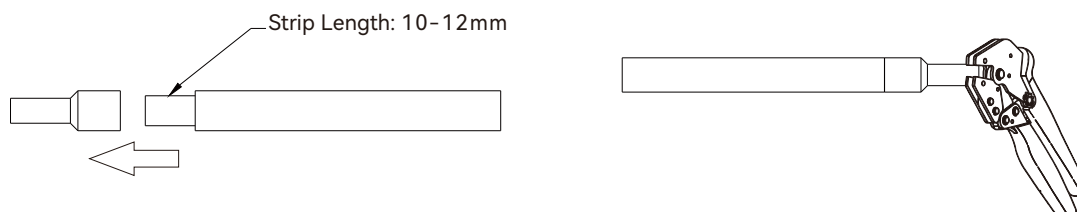

Step 3: Open the wiring compartment and loosen the cable gland. Route the cables through the openings of the cable gland.

Step 4: Refer to the labels inside the wiring compartment and connect the cables to the correct terminals accordingly.

Step 5: Tighten the screws above the terminals to ensure the cables are securely connected.

Step 6: Tighten the cable gland to ensure proper waterproof sealing.

***Note:** Do not remove the rubber plugs from any unused cable gland openings, as this may compromise the waterproof performance.

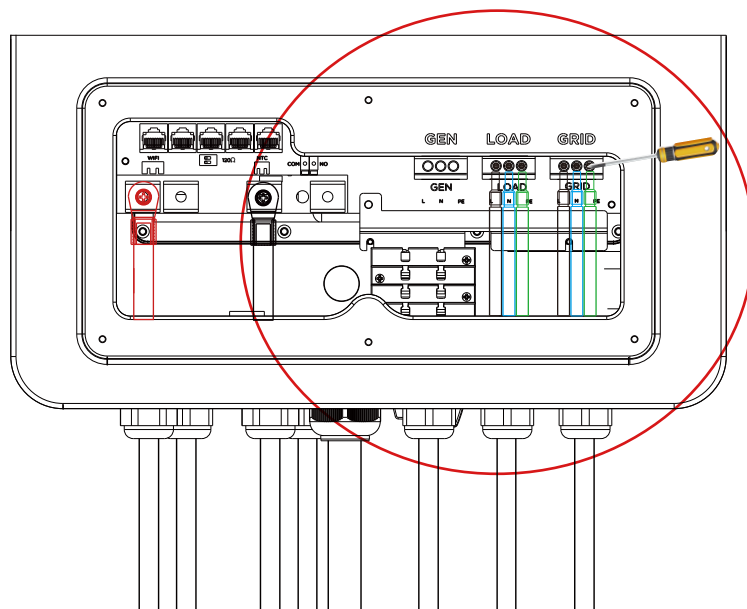
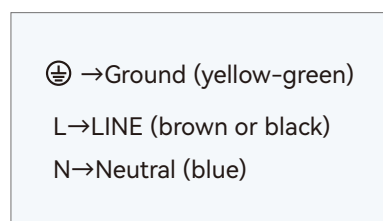

NOTICE

The inverter includes built-in residual current detection and protection.

If an external AC circuit breaker with residual current protection (RCD) is used, select a device with a rated residual current of ≥ 300 mA.

5.7.4 Connection Diagram

The inverter can be connected to the load side of the service disconnecting means if the busbar rating in the main panel can meet the NEC705.12(B)(3) requirements. Otherwise, a Line side connection can be made to avoid an expensive main panel upgrade.

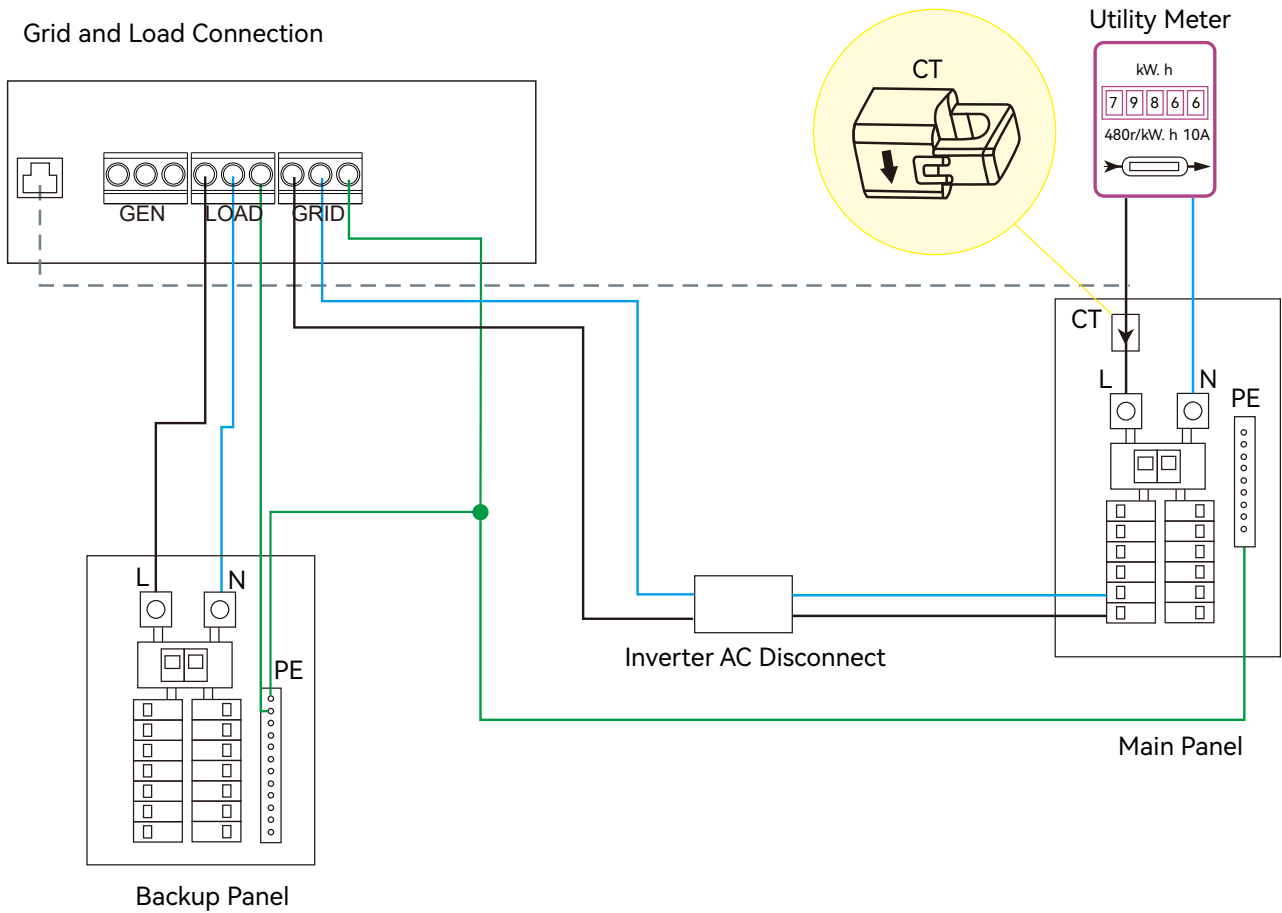

5.8 PV Connection

The PV connection of the GEN3 series hybrid inverter is similar to a standard string inverter.

NOTICE

- Before connecting the PV, use a multimeter to measure the PV array voltage and ensure it is within the acceptable range. Do not proceed with the connection if the PV array is not operating properly.
- In low ambient temperature conditions (below 0°C), the PV array voltage may increase. Verify that the maximum open-circuit voltage (Voc) does not exceed the inverter's limit. If unsure, consult your system installer or panel manufacturer.

Cable Requirement:

Cross-section	Cable Diameter	Minimum Voltage
4 - 6 mm ²	2.4-3.0 mm	600V

Wiring Procedures

Step 1: Turn off or disconnect the PV switch (DC switch). Keep the switch in the OFF position during installation.

Step 2: Assemble the PV connector.

a). Strip 6–8 mm of insulation from the cable end.



b). Crimp the cable ends with the corresponding crimp contacts (positive and negative).

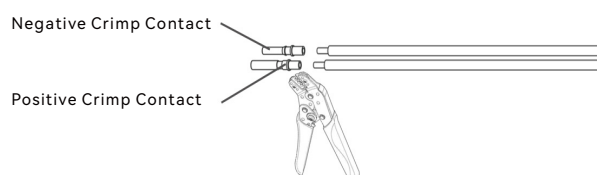

c). Insert the cable through the cable gland, then push the crimped contact into the connector housing until it clicks into place. Tighten the cable gland securely.

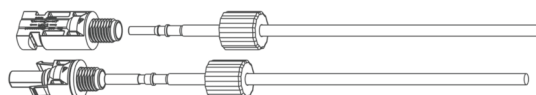

Step 3: Connect the PV connectors. Ensure the connectors are properly assembled.

Align the male and female connectors, then push them together until a “click” is felt or heard.

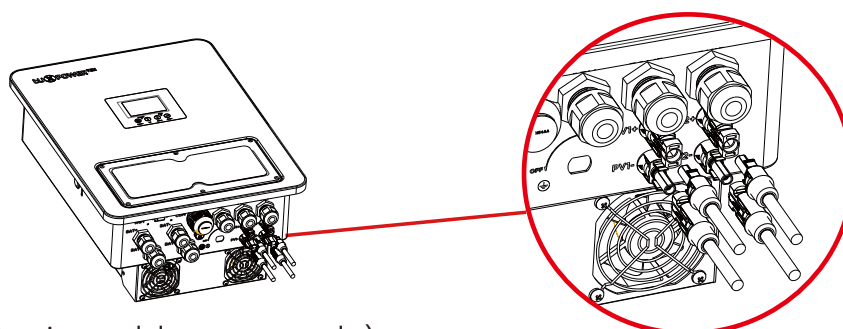

(Using the GEN3 series module as an example.)

NOTICE

- Do not connect PV modules that may cause leakage current to the inverter.
- Grounded PV modules may result in residual current and affect inverter operation.
- Ensure that neither PV+ nor PV- is connected to the system grounding conductor.
- It is strongly recommended to install a PV combiner box with surge protection.
- Without surge protection, lightning strikes may damage the inverter.
- A DC circuit breaker (600 V / 25 A) must be installed between the PV array and the inverter.
- Use UV-resistant, double-insulated cables suitable for outdoor PV applications.
- Ensure that the cable voltage drop does not exceed 2%.
- If the cable length is excessive, increase the conductor size accordingly.
- It is strongly recommended to install a DC isolator switch compliant with IEC 60947-3 or equivalent standards to enhance operational safety.

5.9 CT/Meter Connection

To measure power import from and export to the grid, a CT or energy meter must be installed at the service entry point, typically in or near the main service panel.

One CT is provided as standard for each inverter.

WARNING

Before connecting any AC cables or current transformers (CTs), ensure that all AC power sources are completely isolated to avoid the risk of electric shock.

Installation and Wiring Requirements

- Do not install CT on the neutral (N) or protective earth (PE) conductors.
- Ensure the CT is installed on the correct phase conductor and oriented according to the direction indicated on the CT label.
- Do not install CT on uninsulated conductors.
- After installation, secure the CT clamps and cables using cable ties or suitable fixing methods to prevent loosening or movement.
- The CT cable extension length should not exceed 10 m.
(For longer distances, please consult the device supplier for suitable extension solutions.)

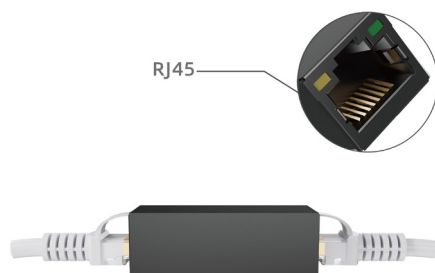

5.9.1 CT Port Pin Definition

The CT interface is an RJ45 port. A pre-assembled RJ45 plug is provided for the CT, allowing direct connection to the port.

Pin	Description
1	Meter RS485 B
2	Meter RS485 A
3	INV RS485 B
4	INV RS485 A
5	CT N
6	CT P
7	CT N
8	CT P

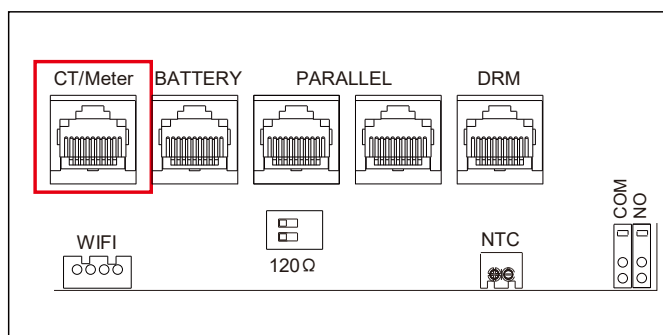

5.9.2 Installation Precautions

- The CT arrow must face toward the inverter.
- Ensure that the CT clamp is securely fastened around the cable.

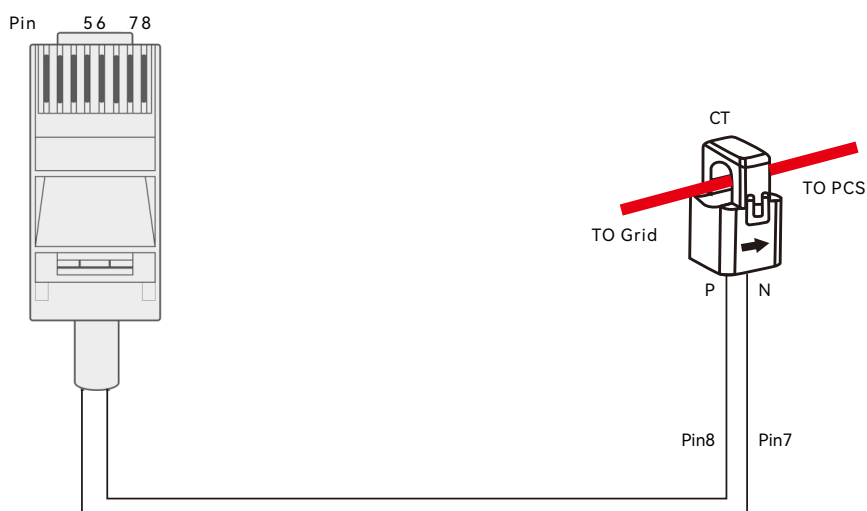

Note: If the load power reading on the LCD is incorrect, check the CT arrow direction. If needed, reverse the CT direction via the LCD settings.

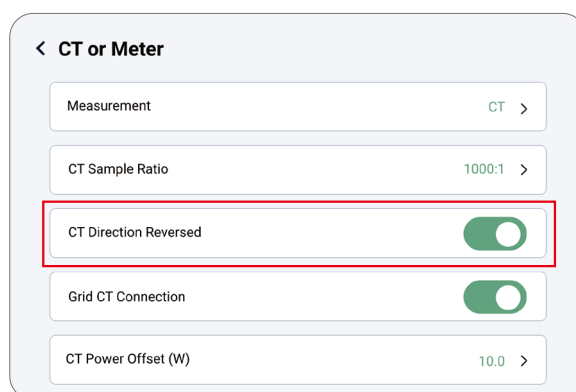

5.9.3 CT Clamp Ratio

The inverter supports three CT ratios: 1000:1, 2000:1, and 3000:1. The CT supplied with the inverter has a ratio of 1000:1.

If a third-party CT is used, ensure that its ratio matches one of the supported values. Select the corresponding CT ratio in the inverter settings via the monitoring platform or the LCD.

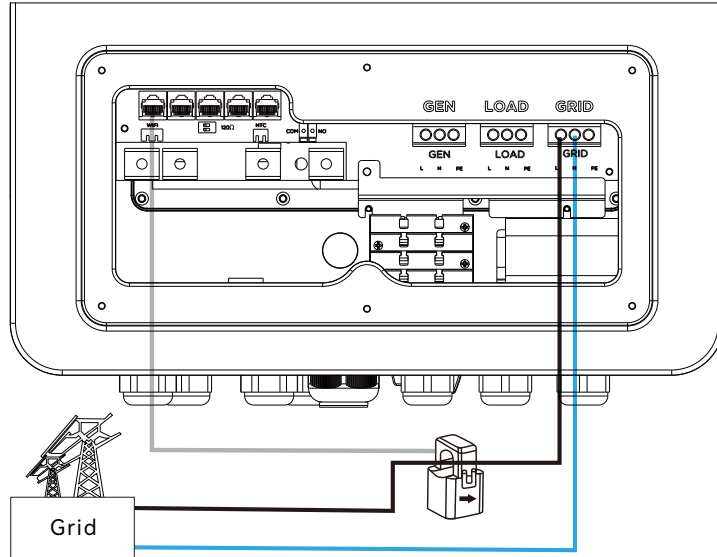

5.9.4 Meter Connection

Currently, only EASTRON Modbus-compatible meters are supported. If a meter is required for import/export detection instead of a CT, it must be connected to the inverter’s Meter 485A and 485B terminals. Please contact LuxpowerTek for detailed guidance.

LCD setting: Settings -> Grid Setting -> CT or Meter.

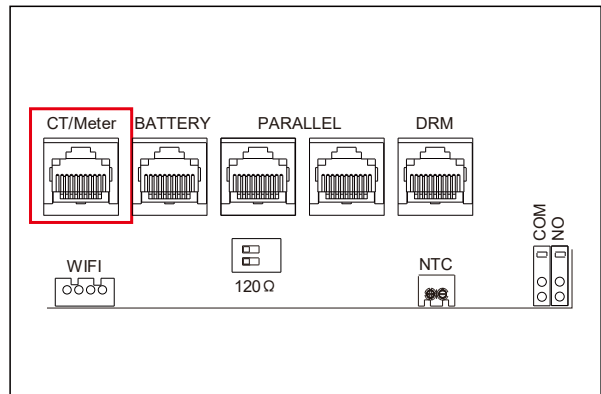
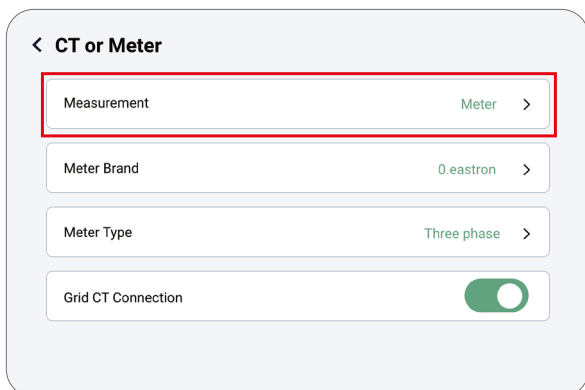

5.9.5 Safety Standard Configuration Guidance

- Go to the **Settings** menu and enter the **Advanced** interface to select the grid rule. Users can choose the appropriate grid rule according to their local grid regulations.

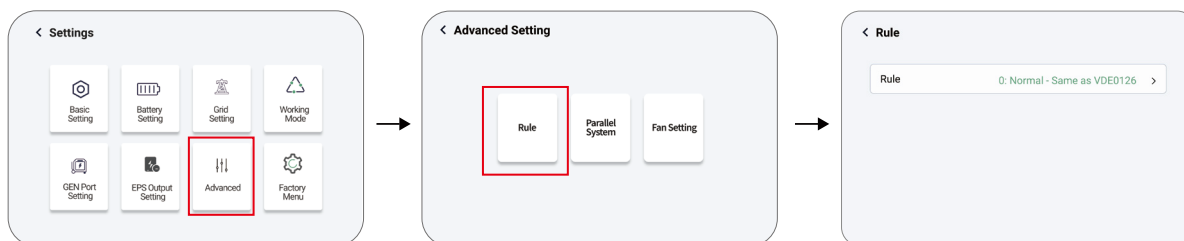

- A password is required when modifying the rule. The default password is **00000**. You can change the password in the monitoring settings.

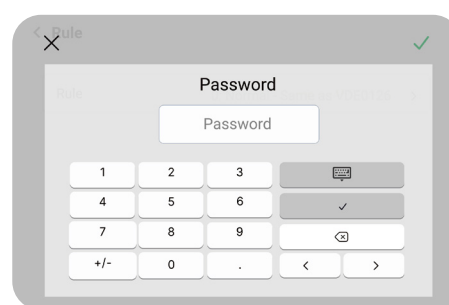

- Enter the correct password, and the system will display "Password OK!"

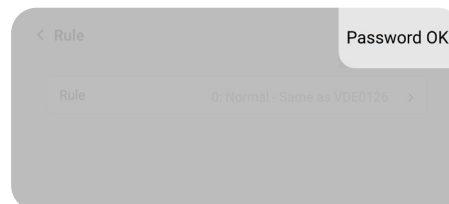

- Scroll up or down to select the appropriate safety standard (supported standards are listed in the table below), then tap ✓ in the upper right corner to confirm.

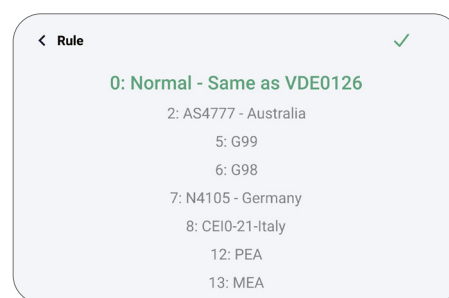

- When the "Set OK!" message appears, the configuration is complete. The inverter will automatically restart, and the selected safety standard will be applied after restart.

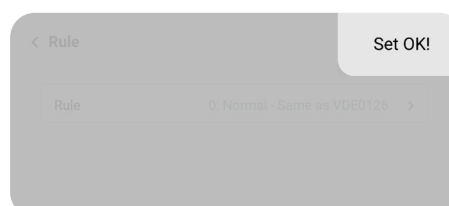

Safety Standard Details:

0	Normal - Same as VDE0126
2	AS4777 - Australia
5	G99
6	G98
7	N4105 - Gemmany
8	CEI0-21 - Italy
12	PEA
13	MEA
16	South Africa
18	CEI021ARETI
19	EN50549-10
21	PTPiREE (Poland)

5.10 GEN Port Function

NOTICE

1. The GEN port is a multifunctional interface that can be configured for one of the following three application modes:

- a. Generator Connection
- b. Smart Load
- c. AC Coupling

These three functions are mutually exclusive. Only one function can be selected for actual use; they cannot be used simultaneously.

2. The generator must be connected to the GEN port through a dedicated circuit breaker to ensure safe operation. It is recommended to use a circuit breaker compliant with IEC 60947-1 / IEC 60947-2 standards, with a typical rating of 50A/2P. The breaker size may be adjusted according to the rated power of the generator.

5.10.1 Generator Connection

5.10.1.1 Generator System Connection

This inverter supports generator connection via the GEN port, enabling both battery charging and load supply.

In the event of a grid outage, the generator can serve as a backup power source to ensure continuous system operation.

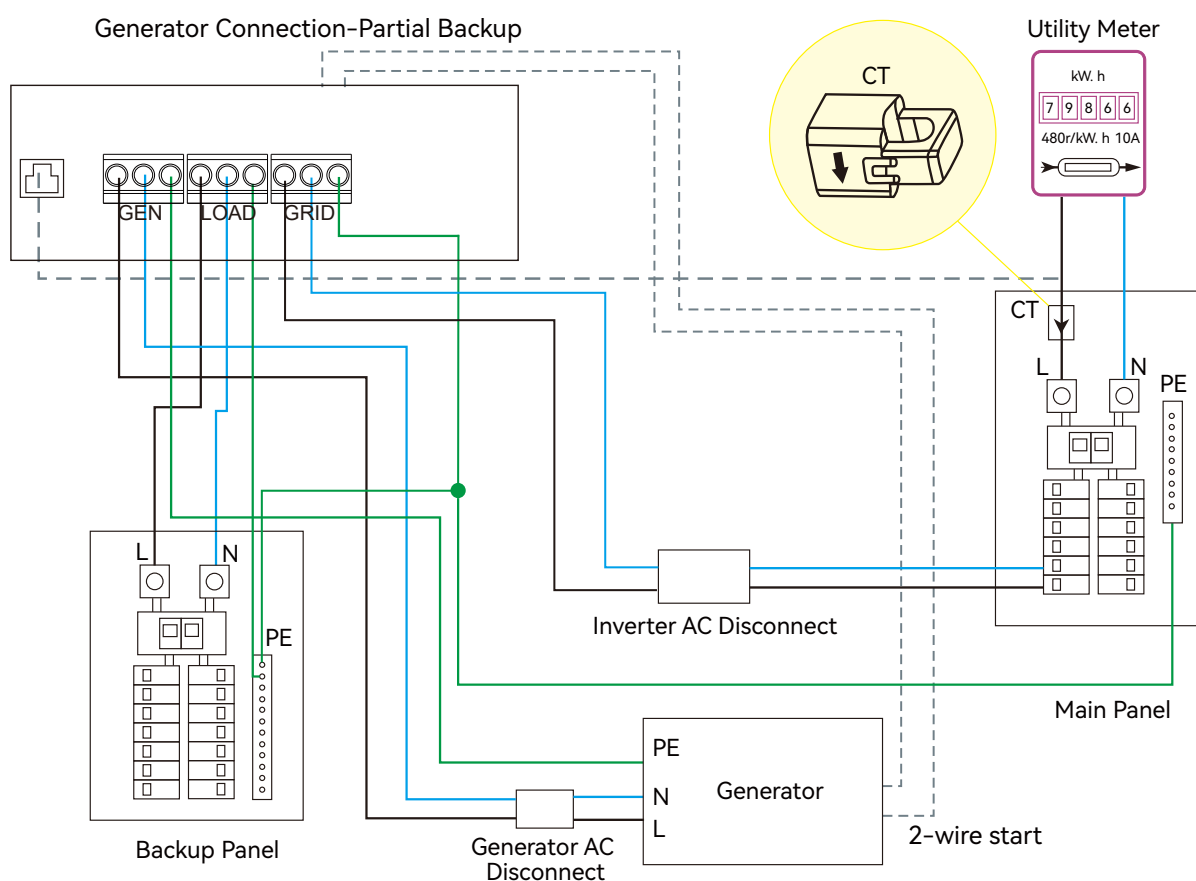

Generator Connection-Partial Backup

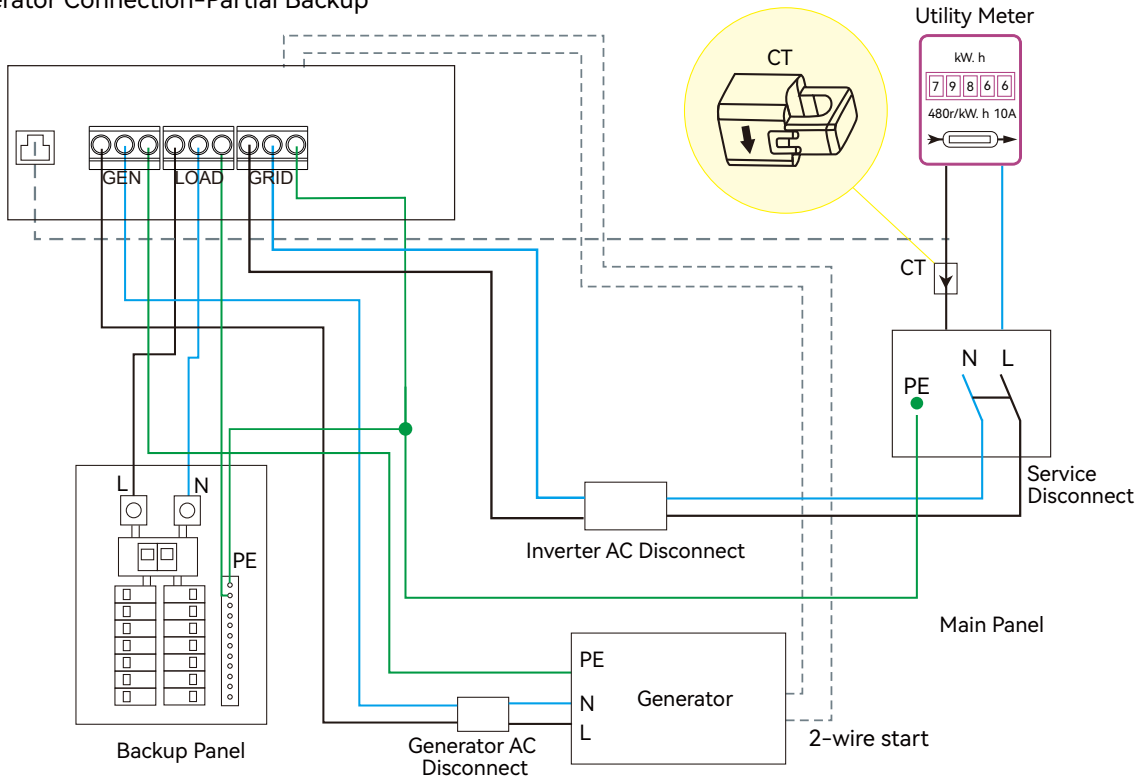

5.10.1.2 GEN Port Wiring

The maximum current of the generator port connector is 52A for the GEN3 series and 80A for the GEN PRO series. When starting the generator, please ensure that the total load current does not exceed the corresponding maximum current limit.

Wiring Procedures

Step 1: Before performing any wiring, ensure that the inverter (and all parallel inverters, if applicable) is completely powered off, the generator supply is disconnected, and all circuit breakers are in the OFF position to prevent equipment damage.

Step 2: Prepare the generator cables according to Steps 1–6 in Section 5.7.3, then connect the cables to the correct terminals accordingly.

Step 3: Verify that the wires are securely connected and cannot loosen.

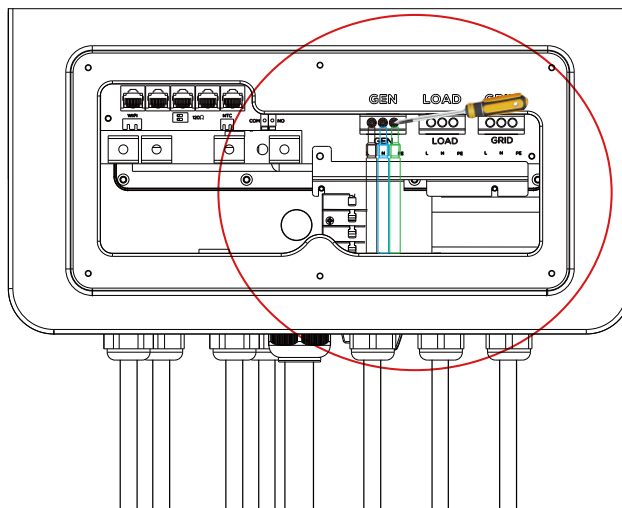

The generator start signal shall be connected to the COM board GEN Nominal Open (NO and COM), if users want to start generator remotely.

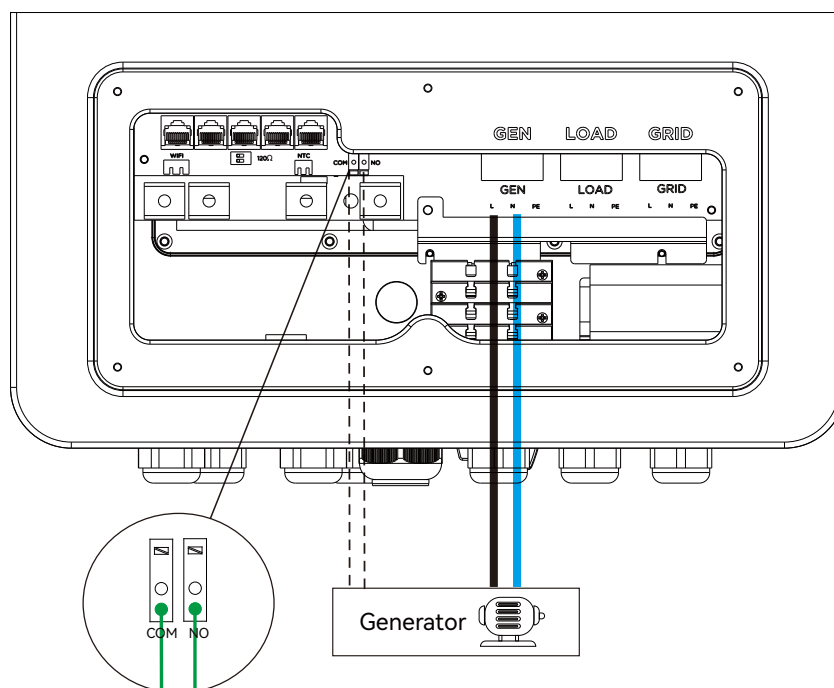

5.10.1.3 Gen Boost Function

When the generator is running, it supplies power to loads connected to the LOAD port.

If the generator power is insufficient, the GEN Boost function allows the PV system and battery to support the load together. This ensures stable operation and prevents generator overload.

When enabled, the system also reserves a power margin for the generator, reducing fluctuations and extending its lifespan.

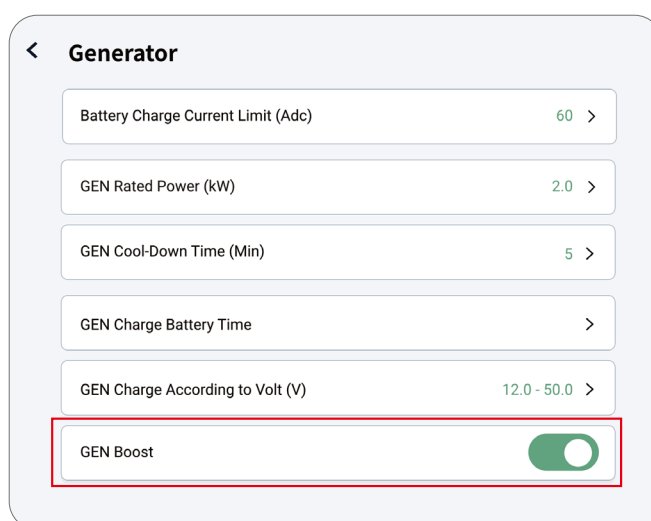

5.10.1.4 Generator Startup and Stop Settings

The generator control mode is determined by the battery charge control setting. The system uses either battery voltage or state of charge (SOC) based on the selected battery charge mode.

If the battery is configured for voltage-based control, the generator operates based on battery voltage.

If SOC-based control is selected, the generator operates based on SOC.

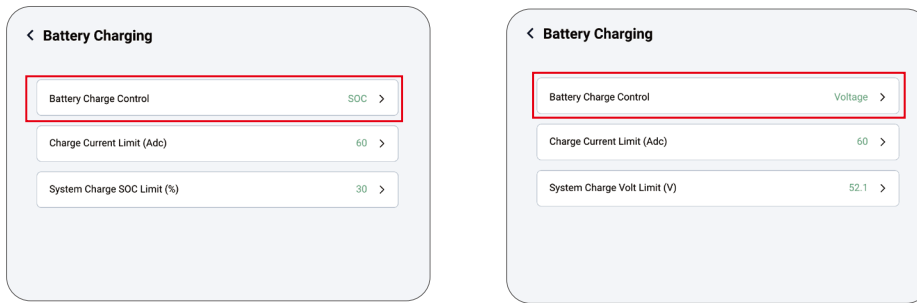

Configuration:

Users can configure the generator charging logic via the monitoring platform or the LCD interface:

- By Voltage and Time: Recommended for lead-acid batteries.
- By SOC and Time: Recommended for lithium-ion batteries.

Configurable parameters include:

- Generator start voltage or SOC
- Generator stop voltage or SOC
- Generator charging time (Time 1 and Time 2)
- Battery charge current limit
- Generator input power limit
- Generator cool-down time limit

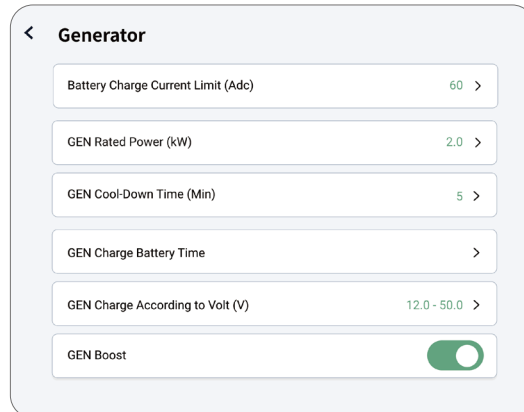

Start Conditions:

The generator will start when the grid is unavailable and any of the following conditions is met:

- Battery voltage or SOC falls below the configured start threshold.
- BMS issues a charge request.
- Battery voltage or SOC falls below the configured threshold within the scheduled charging period.
- A manual start command is issued via the monitoring platform.

Stop Conditions:

The generator will stop when any of the following conditions is met:

- Battery voltage or SOC reaches the configured stop threshold.
- The configured charging time period has ended.
- Charging completion condition is reached.
- In manual start mode, the generator will automatically stop after a 20-minute exercise run.

5.10.2 Smart Load

5.10.2.1 Function Overview

The Smart Load function automatically activates designated loads (such as water heaters or EV chargers) when battery energy is sufficient and PV generation is available.

When battery energy is low or PV generation decreases, the system automatically disconnects the Smart Load to prioritize power supply to essential household loads.

5.10.2.2 Wiring Instructions

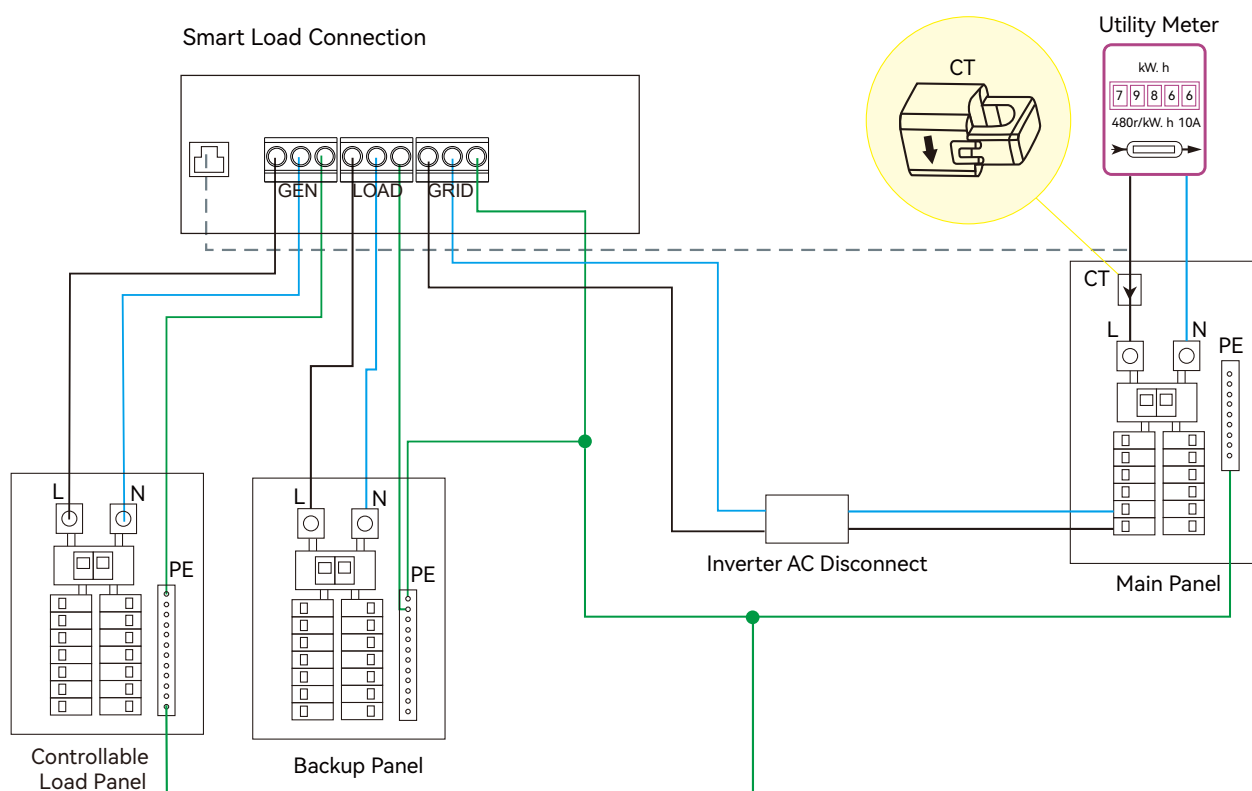

Wiring Procedure

Step 1: Ensure that the inverter and all connected loads are powered off, and all circuit breakers are in the OFF position.

Step 2: Identify and connect the Smart Load wiring according to local electrical standards.

In IEC systems:

- L (Live): Brown or black
- N (Neutral): Blue
- PE (Ground): Yellow/green

Step 3: Connect the Smart Load L and N conductors to the corresponding L and N terminals of the GEN port. Connect the PE conductor to the inverter grounding terminal.

5.10.2.3 Smart Load Settings

Enable smart load

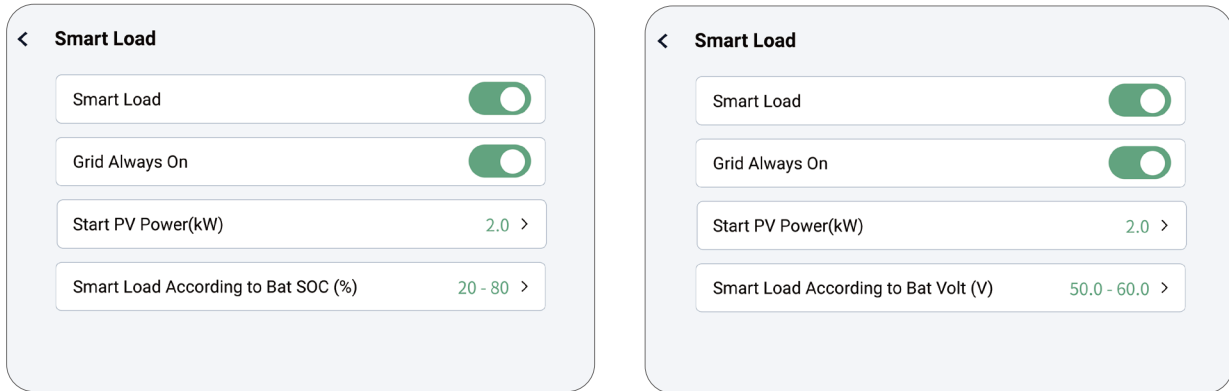

Enable “Grid always on”: When connected to the grid, the smart load remains continuously connected.

Start PV Power: Input the PV power threshold at which you want the smart load to start. You can also input the battery's SOC or voltage to select when to start and stop.

If your home already has an existing grid-tied system, you can connect it to our Smart Load port as an AC power input, transforming your grid-tied system into an energy storage system.

5.10.2.4 Example Applications

- Automatically start a water heater when PV generation is sufficient.
- Enable EV charging after the battery is fully charged.
- Run high-power household appliances during off-peak periods using remaining energy.

5.10.3 AC Coupling

5.10.3.1 Function Overview

The AC Coupling function allows users to integrate an existing on-grid inverter system through the GEN interface, thereby upgrading the system into a hybrid energy storage system.

- When the utility grid is disconnected, this inverter automatically switches to off-grid mode, maintaining stable system voltage and frequency, and enables the on-grid inverter to continue generating power via the GEN interface.
 - When PV power is sufficient, the inverter prioritizes load supply and uses surplus energy to charge the battery.
 - Once the battery is fully charged, the inverter will limit the output power of the on-grid inverter.
 - When PV power is insufficient, both the battery and the on-grid inverter will supply power jointly to ensure uninterrupted operation of critical loads.
- When the utility grid is available, this inverter and the on-grid inverter operate in coordination. Solar energy can simultaneously power loads and charge the battery. When load demand is low or the battery is fully charged, excess energy can be exported to the grid, ensuring optimal energy utilization.

NOTICE

When using AC Coupling, ensure that the system has grid-connection approval and complies with local grid regulations.

5.10.3.2 Wiring Instructions

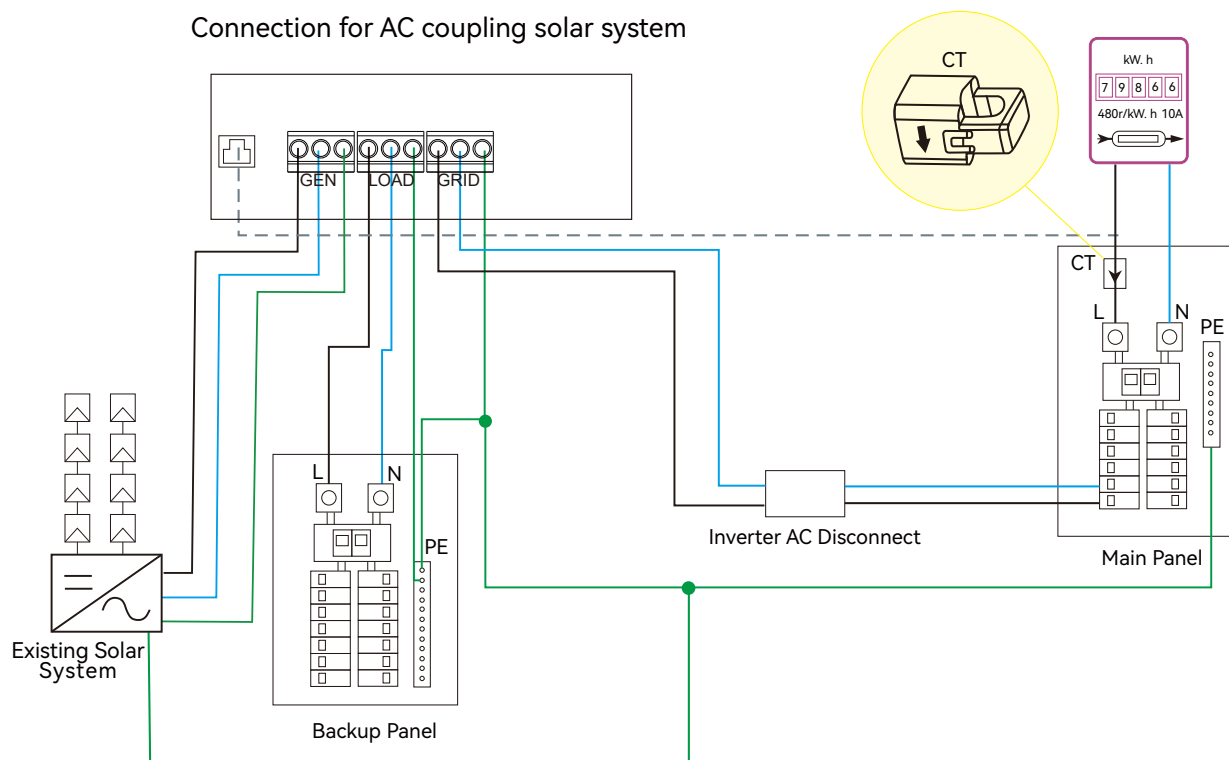

Wiring Procedure

Step 1: Ensure that the inverter, the grid-tied inverter, and the grid are powered off, and all circuit breakers are in the OFF position.

Step 2: Connect the output terminals of the grid-tied inverter (L, N, PE) to the corresponding terminals of the GEN port.

In IEC systems:

L (Live): Brown or black

N (Neutral): Blue

PE (Ground): Yellow/green

Step 3: It is recommended to install a dedicated circuit breaker in the AC coupling circuit to ensure safe operation.

5.10.3.3 AC Coupling Settings

Enable AC Coupling on LCD

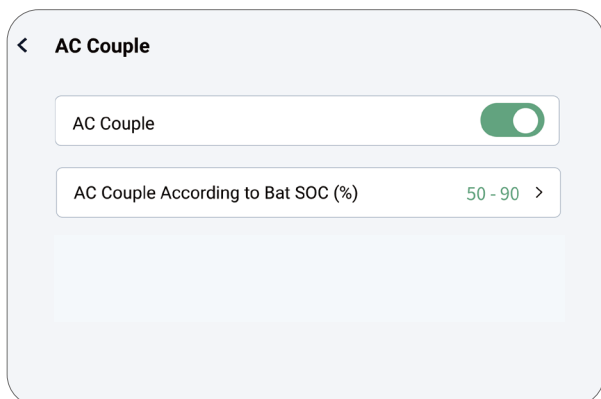

When the battery SOC reaches the configured AC Coupling Start Threshold, the grid-tied inverter will start operating. Its output power can be used to charge the battery or supply loads.

When the battery SOC falls to the configured AC Coupling Stop Threshold, the grid-tied inverter will stop operating to prevent battery over-discharge.

Configuration Requirements:

Enable the AC coupling function when connecting an existing grid-tied inverter to the GEN port.

Parameter Description:

Start SOC (%): The SOC at which the AC-coupled inverter starts operating in off-grid mode (50%–70% recommended).

End SOC (%): The SOC at which the AC-coupled inverter stops operating in off-grid mode (90% recommended).

Grid Interaction Behavior:

When grid-connected mode and Grid Sell Back are enabled, the grid-tied inverter will remain active and export excess power to the grid. Ensure that grid export is permitted by your local utility.

When Grid Sell Back is disabled, the grid-tied inverter will not export power to the grid.

5.11 Parallel Connection

The hybrid inverter supports parallel connection, allowing system power and energy capacity to be expanded for different application scenarios. For the GEN3-LB-EU 3–8K and GEN PRO-LB-EU 8–12K models, up to 16 units can be connected in parallel to expand the overall system capacity, as shown in the wiring diagram below. By default, the manual bypass switch connects essential loads to the LOAD panel; in the event of an inverter failure, the loads can be switched to the utility supply to ensure continuous power availability.

5.11.1 Single-phase Parallel System

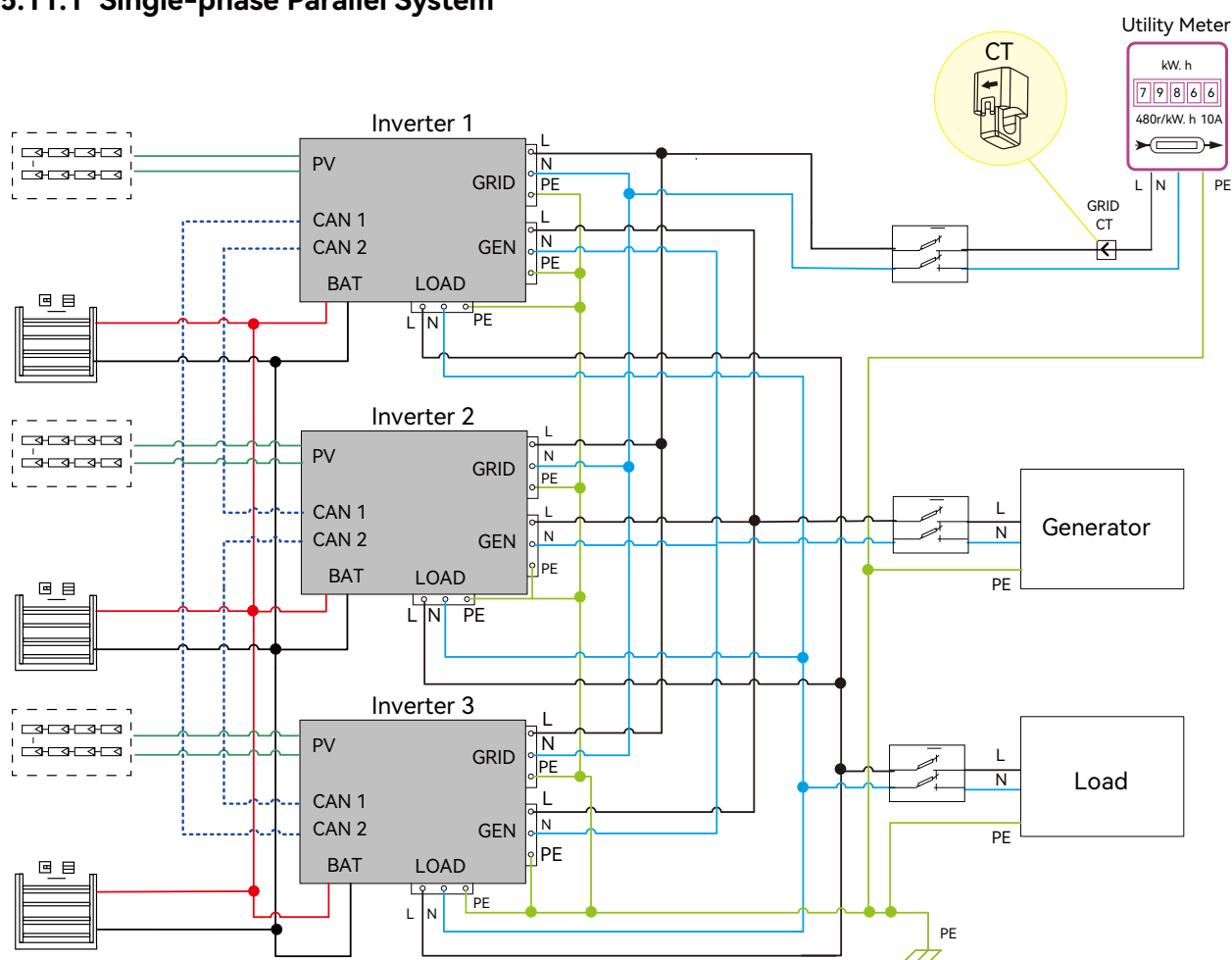

Inv1 setting

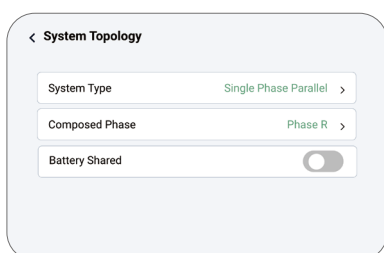

Inv2 setting

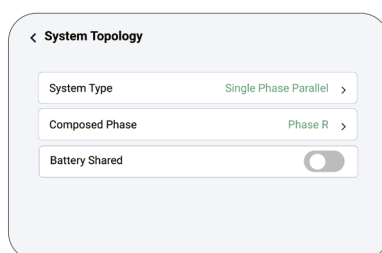

Inv3 setting

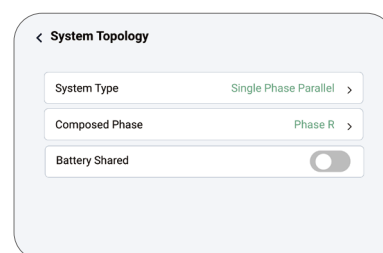

5.11.2 Three Phase Parallel System

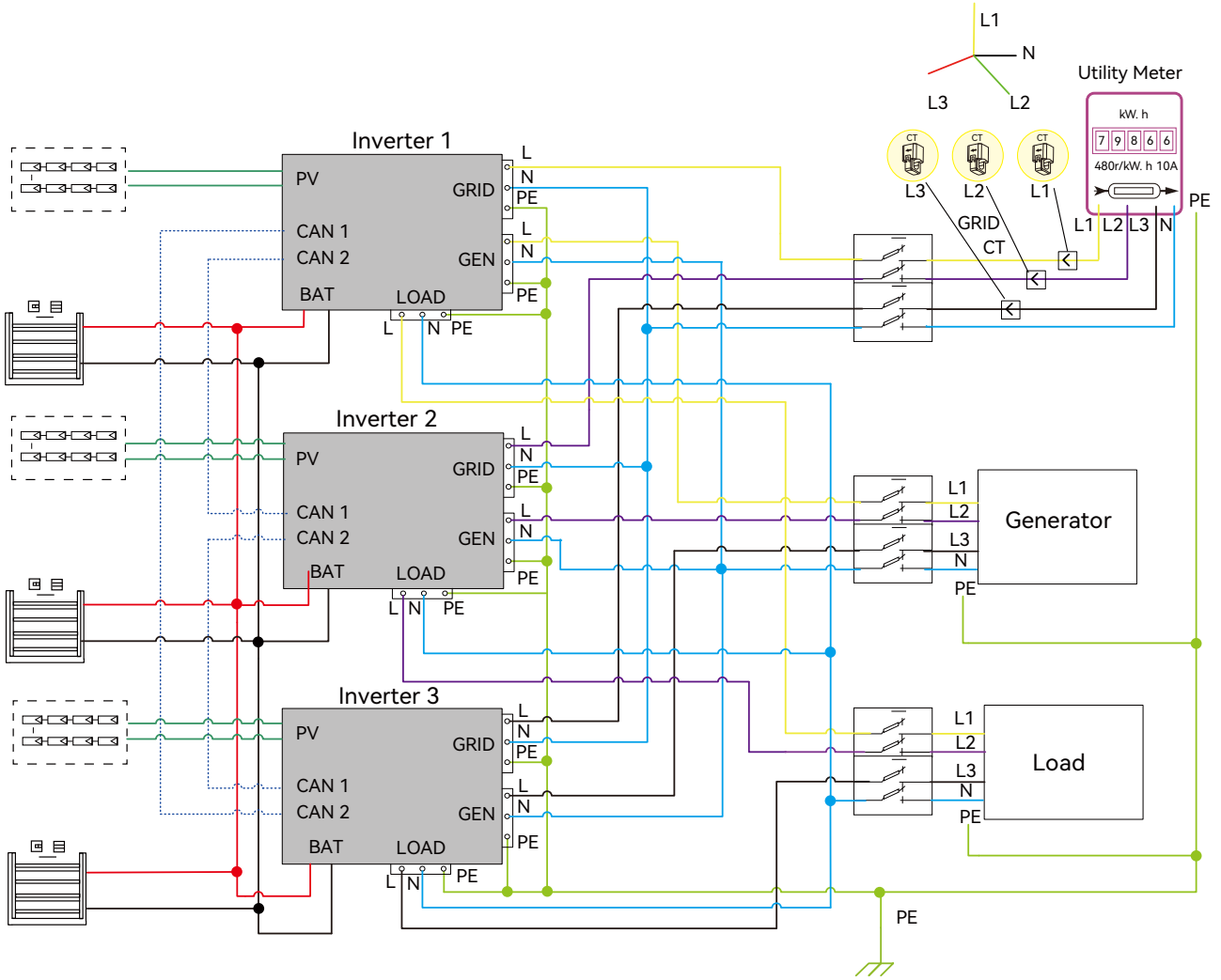

Inv1 setting

< System Topology

System Type Three Phase Parallel >

Composed Phase Phase R >

Battery Shared

Inv2 setting

< System Topology

System Type Three Phase Parallel >

Composed Phase Phase S >

Battery Shared

Inv3 setting

< System Topology

System Type Three Phase Parallel >

Composed Phase Phase T >

Battery Shared

5.11.3 DIP Switch Settings

Set the CAN DIP switches according to the inverter position.

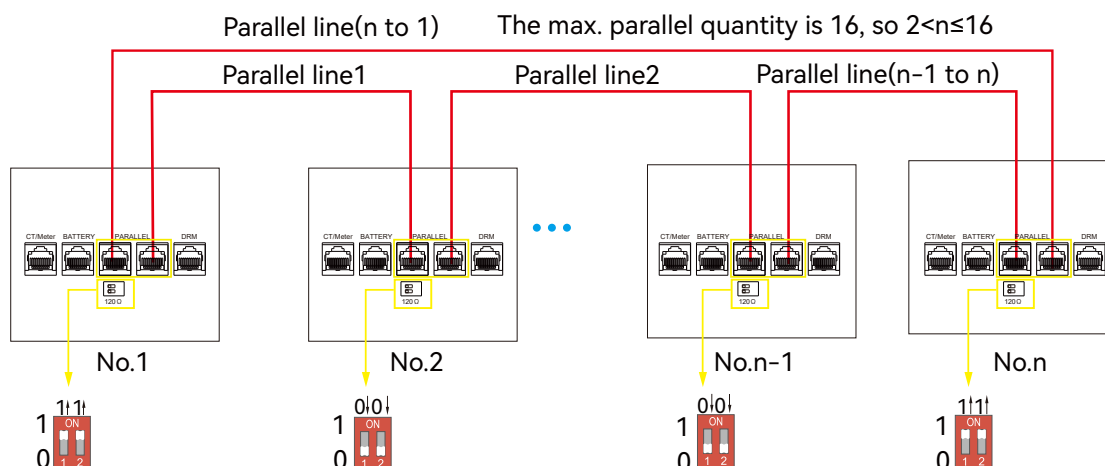

If the communication cable is not long enough, use a straight-through (pin-to-pin) cable.

5.11.4 Monitoring Settings

1. Set up system monitoring and add all dongles to the same station. Log in to the monitoring platform and go to: Configuration → Station → Station Management → Add Dongle.

Plant name	Installer	End User	Country	Timezone	Daylight saving time	Create date	Action
1 Genesis		Aspergo install	South Africa	GMT+2	No	2019-03-14	Station Management
2 Butler Home	Elangeni	johnbutler	South Africa	GMT+2	No	2019-03-25	Station Management
3 Office			South Africa	GMT+2	No	2019-06-03	Station Management
4 Cronje Home	Broomhead	cronje	South Africa	GMT+2	No	2019-07-16	Station Management

2. If the system uses a shared battery bank, enable the Shared Battery function. Otherwise, keep it disabled.

3. Configure the system as a parallel group in the monitoring platform.

Serial number	Status	Solar Power	Charge Power	Discharge Power	Load	Solar Yield	Battery Dischar	Feed Energy	ConsumptionEr	Station name	Parallel	Action
1 0272011008	Normal	228 W	42 W	0 W	182 W	215.3 kWh	39.6 kWh	0 kWh	551.2 kWh	Dragonview	A-1	Parallel
2 0272011011		35 W	32 W	0 W	0 W	158.7 kWh	21.1 kWh	0 kWh	160.5 kWh	Dragonview	A-2	Parallel
3 0272011012		1 kW	129 W	0 W	1 kW	170.3 kWh	49.9 kWh	0 kWh	434.5 kWh	Dragonview	A-3	Parallel
4 0272011017		79 W	48 W	0 W	106 W	99 kWh	85.6 kWh	0 kWh	257.1 kWh	Dragonview	A-4	Parallel

For more detailed guidance, please contact your inverter supplier.

NOTICE

Notices for parallel system:

- A. Ensure the generator is connected to all inverters in the parallel system (if applicable).
- B. If PV panels cannot be evenly distributed among all inverters, it is recommended to connect more PV panels to the primary inverter.
- C. The values displayed on each inverter LCD represent individual inverter output, not the total system output.

5.12 Monitor System Setup

5.12.1 Wifi/GPRS/4G/WLAN Dongle Connection

Use a WiFi, WLAN, 4G, or GPRS dongle to monitor the inverter remotely.

Monitoring data can be accessed via a computer or smartphone.

To view data on a smartphone, download the app from Google Play or the Apple App Store, then log in with your account.

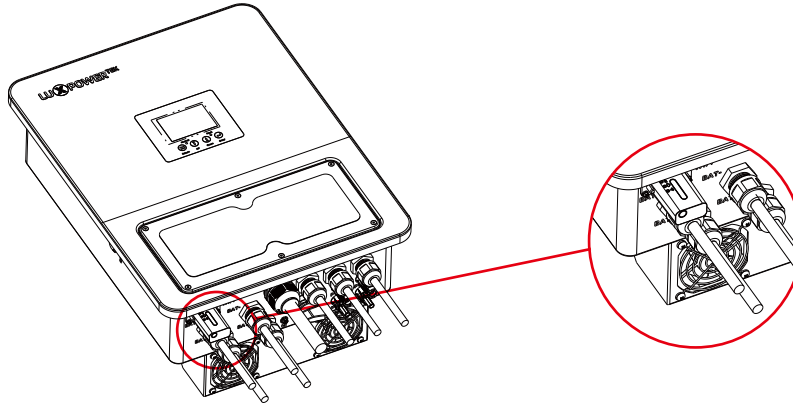

5.12.2 Setup the Monitor System

1. Create an Account

Account creation depends on the user role:

Installer/Sub-distributor: Please obtain your account credentials from your upstream supplier.

End User: You can register via the mobile app using an Installer Code provided by your supplier.

Alternatively, your supplier can share a registration link for account creation.

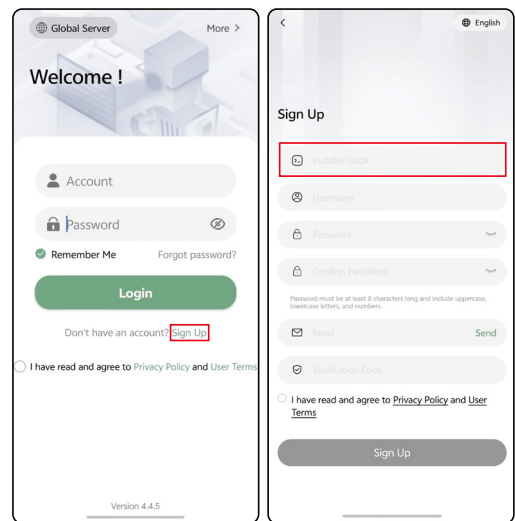

2. Create a Station and Add Dongle

After logging in, create a station first. Then add the WiFi dongle to the created station.

If multiple stations are required, you can create additional stations as needed.

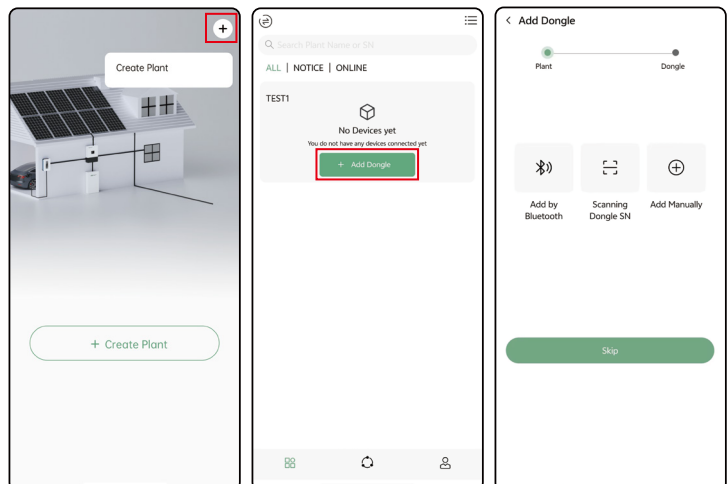

5.12.3 Set Home WiFi Password for Dongle

Setup Procedure

Step 1. Connect your mobile phone to the “DGxxxxxxx” WiFi network (“DGxxxxxxx” is the serial number of the WiFi dongle).

Step 2. Open the app and tap “Dongle Connect”.

Step 3. Select the home WiFi network and enter the password. Tap “Home WiFi Connect”. The dongle will restart automatically and connect to the server.

Step 4. Check the LED indicators on the WiFi dongle. The middle LED will remain steady when the connection is successful.

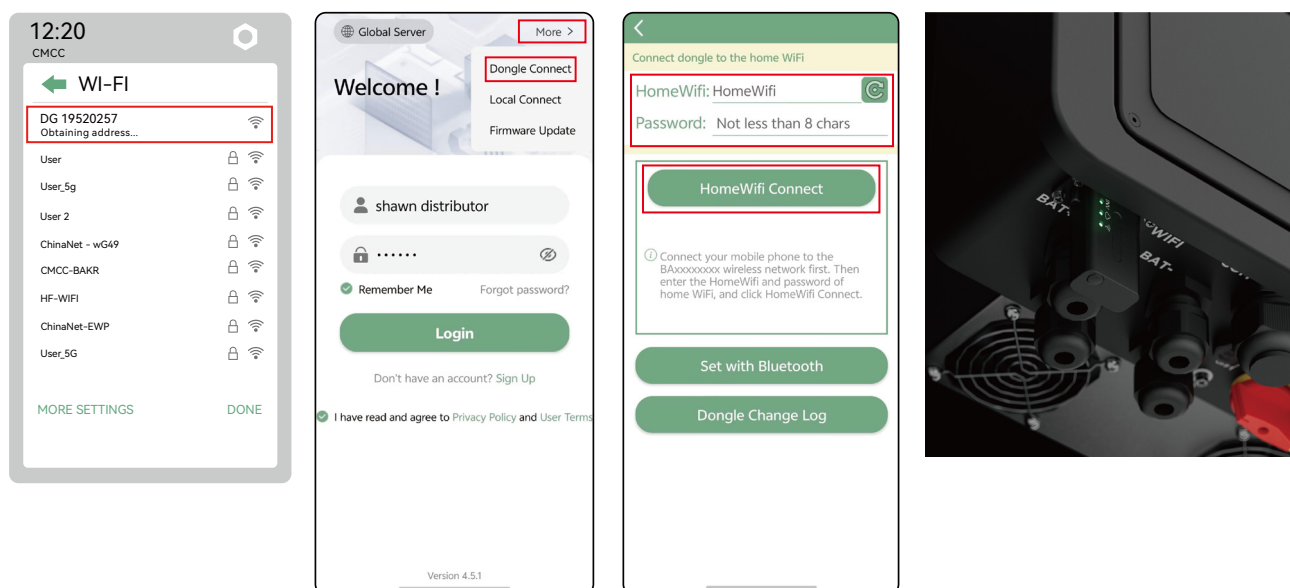

Step 5. Disconnect from the “DGxxxxxxx” network and log in to the app. The inverter will appear online, and remote monitoring will be available.

Additional Information

For more details on WiFi dongle setup and monitoring system configuration, refer to:

1. Wifi Quick Guidance
 - Quick setup guide for connecting the WiFi dongle to a local network (also included in the product packaging).
2. Monitoring System Guide
 - Includes account registration, parameter settings, and system configuration.
3. Monitoring UI Guide
 - Overview of the monitoring interface.

5.12.4 4G Dongle Monitoring Setup

Register an account as described in Section 5.12.2 before setup. Insert a SIM card into the 4G dongle, then plug the dongle into the inverter. After approximately 5 minutes, the inverter will appear online in the monitoring platform.

5.12.5 Third Party RS485 Communication

The INV485 interface is shared with the WiFi module. When the WiFi module is not in use, this interface can be used for third-party RS485 communication.

For protocol details, please contact your device supplier

Pin	Description
1	Meter RS485 B
2	Meter RS485 A
3	INV RS485 B
4	INV RS485 A
5	CT N
6	CT P
7	CT N
8	CT P

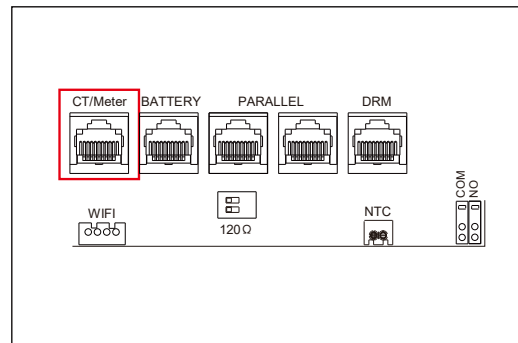

6. Operation Guide

6.1 Working Mode

6.1.1 Working Mode Overview

Description

The system supports multiple operating modes, which can be configured in combination based on time periods. Different modes can take effect during different time periods; when time periods overlap, the higher-priority mode will override the lower-priority one.

The “Active Mode” displayed on the interface indicates the currently effective operating mode. When none of the modes are active, the system will default to Self Consumption mode.

System Operation Logic

The system does not operate under a single mode; instead, it follows a mechanism based on time scheduling and priority override.

- Different modes can be configured to run during different time periods.
- Multiple modes can be active at the same time.
- Higher-priority modes will override lower-priority modes.

Mode Priority Description

When multiple modes are active during the same time period, the higher-priority mode will override the lower-priority ones.

The greyed-out areas on the interface indicate that the corresponding mode is overridden.

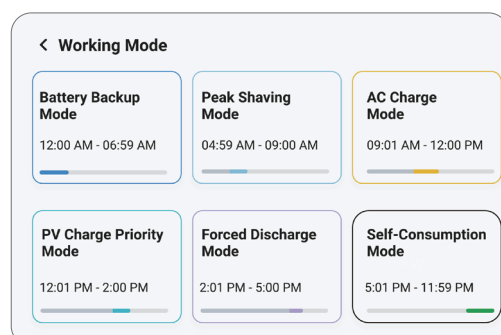

6.1.2 Self-Consumption Mode (Default)

Self Consumption Mode is the default operating mode, designed to optimize daily energy usage.

- **Operation Logic**
 - PV supplies the load first.
 - Surplus PV charges the battery.
 - Excess energy is exported to the grid (if enabled).
- **Load Supply Priority**
 - PV → Load.
 - Battery → Load (when PV is insufficient).
 - Grid → Load (when PV and battery are insufficient).
- **Application Scenarios**
 - Suitable for daily residential use, maximizing solar self-consumption and reducing electricity costs.
- **Related Notes**
 - If no other modes are active, the system automatically operates in this mode.
- **Example**

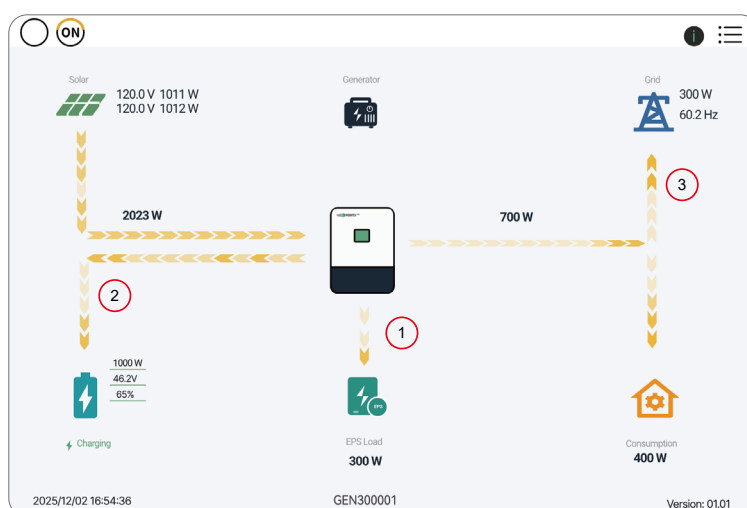

When PV power is sufficient, it supplies the load first, then charges the battery, and finally exports excess energy to the grid (if enabled).



When PV power is insufficient, PV and the battery supply the load together. If the battery is depleted, the grid supplies the load.

6.1.3 Backup Mode

Backup Mode prioritizes maintaining battery capacity to ensure power availability during grid outages. It operates continuously (24/7) and has the highest priority among all modes.

➤ **Related Settings**

Backup SOC, Backup Voltage, AC Charge Power.

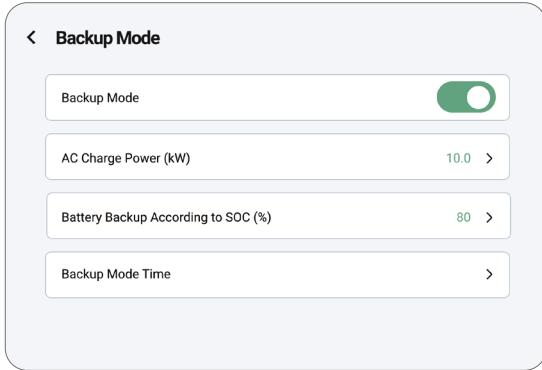

➤ **Operation Logic**

- Solar power is prioritized to charge the battery.
- When PV power is insufficient, the battery can be charged from the grid.
- The battery is maintained within the configured SOC or voltage range.

➤ **Application Scenarios**

Suitable for applications requiring high power reliability or backup readiness during grid outages.

➤ **Example**



During normal operation, PV power is used to charge the battery. If PV is insufficient, the grid supplements power and charges the battery.



During grid outages, the battery supplies the load to ensure uninterrupted power.

*** Note: If this working mode is not visible on your current LCD interface, please contact your device provider for the latest information.**

6.1.4 Peak Shaving Mode

Peak Shaving Mode limits the power drawn from the grid to reduce peak demand and electricity costs.

➤ Related Settings

Grid Peak-Shaving Power, Start Peak-Shaving Voltage/SOC, Time Period (T1/T2).

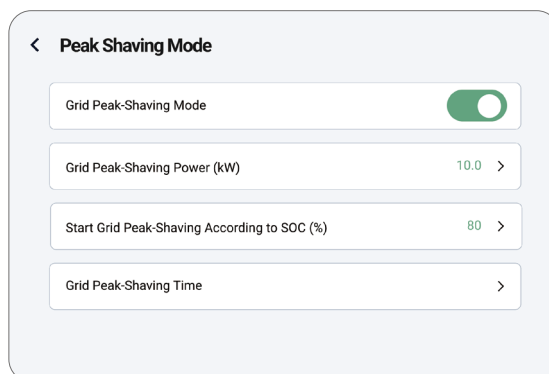

➤ Operation Logic

- Grid power is limited to the configured threshold.
- When load demand exceeds this limit, the battery supplies the excess power.
- Grid power consumption is kept within the set limit.

➤ Load Supply Priority

Grid → supplies the load within the set limit.

Battery → supplies the excess load when demand exceeds the limit.

➤ Application Scenarios

Suitable for regions with high peak electricity tariffs or demand charges.

➤ Example



When load demand exceeds the configured grid power limit, the battery discharges to supply the excess load, while the grid supplies power within the set limit.

*** Note: If this working mode is not visible on your current LCD interface, please contact your device provider for the latest information.**

6.1.5 AC Charge Mode

AC Charge Mode allows the battery to be charged using grid or generator power during defined time periods or under specific conditions.

➤ **Related Settings**

AC Charge Power, Start Voltage/SOC, End Voltage/SOC, Time period(T1/T2/T3).

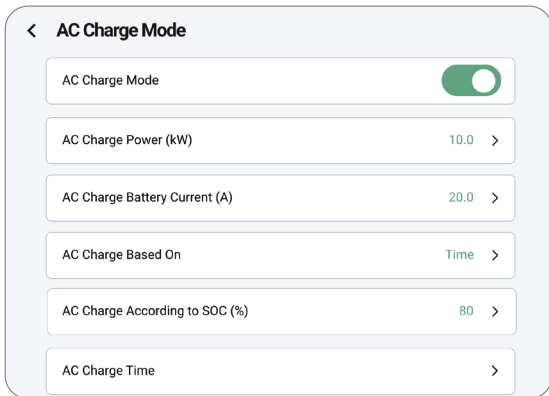

➤ **Operation Logic**

- The battery is charged using AC power (grid or generator).
- Charging is activated when the configured time period and SOC/voltage conditions are met.
- When the battery charging power demand exceeds the configured AC charge power limit, the battery can be charged from the PV power.

➤ **Load Supply Priority**

- Grid → supplies the load and charges the battery.
- PV → charges the battery when the AC charge power limit is exceeded.
- Battery → does not discharge during AC charging.

➤ **Application Scenarios**

Suitable for charging during off-peak electricity periods or for energy storage at night.

➤ **Example**

AC Charge:

During the configured time period, the grid charges the battery while supplying the load. The battery remains in a charging state and does not discharge.



PV&AC Charge:

When the power of battery charging and load consumption exceeds the configured limit, PV power can be used for supplemental supply, while the battery remains in a charging state and does not discharge.

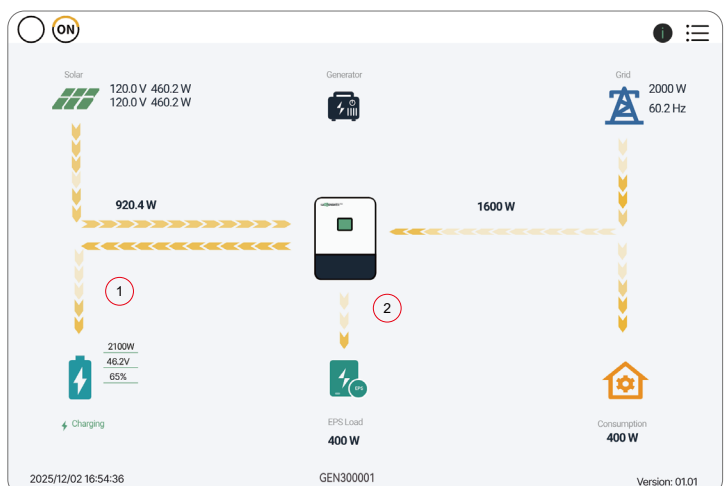

6.1.6 PV Charge Priority Mode

PV Charge Priority Mode prioritizes using PV power to charge the battery.

➤ Related Settings

Charge First Power, Start Voltage/SOC, Time Period (T1/T2/T3).

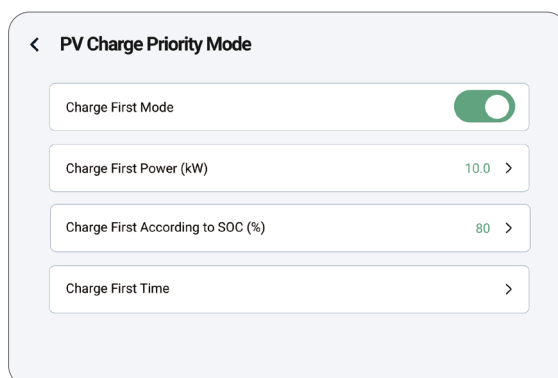

➤ Operation Logic

- PV power is used to charge the battery first.
- After the battery charging demand is met, PV power supplies the load.
- Excess PV power can be exported to the grid (if enabled)

➤ Load Supply Priority

PV → Battery (priority).

PV → Load (after charging demand is met).

Grid → supplies the load when PV is insufficient .

➤ Application Scenarios

Suitable for scenarios where battery charging is prioritized or where maximum PV utilization is required.

➤ Example



PV power is first used to charge the battery. Once the battery charging requirement is met, PV power supplies the load, and any excess energy can be exported to the grid (if enabled).

6.1.7 Forced Discharge Mode/Export PV Only Mode

Forced Discharge Mode

Forced Discharge Mode forces the battery to discharge at a defined power level during specified time periods.

➤ **Related Settings**

Forced Discharge Power, Stop Voltage/SOC, Time period(T1/T2/T3).

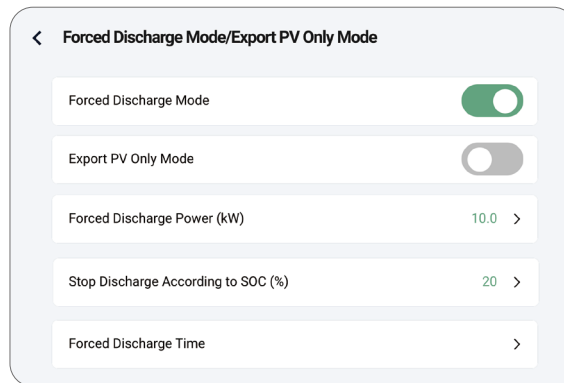

➤ **Operation Logic**

- The battery discharges at the configured power level.
- Discharging stops when the SOC or voltage reaches the set limit.
- Discharged power supplies the load first, and excess energy can be exported to the grid (if enabled).

➤ **Load Supply Priority**

- Battery → supplies the load (forced discharge).
- PV → supports the load when available.
- Grid → supplements or receives excess power as needed.

➤ **Application Scenarios**

Suitable for high electricity price periods or when battery capacity needs to be reduced for later charging.

➤ **Example**



During the configured time period, the battery discharges at the set power level to supply the load. If discharge power exceeds load demand, excess energy can be exported to the grid (if enabled).

Export PV Only Mode

Export PV Only Mode prioritizes exporting PV power to the grid (requires Grid Sell Back enabled).

➤ Related Settings

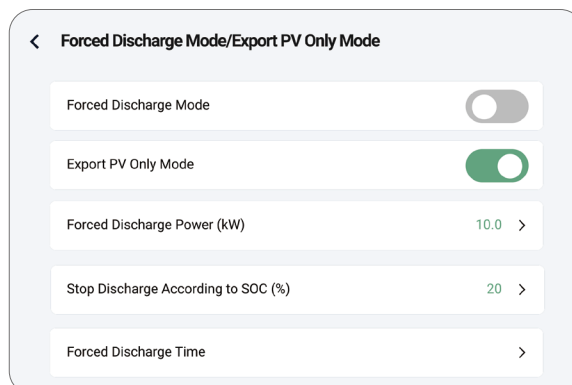

➤ Operation Logic

- PV power is exported to the grid as much as possible.
- PV power supplies the load when required.
- The battery only discharges when needed to support the load.

➤ Load Supply Priority

PV → Grid (priority).

PV → Load (when required).

Battery → supports the load when necessary.

Grid → supplies the load when PV and battery are insufficient.

➤ Application Scenarios

Suitable for maximizing PV export while preserving battery capacity.

➤ Example

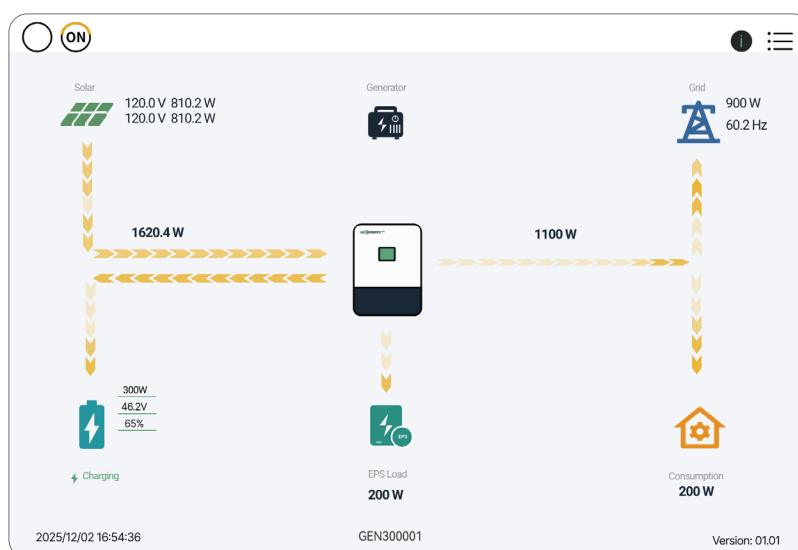

PV power is primarily exported to the grid. The battery remains reserved and only discharges when required to support the load.

*** Note: If this working mode is not visible on your current LCD interface, please contact your device provider for the latest information.**

6.2 LCD Display

6.2.1 Home Page

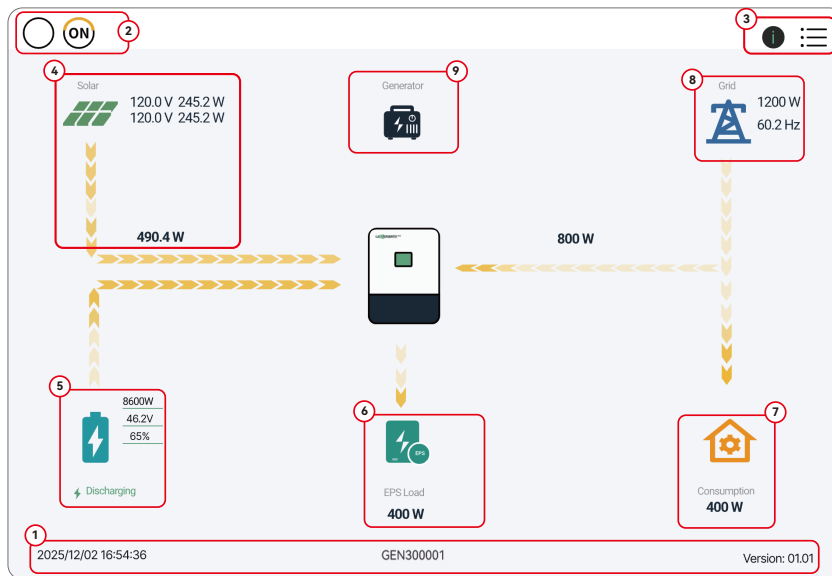

NO.	Description	Remarks
1	Generally information display area	Display the current time and date by default on the left (year/month/day/hour/minute, automatically switching), followed by the serial number, while the right side displays the firmware version information.
2	System operating status indicator (Left)	<ul style="list-style-type: none"> ● Gray: LCD not connected ● Green: LCD connected and no faults detected ● Red: Fault present in the unit ● Yellow: Warning present in the unit
	Screen Off (Right)	On the right side of this area, users can tap this icon to turn off the screen.
3	Help & Menu	View explanations of key terms for each section of the inverter energy storage system via the icon on the left. Tap the icon on the right to enter the menu page and set system parameters.
4	Solar inverter output power	Display the data of PV voltage and power.
5	Battery information and data	Display the voltage, SOC , input and output power.
6	LOAD output information and data	This area will display LOAD voltage, frequency, power.
7	Load consumption	Display the power consumption by the loads in on grid.
8	Grid information and data	Display the grid information of voltage, frequency, input or output power.
9	Generator information and data	Display the GEN information of voltage, frequency, input or output power. In on-grid mode, the GEN function cannot be enabled, and this area displays no data.

6.2.2 Quick Control

From the menu bar, select Quick Control to quickly enable the following functions:

- Start Quick Charge
- GEN Quick Start

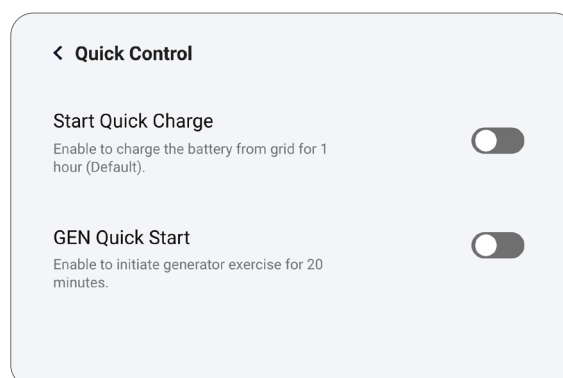
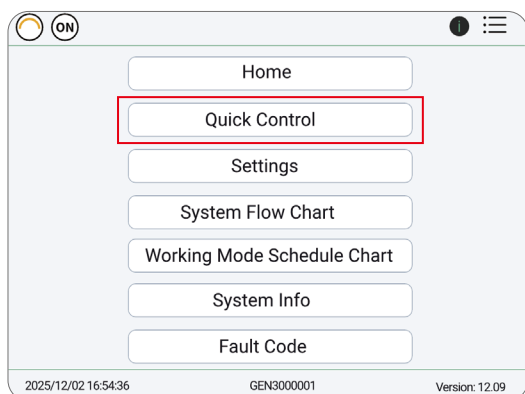

6.2.3 Setting Parameters

Select the Settings function in the menu, and you'll get into the main parameter setting page of the inverter.

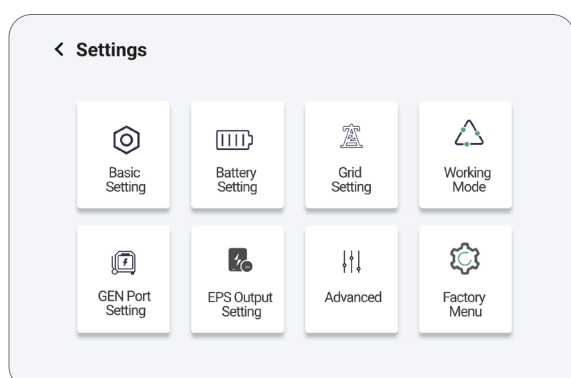

a). Basic Setting

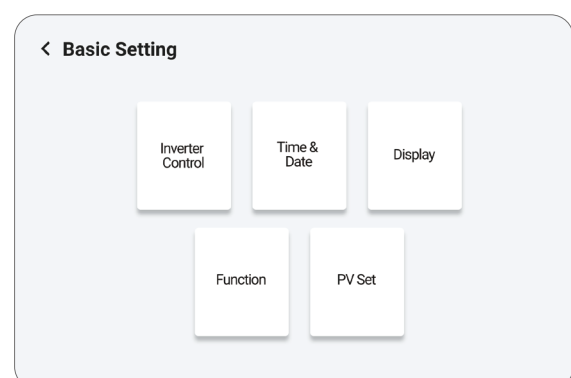

- **Inverter Control:** Used to configure inverter operating status, restart functions, and Modbus communication settings.
- **Time & Date:** Used to set the system date and time.
- **Display:** Used to configure display-related parameters, such as screen brightness, sleep time.
- **Function:** Used to configure grounding and neutral-related settings. Proper configuration should comply with local electrical regulations and installation requirements.
- **PV Set:** Configure the PV input operating mode, including DC source mode, parallel MPPT inputs, and independent MPPT inputs.

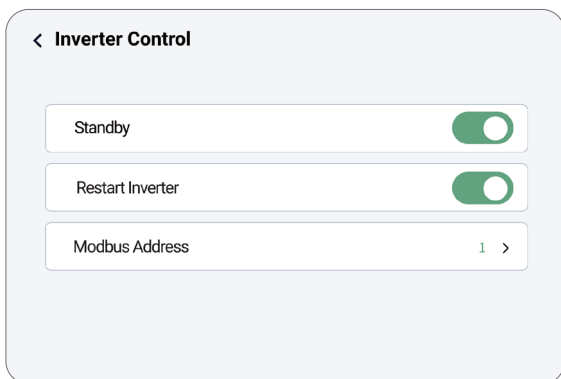

- **Normal/Standby:** Switch between operating and standby modes.
In Standby, all charging, discharging, and PV feed-in are disabled.
- **Restart Inverter:** Restart the system, please note the power maybe interrupted when restarted. You'll get into the parameter setting page of the inverter.

b). Battery Setting

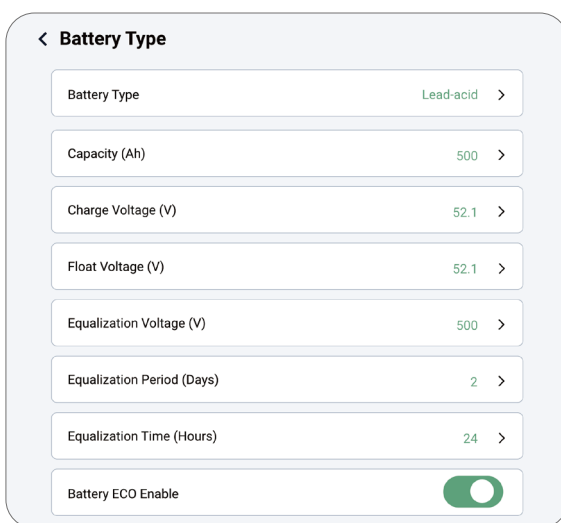

- **Battery Type:** No battery, lead-acid or lithium-ion. If lead-acid battery is selected, please input correct battery capacity. If lithium-ion battery is selected, please choose the battery brand in the lithium-ion brand drop down list.
- **Lead Acid:** When using lead-acid battery, you need to set parameters in these programs according to the battery manufacturer's recommendation.

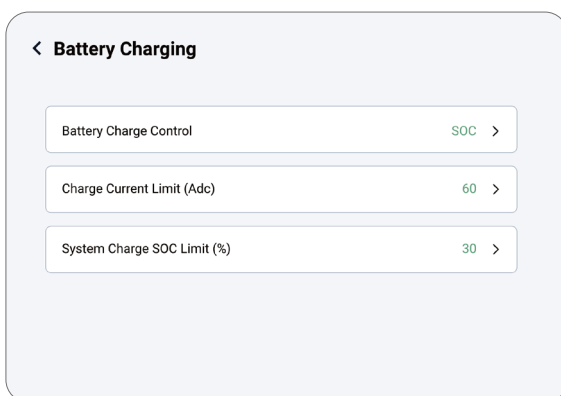

- **Battery Charge Control:** Users can decide to use SOC or Battery Voltage to control charge and discharge logic depending on battery type.
- **Charge Current Limit:** Users can set the maximum charge current (Max. 180A for GEN3-LB-EU 3-8K models; Max. 250A for GEN PRO-LB-EU 8-12K models).

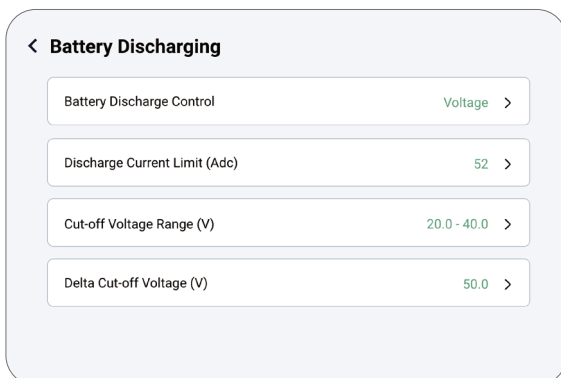

- **Battery Discharge Control:** You can choose "SOC" or "Voltage" to control the battery discharge state.
- **Discharge Current Limit:** Users can set the maximum discharge current.
- **On-grid Cut-off(%) and Off-grid Cut-off(%) / On-grid Cut-off(V) and Off-grid Cut-off(V):** End of discharge SOC/Cut of voltage in on-grid and of grid condition respectively.

c). Grid Setting

< **Export Control**

Grid Sell Back

Grid Sell Back Power (kW) 20.0 >

< **CT or Meter**

Measurement CT >

CT Sample Ratio 1000:1 >

CT Direction Reversed

Grid CT Connection

CT Power Offset (W) 10.0 >

< **Grid Connect**

AC Input Mode APL >

Connect Time (S) 30 >

Reconnect Time (S) 30 >

Grid Volt Connect Limit >

Grid Freq Connect Limit >

< **Grid Protection**

Voltage Protection APL >

Frequency Protection 30 >

Advanced Setting 30 >

- **Grid Sell Back:** Is for users to control whether solar power is exported to the grid. If exporting solar power is not allowed, users need to disable the “Grid Sell Back” option. If users' utility meter is tripped with even a little solar export, “Fast Zero export” can be enabled. Thus the export detection and adjustment will take place every 20ms, which will effectively avoid any solar power being exported. If export is allowed, users can enable “Grid Sell Back” and set a maximum allowable export limit in “Grid Sell Back Power”.
- **Measurement:** CT or Meter, default CT.
- **CT Direction Reversed:** If the CT are in a wrong direction which will cause the display to show incorrect information and features of the inverter will not function correctly, the installer can modify it by selecting it (only for direction not CT placement), there is no need to reconnect the CT and no need to go change it physically, in the order of loads--grid export--battery charging.
- **CT Power Offset:** Reduce the importing power or exporting power while working in on-grid mode.
- **Connect Time:** Set the countdown timer for on-grid.
- **Reconnect Time:** The inverter will attempt to reconnect to the grid after abnormal situations (i.e.voltage/frequency fluctuations) once this amount of time has elapsed.
- **Voltage Protection:** Configure the three-level grid overvoltage and undervoltage protection thresholds and corresponding protection time.
- **Frequency Protection:** Configure the three-level grid overfrequency and underfrequency protection thresholds and corresponding protection time.
- **Advanced Setting:** Configure Grid Soft Start, Power Soft Start Slope, and grid voltage moving average protection parameters.

d). Gen Port Setting

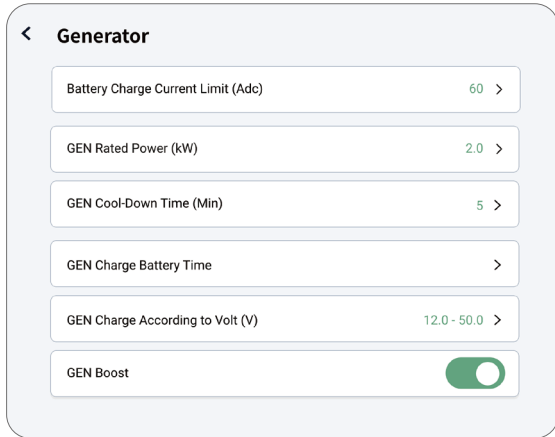

- **Battery charge current limit(A):** Set the Max. Battery charge current from the Generator. The Generator will start charging according to the charge start Volt/SOC, and stop charging when the battery voltage or SOC reaches the Charge end Volt/SOC value.
- **Gen rated power:** When the total power (load + battery charging) exceeds the set Gen rated power, the inverter will limit the battery charging power to prevent generator overload.

e). EPS Output Setting

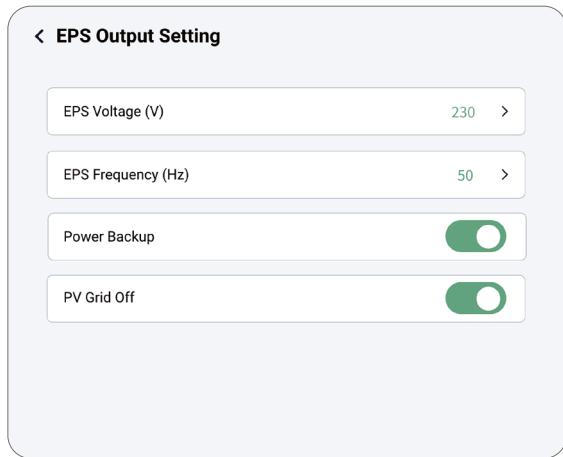

- **Power Backup:** Enables or disables backup power when the grid is lost. When enabled, the inverter supplies backup power to the load during grid outages. To ensure seamless transfer to backup power, enable "Seamless EPS switching." If no battery is installed, "PV Grid Off" can be enabled to allow the PV system to supply the load during grid failure or load-shedding.

f). Advanced

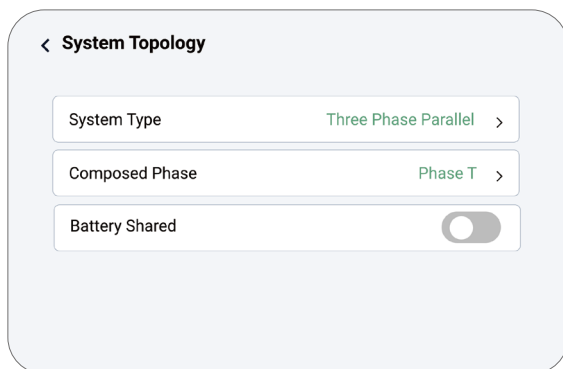

- **System Type:** Used to define the topology of the parallel system. Users can select single-phase or three-phase parallel mode according to the actual application scenario.
- **Composed Phase:** This is the phase code setting of the Load output. Once connected to the grid, the system will automatically detect the phase sequence of the inverter (consistent with the connected grid supply) and displays it accordingly.
- **Battery Shared:** When the inverter is connected as a parallel system, all inverters need to share the battery. Therefore, the "Share Battery" setting must be enabled on all inverters.

6.2.4 System Flow Chart

Select System Flow Chart from the menu to view real-time operating data for all system components, including the solar, grid, battery, and load sides.

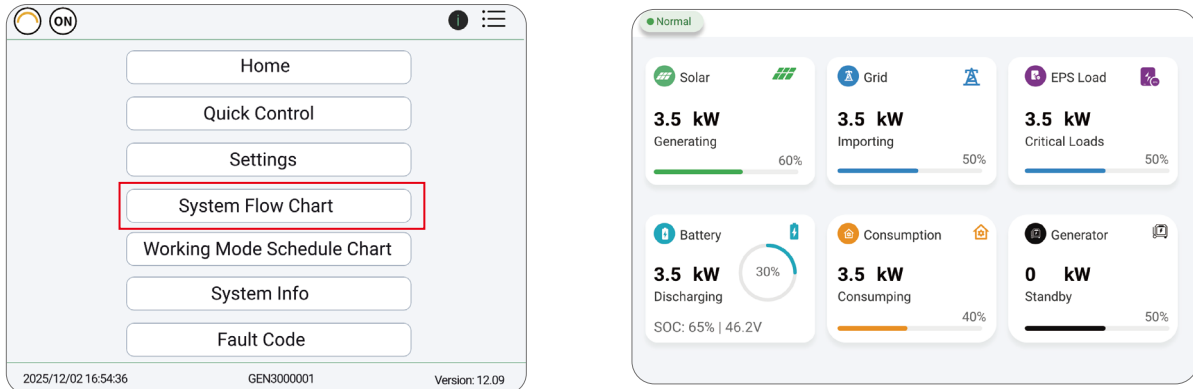

6.2.5 System Information

Select the System Info in the menu, and you'll be able to view detailed real-time solar information, battery information, grid information, and Load output information.

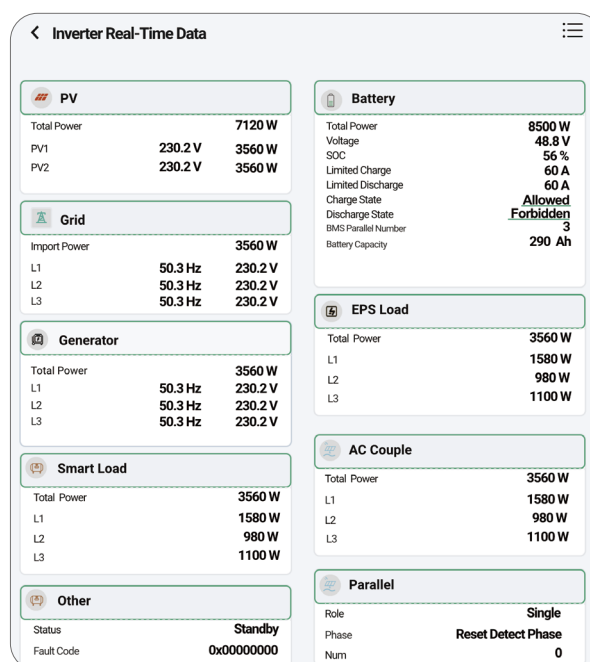
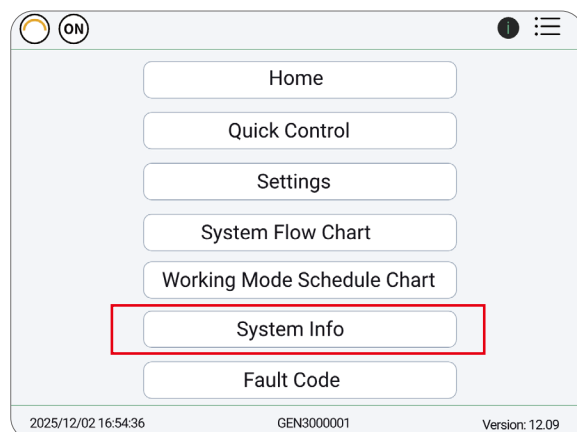





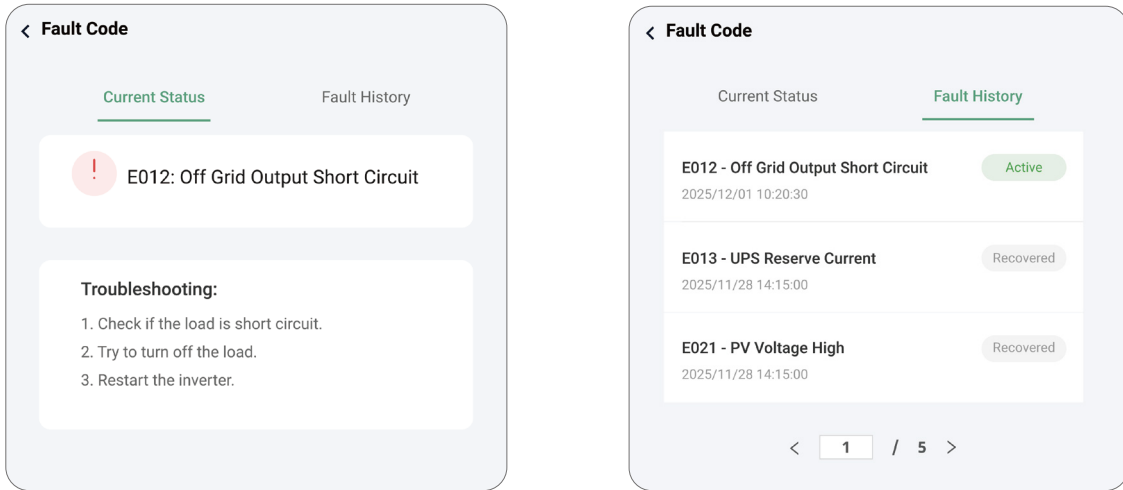

6.2.6 Fault/Alarm Information

Select the Fault Code in the menu, and you'll see all the current and historical fault and warning information on this page.





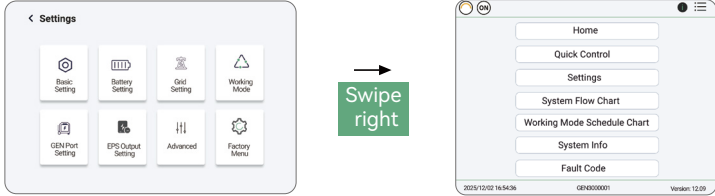

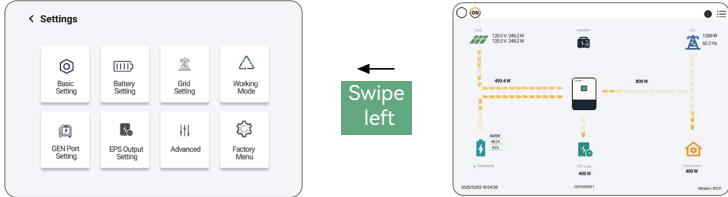
6.3 LCD Screen Settings

6.3.1 Touch operation

Operation	Description
 <p>Tap</p>	<p>Basic tap function.</p>
 <p>Swipe Down</p>	<p>Swipe down on the Home page to enter the Menu page.</p> 
<p>On non-scrollable (horizontal) pages</p>  <p>Swipe Right</p>	<p>Swipe right to return to the previous level.</p> 
<p>On non-scrollable (horizontal) pages</p>  <p>Swipe Left</p>	<p>Swipe left to return directly to the home page.</p> 

6.3.2 Button Operation

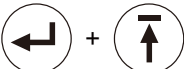
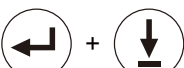
Button	Function
 ESC	Exit
 ENTER	Confirm, Enter menu
 UP	Previous level, Increase
 DOWN	Next level, Decrease
(Press and hold ENTER)  ENTER + UP	Increase (Used for slider bars and similar controls)
(Press and hold ENTER)  ENTER + DOWN	Decrease (Used for slider bars and similar controls)

Note: Long-pressing the UP and DOWN keys will continuously input the corresponding key signals.

6.3.2.1 General Operations

Through button control, move the cursor to this button, press ENTER on the home screen to access the menu options.

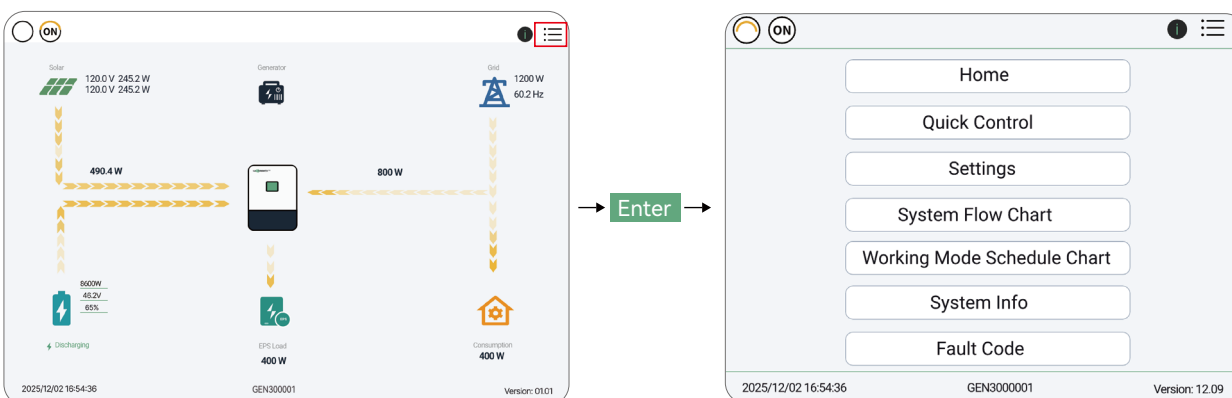

Using the UP and DOWN buttons, select the desired function, then press ENTER to enter. Press ESC to return to the previous level. The options include Home for the main page, System Info for operational data, Fault Code for fault and warning information, and Setting for configuration settings.

6.3.2.2 Setting Operation

Once in the settings interface, you can use the buttons to navigate through various configuration options.

↓	↓	↓	↓
Esc	Up	Down	Enter
↓	↓	↓	↓
None			
	Previous option	Next option	Set the selected option

In the settings menu, press Enter to select the setting item. When using the UP or DOWN button, you need to press and hold the ENTER button at the same time to achieve the scroll wheel effect. Move the cursor to ✓ again and press ENTER to complete the setting (an "OK" animation will be displayed).

↓	↓	↓	↓
Esc	Enter + UP (Press and hold)	Enter + Down (Press and hold)	Enter
↓	↓	↓	↓
None			None
	Previous option	Next option	

6.3.3 Faults & Warnings Function

In the Fault Code menu, you can view real-time fault information. When fault information is refreshed, the page will update accordingly. Click on the corresponding fault, and the pop-up window will prompt a simple description of the corresponding fault.

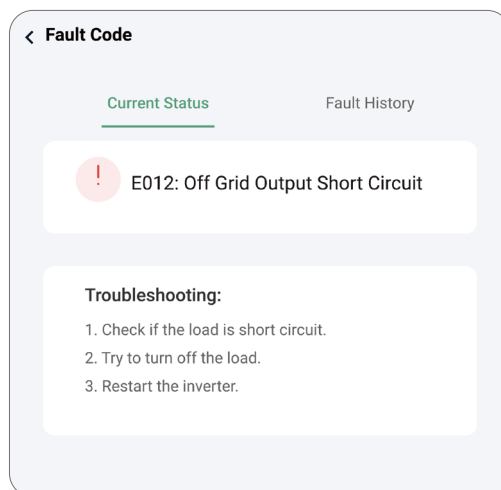

The warning information works similarly. In the Record page, you can view historical fault and warning information.

7. Maintenance & Troubleshooting

7.1 Start and Shutdown the Inverter

7.1.1 Start the Inverter

Operating Procedures

Step 1. Make sure the inverter is properly connected to the batteries, panels, grid, etc(see system wiring diagram).

Step 2. Turn on the battery system firstly, then turn on the built-in battery breaker.

Step 3. Turn on PV DC disconnect switch, make sure the PV voltage of the strings are higher than 140V, and check if the inverter works in PV charge or PV charge back-up mode.

Step 4. Make sure step1 to step3 above work properly before turning on the grid power or generator breaker.

Step 5. Turn on the built-in load breaker before providing power to EPS load.

Step 6. Turn on the built-in grid breaker or generator breaker, check if the inverter can go to bypass mode and on-grid mode normally.

7.1.2 Shut Down the Inverter

DANGER

Do not disconnect the battery, PV and AC input power under load.
If there is emergency issue, and you have to shut down the inverter, please follow the steps as below.

WARNING

After powering off the inverter system, there may still be residual electricity and heat in the enclosure, which could cause electric shock or burns. Therefore, it is recommended to wear insulated gloves and wait for 5 minutes after powering off the inverter system before performing any operations on it.

Operating Procedures

Step 1. Turn off the Grid breaker or Generator of the inverter.

Step 2. Switch off the load breaker.

Step 3. Turn off PV breaker and then battery breaker, waiting for the LCD to go off.

7.2 Regular Maintenance

To ensure the long term and proper operation of the inverter, it is recommended that regular maintenance is carried out as described in this section.

CAUTION

- Do not touch the inverter while it is operating. Certain parts may become hot during operation and can cause burns upon contact.
- Before performing any maintenances—such as system cleaning, electrical connection inspection, or grounding verification—ensure the system is completely shut down and the inverter has fully cooled.
- If the screen or LED indicators become difficult to read due to dust, clean them gently with a soft, dry cloth.
- Do not use solvents, abrasives, or corrosive materials to clean the inverter.

• Inverter Maintenance

- a. Check the inverter every 6 months or 1 year to verify if there are damages on cables, accessories, terminals and the inverter itself.
- b. Check the inverter every 6 months to verify if the operating parameter is normal and there is no abnormal heating or noise from the inverter.
- c. Check the inverter every 6 months to confirm there is nothing that covers the inverter heat sink, if there is, shut-down the inverter and clear the heat sink.

• Battery Maintenance

Follow the manufacturer's requirements on maintenance. When you carry out these works on batteries, please make sure to fully shut-down the inverter for safety consideration.

7.3 Removing the Inverter

DANGER

Before removing the inverter, make sure all power sources are completely disconnected to avoid electric shock or short circuit.

This procedure must be performed by a qualified electrician.

Operating Procedures

Step 1: Power off the system

- Follow the steps described in 7.1 Power OFF the Inverter to ensure complete power disconnection.
- Verify that all indicator lights are off.

Step 2: Disconnect the cables

- Use a screwdriver to remove the PV connection cables.
- Carefully disconnect the battery and communication cables.
- Loosen and remove the AC input and output cables.
- Label each cable for easy reinstallation.



Step 3: Remove the inverter

- Hold the bottom of the inverter firmly with both hands, and use a Phillips screwdriver to remove the two mounting screws on the top and two on the bottom.
- Carefully lift and remove the inverter from the mounting bracket.

Step 4: Packaging and storage

- Repack the inverter using its original packaging materials if available.
- Store the device in a dry, ventilated, and dust-free environment.
- Do not place heavy objects on top of the inverter to prevent deformation or damage.

7.4 LED Displays

LED	Display	Description	Suggestion
Green LED	Solid light 	Working normally	
	Flashing 	Firmware upgrading	Wait till upgrading complete
Red LED	Solid light 	Fault, inverter stop work	Need troubleshooting

7.5 Trouble Shooting & Error List

Once there is any warning or fault occurring, users can troubleshoot according to the LED status and the warning/fault information on the LCD.

Code	Description	Trouble shooting
E000	Internal communication fault1	Restart inverter, if the error still exist, contact us (DSP&M3)
E003	CT Fail	Restart inverter, if the error still exist, contact us
E008	CAN communication error in Parallel System	Check CAN cable connection is connected to the right COM por
E009	No master in parallel system	Check parallel setting for master/Slave part, there should be one master in the system
E012	Off grid output short circuit	Check if the load is short circuit, try to turn off the load and restart inverter
E013	UPS reserve current	Restart inverter, if the error still exist, contact us
E015	Phase Error in three phase parallel system	Check if the AC connection is right for three phase system, there should one at least one inverter in each phase
E016	Relay fault	Restart inverter, if the error still exist, contact us
E017	Internal communication fault2	Restart inverter, if the error still exist, contact us (DSP&M8)
E018	Internal communication fault3	Restart inverter, if the error still exist, contact us (DSP&M3)
E019	Bus voltage high	Check if PV input voltage is higher than 480V
E020	EPS connection fault	Check if EPS and AC connection is in wrong terminal
E021	PV voltage high	Check PV input connection and if PV input voltage is higher than 480V
E022	Hard Over Curr	Restart inverter, if the error still exist, contact us
E024	PV short	Check PV connection
E025	Temperature over range	The internal temperature of inverter is too high, turn off the inverter for 10minutes, restart the inverter, if the error still exist, contact us
E026	Internal Fault	Restart inverter, if the error still exist, contact us (Bus sample)
E028	Sync signal lost in parallel system	Check CAN cable connection is connected to the right COM port
E029	Sync trigger signal lost in parallel system	
E031	Internal communication fault4	Restart inverter, if the error still exist, contact us (DSP&M8)

Code	Description	Trouble shooting
W000	Communication failure with battery	Check if you have choose the right battery brand and communication cable is right, if the warning still exist, contact us
W003	Communication failure with meter	Check communication cable, if the warning still exist, contact us
W004	Battery failure	Inverter get battery fault info from battery BMS, restart battery, if the warning still exist, contact us or battery manufacture
W008	Software mismatch	Please contact LuxpowerTek for firmware update
W009	Fan Stuck	Check if the fan is OK
W012	Bat On Mos	Restart inverter, if the error still exist, contact us
W013	Over temperature	The temperature is a little bit high inside inverter
W015	Bat Reverse	Check the battery connection with inverter is right, if the warning still exist, contact us
W018	AC Frequency out of range	Check AC frequency is in range
W019	AC inconsistent in parallel system2	Reconnect the AC input or Restart inverter, if the error still exist, contact us
W020	PV Isolation low	Check whether the cables are damaged or exposed, whether the connectors are loose, and whether the PV modules are faulty.
W025	Battery voltage high	Check if battery voltage is in normal range
W026	Battery voltage low	Check if battery voltage is in normal range, need to charge the battery if battery voltage is low
W027	Battery open	Check if there is output from the battery and battery connection with inverter is OK
W028	EPS Over load	Check if EPS load is too high
W029	EPS voltage high	Restart inverter, if the error still exist, contact us

7.6 Fan Replacement

Please check and clean the fans regularly (recommended every 6 months). If any issue is detected, replace the fan according to the diagram below. Before disassembling the unit, turn off the system and wait for at least 5 minutes.

Replacement diagram:

(The following fan replacement diagram uses the GEN3-LB-EU 3-8K series as an example. The same fan replacement method also applies to the GEN PRO-LB-EU 8-12K series.)

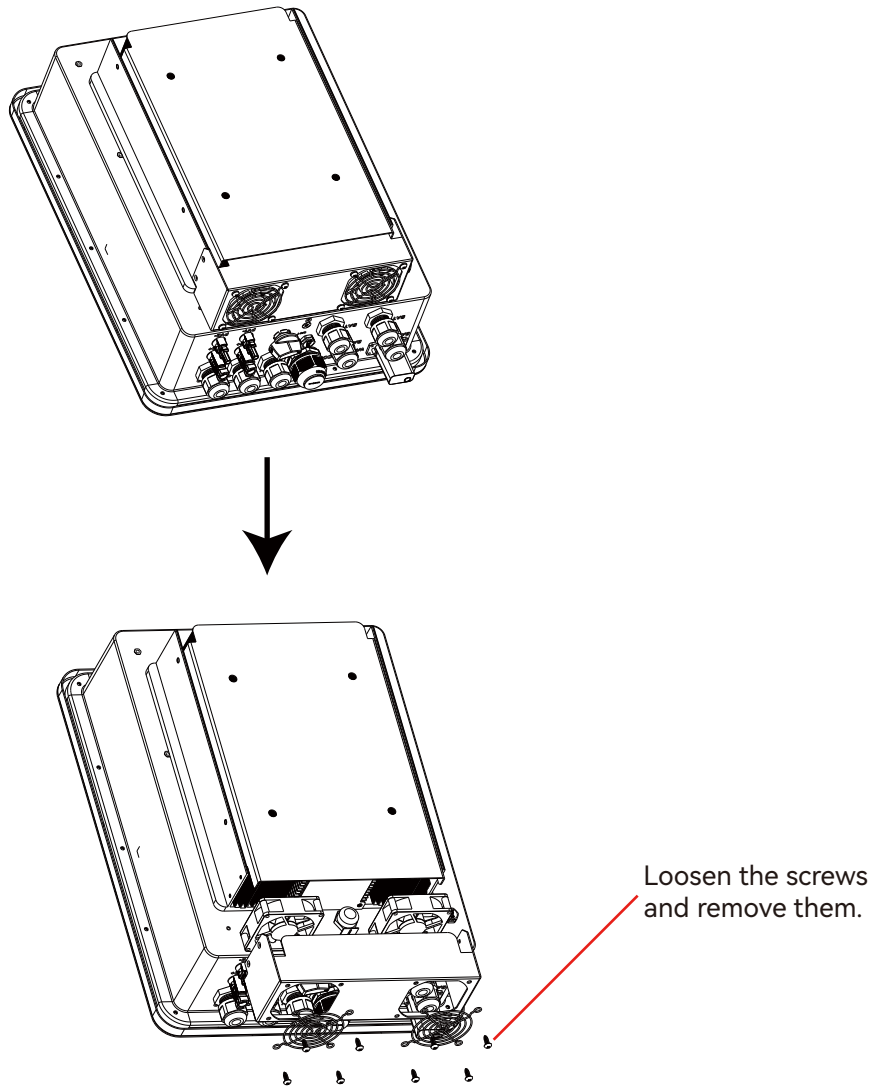

8. Specification

Input (PV DC)	GEN3-LB-EU 3K	GEN3-LB-EU 3.6K	GEN3-LB-EU 4K	GEN3-LB-EU 4.6K
Max. PV input power (W)	6600	7000	7000	8000
Rated PV input voltage (V)			360	
Number of independent MPPT inputs			2	
Max. PV input voltage (V)			530	
MPPT voltage range (V)			150~425	
Start-up voltage (V)			140	
Max. PV input current per MPPT (A)			20	
Max. PV short-circuit current input per MPPT (A)			32	
Battery				
Compatible battery type	Lithium-ion/Lead-Acid battery			
Rated battery voltage (V)	48			
Battery voltage range (V)	40~60			
Max. charging / discharging current (A)	80	80	80	95
Max. charging / discharging power (W)	3600	3600	4000	4600
Force wake up battery from PV function	Yes			
Grid				
Rated AC voltage (V)	230			
Rated AC frequency (Hz)	50 / 60			
Rated AC output current (A)	13	16	20	25
Rated AC output power (W)	3000	3600	4000	4600
Max. AC input current (A)	52			
Max. AC input power (W)	12000			
Rated apparent power (VA)	3000	3600	4000	4600
PF	0.99 (Adjustable from 0.8 leading to 0.8 lagging)			
THDI	<3%			
Max. continuous AC passthrough current (A)	52			
GEN				
Rated GEN voltage (V)	230			
Rated GEN frequency (Hz)	50 / 60			
Rated GEN input current (A)	52			
Rated GEN input power (W)	12000			
AC Output (Backup)				
Rated output power (W)	3000	3600	4000	4600
Rated output current (A)	13	16	20	25
Rated output voltage (V)	230			
Rated output frequency (Hz)	50 / 60			
Surge power, duration	2 × rated power for 1s			
Switching time	7ms			
Wave form	Sine wave			
THDV	<5%			
Efficiency				
MPPT efficiency	99.9%			
Max. efficiency	97.0%			
Max. charge / discharge efficiency	95.0%			
Protection				
Over current / voltage protection	Yes			
Anti-islanding protection	Yes			
AC Short-circuit current protection	Yes			
Leakage current protection	Yes			
AFCI	Optional			
Ground fault monitoring	Yes			
Grid monitoring	Yes			
PV DC switch	Yes			
AC / DC surge protection	Type II			
General				
Dimensions (W × H × D)	416 × 538.5 × 229.5 mm / 16.38 × 21.2 × 9.04 in			
Weight	22.5 kg / 49.6 lbs			
Ingress protection rating	IP66			
Relative humidity	0~100%			
Operating environment temperature range (°C)	-25~60 (>45 derating)			
Storage temperature range (°C)	-40~65			
Display & Communication interface	LCD, RS485, Wifi, CAN			
Warranty	5 years			
Cooling method	Smart Cooling			
Topology on AC / Battery side	Transformer			
Noise emission (dB)	30			
Max. operating altitude (m)	2000 (> 2000m derating)			

Input (PV DC)	GEN3-LB-EU 5K	GEN3-LB-EU 6K	GEN3-LB-EU 6.5K
Max. PV input power (W)	8000	12000	12000
Rated PV input voltage (V)		360	
Number of independent MPPT inputs		2	
Max. PV input voltage (V)		530	
MPPT voltage range (V)		150~425	
Start-up voltage (V)		140	
Max. PV input current per MPPT (A)		20	
Max. PV short-circuit current input per MPPT (A)		32	
Battery			
Compatible battery type	Lithium-ion/Lead-Acid battery		
Rated battery voltage (V)	48		
Battery voltage range (V)	40~60		
Max. charging / discharging current (A)	120	125	135
Max. charging / discharging power (W)	5000	6000	6500
Force wake up battery from PV function	Yes		
Grid			
Rated AC voltage (V)	230		
Rated AC frequency (Hz)	50 / 60		
Rated AC output current (A)	21.7	26	28.2
Rated AC output power (W)	5000	6000	6500
Max. AC input current (A)	52		
Max. AC input power (W)	12000		
Rated apparent power (VA)	5000	6000	6500
PF	0.99 (Adjustable from 0.8 leading to 0.8 lagging)		
THDI	<3%		
Max. continuous AC passthrough current (A)	52		
GEN			
Rated GEN voltage (V)	230		
Rated GEN frequency (Hz)	50 / 60		
Rated GEN input current (A)	52		
Rated GEN input power (W)	12000		
AC Output (Backup)			
Rated output power (W)	5000	6000	6500
Rated output current (A)	21.7	26	28.2
Rated output voltage (V)	230		
Rated output frequency (Hz)	50 / 60		
Surge power, duration	2 × rated power for 1s		
Switching time	7ms		
Wave form	Sine wave		
THDV	<5%		
Efficiency			
MPPT efficiency	99.9%		
Max. efficiency	97.0%		
Max. charge / discharge efficiency	95.0%		
Protection			
Over current / voltage protection	Yes		
Anti-islanding protection	Yes		
AC Short-circuit current protection	Yes		
Leakage current protection	Yes		
AFCI	Optional		
Ground fault monitoring	Yes		
Grid monitoring	Yes		
PV DC switch	Yes		
AC / DC surge protection	Type II		
General			
Dimensions (W × H × D)	416 × 538.5 × 229.5 mm / 16.38 × 21.2 × 9.04 in		
Weight	22.5 kg / 49.6 lbs		
Ingress protection rating	IP66		
Relative humidity	0~100%		
Operating environment temperature range (°C)	-25~60 (>45 derating)		
Storage temperature range (°C)	-40~65		
Display & Communication interface	LCD, RS485, Wifi, CAN		
Warranty	5 years		
Cooling method	Smart Cooling		
Topology on AC / Battery side	Transformer		
Noise emission (dB)	30		
Max. operating altitude (m)	2000 (> 2000m derating)		

Input (PV DC)	GEN3-LB-EU 7K	GEN3-LB-EU 8K
Max. PV input power (W)		12000
Rated PV input voltage (V)		360
Number of independent MPPT inputs		2
Max. PV input voltage (V)		530
MPPT voltage range (V)		150-425
Start-up voltage (V)		140
Max. PV input current per MPPT (A)		20
Max. PV short-circuit current input per MPPT (A)		32
Battery		
Compatible battery type	Lithium-ion/Lead-Acid battery	
Rated battery voltage (V)		48
Battery voltage range (V)		40~60
Max. charging / discharging current (A)	147	180
Max. charging / discharging power (W)	7000	8000
Force wake up battery from PV function		Yes
Grid		
Rated AC voltage (V)		230
Rated AC frequency (Hz)		50 / 60
Rated AC output current (A)	30.5	34.7
Rated AC output power (W)	7000	8000
Max. AC input current (A)		52
Max. AC input power (W)		12000
Rated apparent power (VA)	7000	8000
PF	0.99 (Adjustable from 0.8 leading to 0.8 lagging)	
THDI		<3%
Max. continuous AC passthrough current (A)		52
GEN		
Rated GEN voltage (V)		230
Rated GEN frequency (Hz)		50 / 60
Rated GEN input current (A)		52
Rated GEN input power (W)		12000
AC Output (Backup)		
Rated output power (W)	7000	8000
Rated output current (A)	30.5	34.7
Rated output voltage (V)		230
Rated output frequency (Hz)		50 / 60
Surge power, duration	2 × rated power for 1s	
Switching time		7ms
Wave form		Sine wave
THDV		<5%
Efficiency		
MPPT efficiency		99.9%
Max. efficiency		97.0%
Max. charge / discharge efficiency		95.0%
Protection		
Over current / voltage protection		Yes
Anti-islanding protection		Yes
AC Short-circuit current protection		Yes
Leakage current protection		Yes
AFCI		Optional
Ground fault monitoring		Yes
Grid monitoring		Yes
PV DC switch		Yes
AC / DC surge protection		Type II
General		
Dimensions (W × H × D)	416 × 538.5 × 229.5 mm / 16.38 × 21.2 × 9.04 in	
Weight	22.5 kg / 49.6 lbs	
Ingress protection rating	IP66	
Relative humidity	0-100%	
Operating environment temperature range (°C)	-25~60 (>45 derating)	
Storage temperature range (°C)	-40~65	
Display & Communication interface	LCD, RS485, Wifi, CAN	
Warranty	5 years	
Cooling method	Smart Cooling	
Topology on AC / Battery side	Transformer	
Noise emission (dB)	50	
Max. operating altitude (m)	2000 (> 2000m derating)	

Input (PV DC)	GEN PRO-LB-EU 8K	GEN PRO-LB-EU 10K	GEN PRO-LB-EU 12K
Max. PV input power (W)	16000	21000	
Rated PV input voltage (V)	360		
Number of independent MPPT inputs	3(1:1:1)		
Max. PV input voltage (V)	530		
MPPT voltage range (V)	150~425		
Start-up voltage (V)	140		
Max. PV input current per MPPT (A)	20		
Max. PV short-circuit current input per MPPT (A)	32		
Battery			
Compatible battery type	Lithium-ion/Lead-Acid battery		
Rated battery voltage (V)	48		
Battery voltage range (V)	40~60		
Max. charging / discharging current (A)	180	230	250
Max. charging / discharging power (W)	8000	10000	12000
Force wake up battery from PV function	Yes		
Grid			
Rated AC voltage (V)	230		
Rated AC frequency (Hz)	50 / 60		
Rated AC output current (A)	34.7	43.5	52
Rated AC output power (W)	8000	10000	12000
Max. AC input current (A)	100		
Max. AC input power (W)	23000		
Rated apparent power (VA)	8000	10000	12000
PF	0.99 (Adjustable from 0.8 leading to 0.8 lagging)		
THDI	<3%		
Max. continuous AC passthrough current (A)	100		
GEN			
Rated GEN voltage (V)	230		
Rated GEN frequency (Hz)	50 / 60		
Rated GEN input current (A)	80		
Rated GEN input power (W)	18400		
AC Output (Backup)			
Rated output power (W)	8000	10000	12000
Rated output current (A)	34.7	43.5	52
Rated output voltage (V)	230		
Rated output frequency (Hz)	50 / 60		
Surge power, duration	2 × rated power for 1s		
Switching time	7ms		
Wave form	Sine wave		
THDV	<5%		
Efficiency			
MPPT efficiency	99.9%		
Max. efficiency	97.3%		
Max. charge / discharge efficiency	95.0%		
Protection			
Over current / voltage protection	Yes		
Anti-islanding protection	Yes		
AC Short-circuit current protection	Yes		
Leakage current protection	Yes		
AFCI	Optional		
Ground fault monitoring	Yes		
Grid monitoring	Yes		
PV DC switch	Yes		
AC / DC surge protection	Type II		
General			
Dimensions (W × H × D)	417 × 615.5 × 229.5mm / 16.42 × 24.23 × 9.04 in		
Weight	30.8kg / 67.9lbs		
Ingress protection rating	IP66		
Relative humidity	0~100%		
Operating environment temperature range (°C)	-25~60 (>45 derating)		
Storage temperature range (°C)	-40~65		
Display & Communication interface	LCD, RS485, Wifi, CAN		
Warranty	5 years		
Cooling method	Smart Cooling		
Topology on AC / Battery side	Transformer		
Noise emission (dB)	50		
Max. operating altitude (m)	2000 (> 2000m derating)		

■ YOUR RELIABLE ENERGY SOLUTION PARTNER



Lux Power Technology Co., Ltd
Headquarter: +86 755 8520 9056
www.luxpowertek.com
Contact us: info@luxpowertek.com



092.20151AB