

# ECO BEAST PRO

## All-in-One ESS User Manual

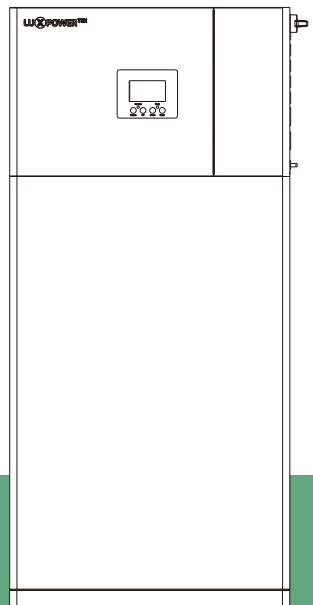

Copyright© 2026 Lux Power Technology Co., Ltd. All Rights Reserved. This manual, protected by the copyright and intellectual property rights of Lux Power Technology. No part of this document may be modified, copied, or reproduced without prior written permission.

All brands and trademarks mentioned belong to their respective owners.

Please read carefully to understand product reliability and warranty eligibility.

For detailed warranty information, refer to the Lux Power Technology Limited Warranty.

This manual is intended for professional service providers. Nothing in this document constitutes an express or implied warranty.

Descriptions may include forward-looking statements. Actual conditions may differ. This document is provided for reference only and is subject to change without notice by Lux Power Technology Co., Ltd.



Website



YouTube



Facebook

 [www.luxpowertek.com](http://www.luxpowertek.com)



Scan to download

## Table Of Contents

<b>Information on this Manual</b> . . . . .	1
Validity . . . . .	1
Scope . . . . .	1
Target Group . . . . .	1
Safety Instructions . . . . .	1
<b>1. Brief Introduction</b> . . . . .	2
1.1 Features of the inverter . . . . .	2
1.2 Interface of the inverter . . . . .	3
1.3 Packing list . . . . .	4
<b>2. Installation</b> . . . . .	6
2.1 Preparation . . . . .	6
2.2 Mounting the Unit . . . . .	8
2.3 Battery Connection . . . . .	9
2.3.1 Battery Power Cable Connection . . . . .	9
2.3.2 Lithium Battery Connection . . . . .	9
2.4 CT . . . . .	10
2.5 AC Input/Output Connection . . . . .	12
2.6 Ground Cable Installation . . . . .	13
2.7 PV Connection . . . . .	14
2.8 Working with Generator . . . . .	14
2.9 Smart load Connection . . . . .	19
2.10 AC Coupling Settings . . . . .	20
2.11 Parallel Function . . . . .	21
2.12 Power and EPS ON/OFF . . . . .	24
<b>3. Working Modes</b> . . . . .	24
3.1 Offgrid inverter modes introduction . . . . .	24
3.2 Working Modes related setting description . . . . .	26
3.3 Working as a hybrid inverter Related setting . . . . .	27

- 4. LCD Display and settings** ..... 29
- 4.1 LED Display ..... 29
- 4.2 LCD Display ..... 30
- 4.3 Inverter Status Display ..... 31
- 4.4 LCD Settings ..... 32
- 5. Eco Beast Pro Inverter Monitoring System** .....48
- 6. Specifications** .....52
- 7. Trouble Shooting & Error List** .....56

## Revision History

Version	Date	Description
UM-AIO03001E01	2026.03.17	First official release.

## Information on this Manual

### Validity

This manual is valid for the following devices: Eco Beast Pro 6500

### Scope

This manual provides the installation, operation and troubleshooting of this unit, please read this manual carefully before installations and operations.

### Target Group

For qualified persons and endusers. Qualified persons and end users must have the following skills:

- Knowledge about this unit operation
- Training in deal with the security issues associated with installations and electrical safety
- Training in the installation and commissioning of electrical devices and installations
- Knowledge of the applicable local standards and directives

### Safety Instructions

**WARNING:** This chapter contains important safety and operating instructions. Read and keep this manual for future reference.

- All the operation and connection need to be operated by qualified persons.
- Before using the unit, read all instructions and cautionary marking on the unit. Any damage caused by inappropriate operation is not warranted by Luxpower.
- All the electrical installation must comply with the local electrical safety standards.
- Do not disassemble the unit. Take it to a qualified service center when service or repair is required, incorrect re-assembly may result in a risk of electric shock or fire. Do not open inverter cover or change any components without Luxpower's authorization, otherwise the warranty commitment for the inverter will be invalid.
- To reduce risk of electric shock, disconnect all wirings before attempting any maintenance or cleaning, turning off the unit will not reduce this risk.
- **CAUTION**–To reduce risk of injury, charge only deep-cycle lead-acid type rechargeable batteries and lithium batteries, other types of batteries may burst, causing personal injury and damage.
- **NEVER** charge a frozen battery.
- For optimum operation of this unit, please follow required spec to select appropriate cable size and breaker.
- Please strictly follow installation procedure when you want to disconnect AC or DC

terminals, please refer to INSTALLATION section of this manual for the details.

- GROUNDING INSTRUCTIONS - This unit should be connected to a permanent grounded wiring system, be sure to comply with local requirements and regulation to install this inverter.
- Never short-circuit the AC and DC terminals. Do not connect the inverter to the utility grid if the DC input side is short-circuited.

## 1. Brief Introduction

### 1.1 Features of the inverter

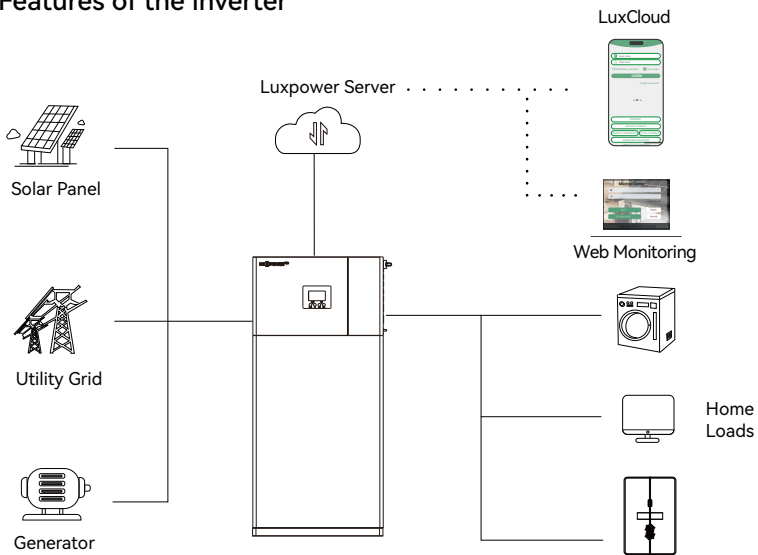

Eco Beast Pro 6500 is a multifunctional, high frequency pure sine wave Eco Beast Pro Energy Storage inverter, features:

- Applicable for pure off grid inverter/backup power /self-consumption/on grid situation
- Integrated with 2 MPPT solar charge controllers, MPPT ranges 120V~440V
- Rated power 6500W, power factor 1
- Be able to run with or without battery in ongrid and off-grid mode
- With separated generator input interface, able to control generator remotely
- Solar and utility grid can power loads at the sametime
- With integrated advanced parallel function, up to 16pcs max paralleling
- Support CAN/RS485 for Li-ion battery BMS communication
- WIFI/GPRS remote monitoring, setting and firmware update, support website, free IOS/Android APP



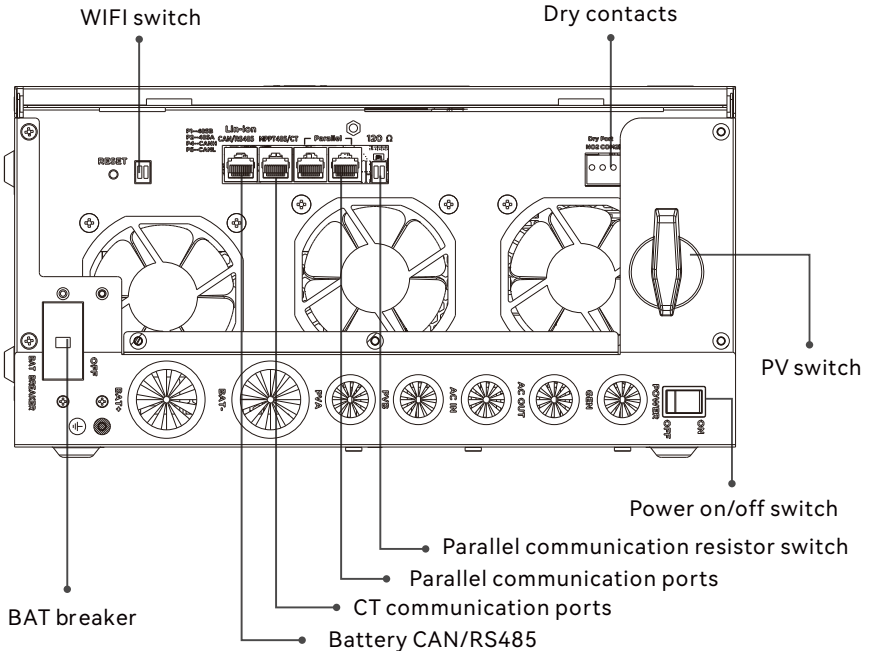
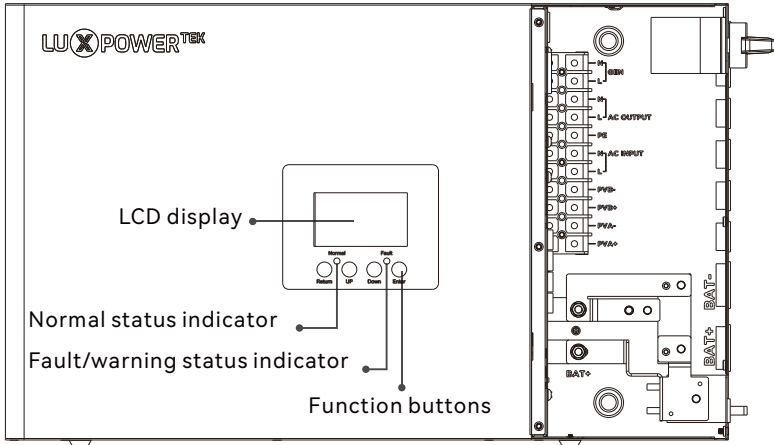

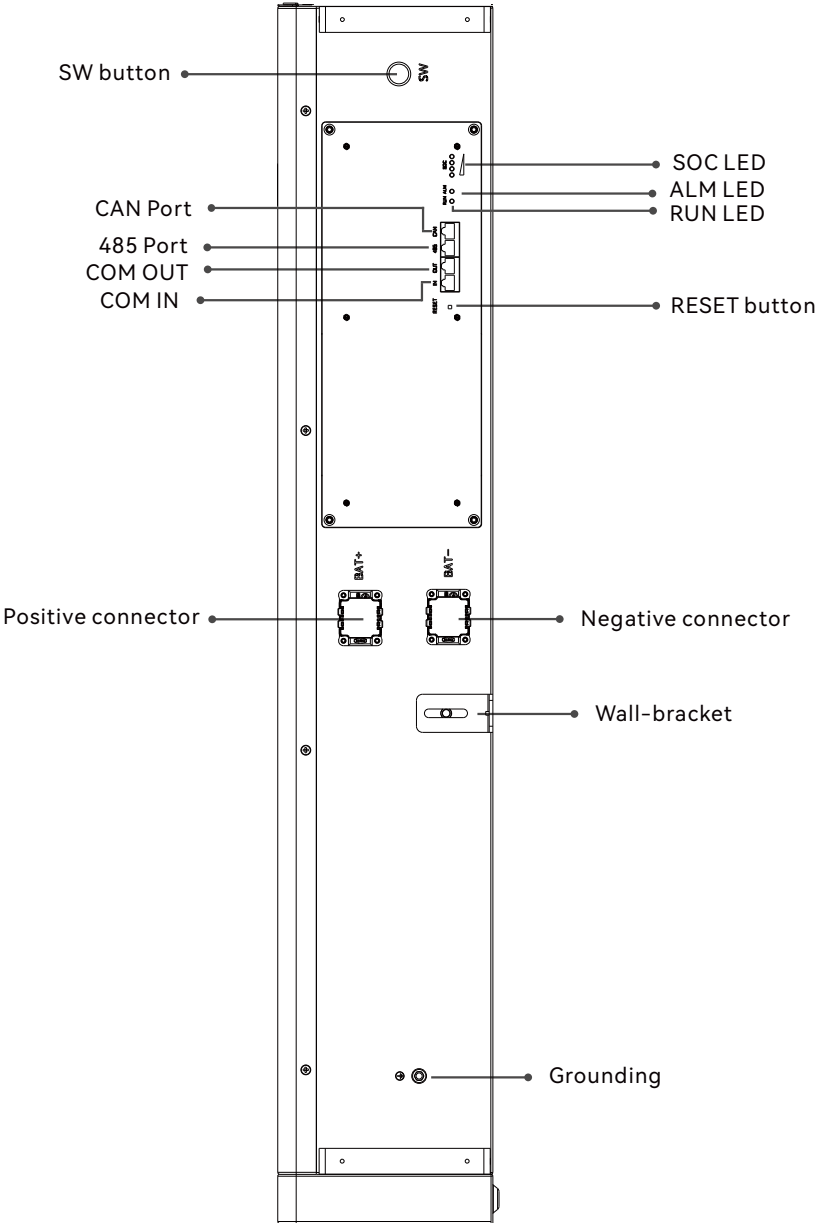





## 1.2 Interface of the inverter





### 1.3 Packing List

Before installation, please inspect the unit. Be sure that nothing inside the package is damaged. You should have received the following items in the package:

 <p>ECO Hybrid inverter ×1</p>	 <p>User Manual ×1</p>	 <p>Expansion Screw and Tube ×2</p>	 <p>CT ×1 (1000:1)</p>
 <p>Cross Head Screw ×5 / Nut ×4</p>	 <p>Battery ×1</p>	 <p>Base Bracket ×1</p>	 <p>Battery communication cable L=485mm ×1 (Orange)</p>
 <p>Battery Connection Cable BAT+ (Red) ×1 BAT- (Black) ×1</p>	 <p>Wall Mount Bracket ×2 (for securing to the wall)</p>	 <p>Power Switch Cover ×1</p>	

### Storing the Inverter

The inverter must be stored appropriately if not installed immediately, refer to below figure.

#### ⚠ CAUTION

- The inverter and its components must be stored in its original packaging.
- The storage temperature should be within  $-25\sim 60^{\circ}\text{C}$  and humidity within  $0\sim 85\%$ .
- The packing should be upright and maximum stacked layers is 6.
- Do not directly exposed the inverter and its packaging to sunshine, raindrops and keep away from corrosion.

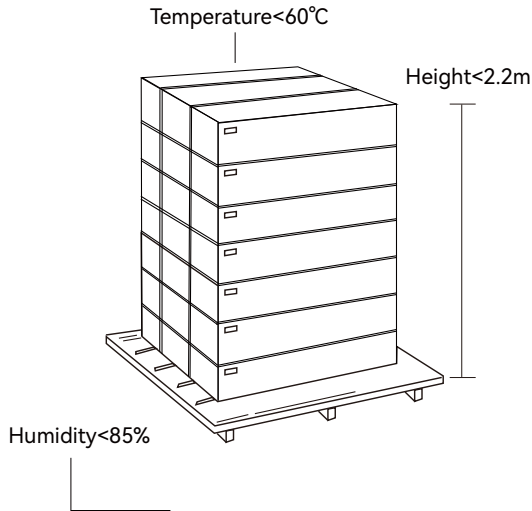

## 2. Installation

### 2.1 Preparation

Please prepare the breakers and cables in advanced before installation.

**1. Battery connection:** For safe operation and compliance with regulations, use the battery power cable provided with the accessories. If a custom cable is required, please follow the recommended cable specifications.

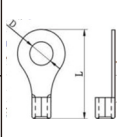
Model	Maximum Amperage	Battery capacity	Wire Size	Ring Terminal			Torque value	
				Cable mm <sup>2</sup>	Dimensions			
				d2(mm)	L(mm)			
Eco Beast Pro 6500	140A	≥200AH	1*2AWG	33.6	6.4	39.2	4~5 Nm	

**2. AC connection:** Please install a separate AC breaker between inverter and AC input power source, inverter and AC output load. This will ensure the inverter can be securely disconnected during maintenance and fully protected from over current of AC input. The recommended spec of AC breaker is 50A. Recommended AC input/AC output/GEN cable size for each inverter.

Model	Gauge	Cable (mm <sup>2</sup> )	Torque value
Eco Beast Pro 6500	10AWG	6	2.0Nm

3. **PV Connection:** Please install separately a DC circuit breaker between inverter and PV modules. The recommended of DC breaker is 600V/25A. It's very important for system safety and efficient operation to use appropriate cable for PV module connection. To reduce risk of injury, please use the proper recommended cable size as below:

Model	Gauge	Cable (mm <sup>2</sup> )	Torque value
Eco Beast Pro 6500	1×10AWG	6	2.0Nm

4. Before connecting all wiring, please take off bottom cover by removing 5 screws as shown below.

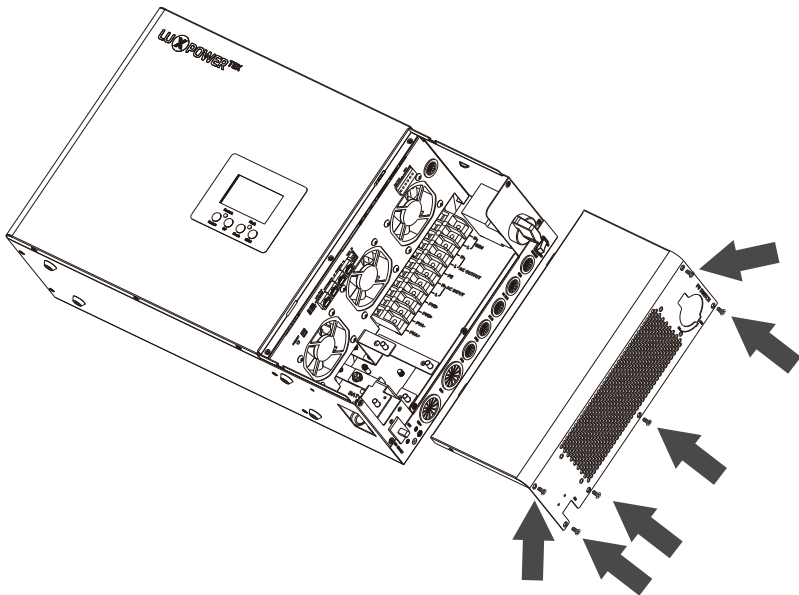

## 2.2 Mounting the Unit

### ● NOTICE

**Consider the following points before selecting where to install:**

- Mount on a solid surface
- Do not mount the inverter on flammable construction materials.
- For proper air circulation to dissipate heat, allow a clearance of approx. 20cm to the side and approx. 50 cm above and below the unit.
- The ambient temperature should be between 0°C and 55°C to ensure optimal operation.
- The recommended installation position is to be adhered to the wall vertically.

### Steps to mounting the unit

**Step1.** Use the wall-mounting bracket as the template to mark the position of the 4 holes, then drill 8mm holes and make sure the depth of the holes is deeper than 50mm.

**Step2.** Install the expansion tubes into the holes and tight them, then use the expansion screws (packaged together with the expansion tubes) to install and fix the wall-mounting bracket on the wall.

**Step3.** Install the inverter on the wall-mounting bracket and lock the inverter using the security screws.

**Step4.** Remove the M4 screws from the accessory kit, then use them to connect and securely fasten the inverter to the battery.

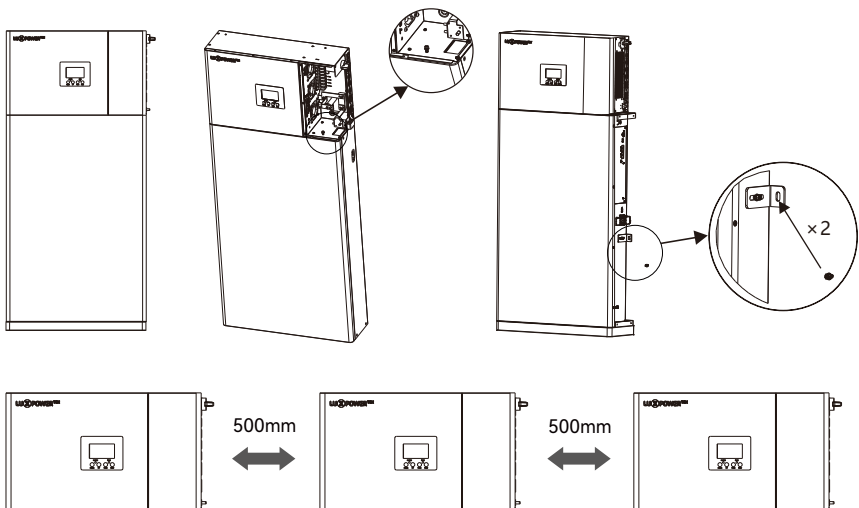

## 2.3 Battery Connection

### 2.3.1 Battery Power Cable Connection

Note: for lead acid battery, the recommended charge current is 0.2C ( C to battery capacity)

1. Please follow below steps to implement battery connection:
2. Take out the battery power cable from the accessories. Before connecting the battery power cable, ensure that both the battery switch and the inverter breaker are in the OFF position.
3. Insert the ring terminal of battery cable flatly into battery connector of inverter and make sure the bolts are tightened with torque of 4 ~ 5Nm. Make sure polarity of the battery is correctly connected and ring terminals are tightly screwed to the battery terminals.

### 2.3.2 Lithium Battery Connection

If choosing lithium battery for Eco Beast Pro 6500, please make sure the battery BMS is compatible with Luxpower inverter. Please check the compatible list in the LuxpowerTek website.

Please follow below steps to implement lithium battery connection:

1. Connect power cable between inverter and battery.
2. Connect the CAN or RS485 communication cable between inverter and battery. If you do not get the communication cable from inverter manufacturer or battery manufacturer, please make the cable according to the PIN definition
3. Lithium battery configuration, in order to communicate with battery BMS, you should set the battery type to “Li-ion” in Program “03” by LCD and choose the right battery brand (for details, please check the LCD setting chapter), users can also choose the battery type and brand by monitor system.

If using a Luxpower battery, select lithium type for option 6: Luxpower; for Hina battery, select lithium type option 1: Hina Battery.

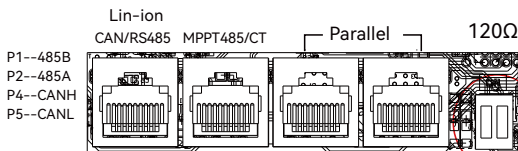

Blue Color Switch		
Pin	RS 485 port	CAN port
1	RS 485 B	---
2	RS 485 A	---
3	---	---
4	---	CANH
5	---	CANL
6/7/8	---	---

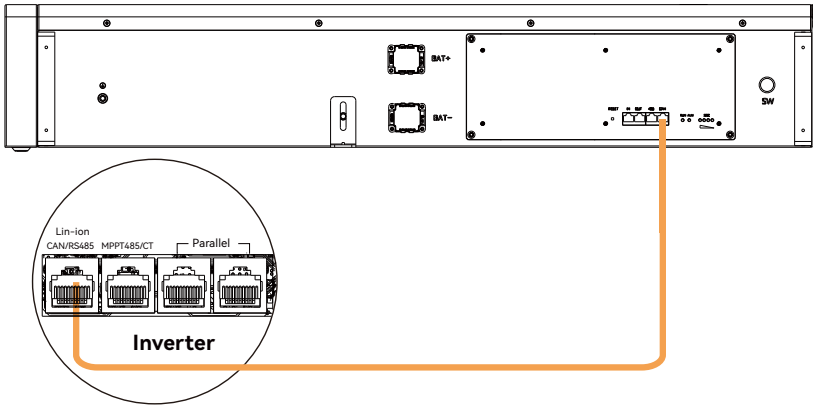

## 2.4 CT

To measure the power imported from and exported to the grid, the CT must be installed at the service entry point in or near the main service panel. External Grid CT "function is off by default, and if you need inverter to export power to compensate the grid loads, you can set "External Grid CT "function to "Enable" state. Please refer to section 4.4 LCD Settings for detected setting info.

### CT Port Pin definition

The CT interface for CT connection is a RJ45 port

Pin	Description
	CT
1/3	B
2/4	A
5	CT1N
6	CT1P
7	B2
8	A2

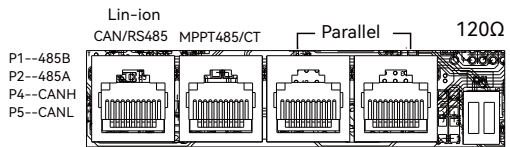

Pin12345678



Please refer to the connection diagram for the correct positions of Grid CT and clamp the CT on the wires at the service entry point in the main service panel. The arrow on the CT is pointing to the inverter. (\*\*\*)Incorrectly install CT will cause The Display to show incorrect information and features of the inverter will not function correctly) If the CT is in a wrong direction, there is an option you can change the direction of the CT on your invertercall: CT Direction Reversed in Advanced Tab. You would not need to go change it physically.

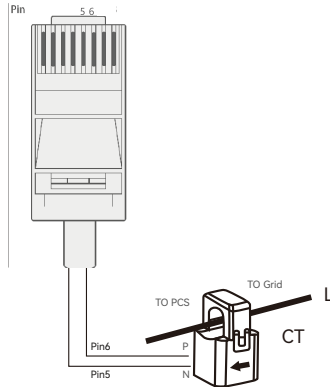

### CT Clamp Ratio

The inverter support 3 ratios of CT clamp - 1000:1, 2000:1 and 3000:1. The CT ratio in the accessory bag is 1000:1. If you are using a 3rd party CT, please ensure the CT ratio is one of them, and select the correct CT ratio setting in the inverter monitor page or on the inverter LCD.

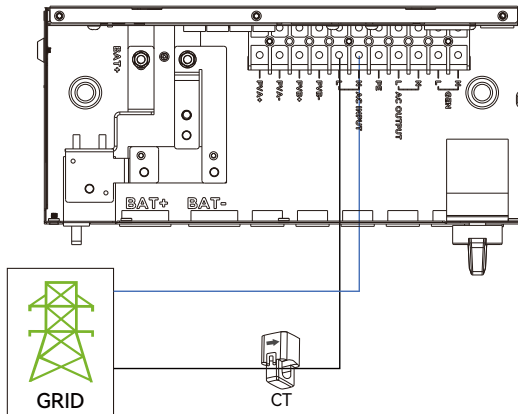

## 2.5 AC Input/Output Connection

**CAUTION**

- There are two terminal blocks with “IN” and “OUT” markings. Please do NOT mis-connect input and output connectors.
- Be sure to connect AC wires with correct polarity. If L and N wires are connected reversely, it may cause utility short-circuited when these inverters are worked in parallel operation.

Please follow below steps to implement AC input/output connection:

1. Before making AC input/output connection, be sure to open DC protector or disconnected first.
2. Prepare the AC input and output wires. Once identified, strip approximately 10mm (≈3/8 in.) of insulation from the wires.
3. Insert AC input wires according to polarities indicated on terminal block and tighten the terminal screws. Be sure to connect PE protective conductor first.
4. Insert AC output wires according to polarities indicated on terminal block and tighten terminal screws. Be sure to connect PE protective conductor first.
5. Make sure the wires are securely connected.

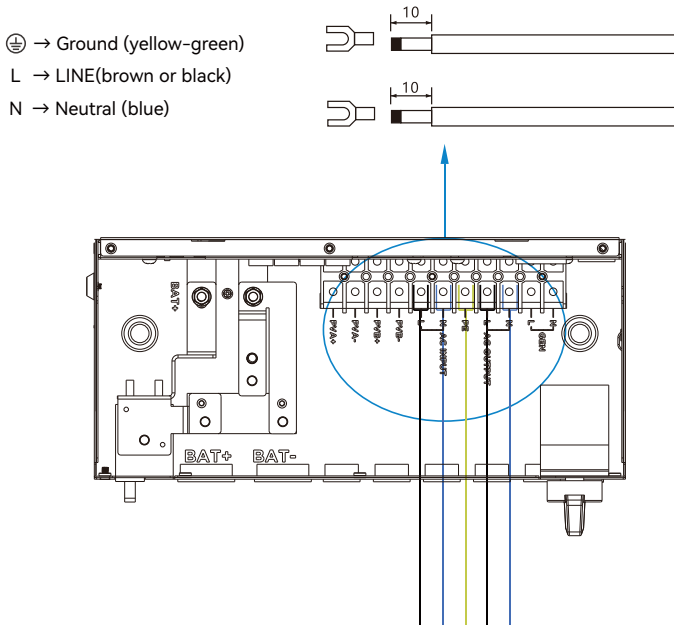

## 2.6 Ground Cable Installation

To ensure electrical safety and proper system grounding, please follow the instructions below for installing the ground cable to the inverter chassis.

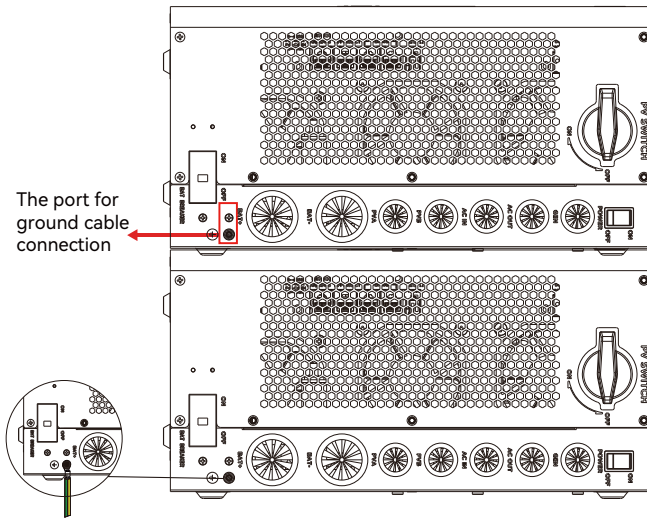

### Required Materials

Single-core copper wire (solid or stranded)

Cross-sectional area: 4–6 mm<sup>2</sup> (minimum 4 mm<sup>2</sup> recommended)

Ring terminal (OT type, size: M4 or M5 depending on inverter design)

Crimping tool

Torque wrench

Step

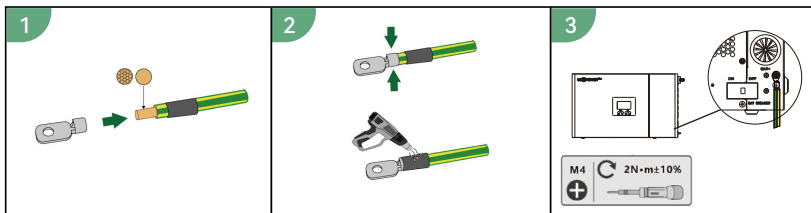

### \* Important:

- When using multiple inverters in parallel, all chassis ground cables must be connected to the same ground point to avoid voltage differences between units.

### Additional Notes

- The chassis ground does not replace the PE cable of the AC output.
- If local standards require equipotential bonding, please use a dedicated grounding busbar to connect PV module frames, racks, and other components accordingly.

**▲ WARNING:** Improper grounding may cause electric shock hazards or equipment malfunction. Always follow local electrical codes and standards.

## 2.7 PV Connection

Please follow below steps to implement PV module connection:

1. Remove insulation sleeve 10mm for positive and negative conductors.
2. Check correct polarity of connection cable from PV modules and PV input connectors.
3. Connect positive pole (+) of connection cable to positive pole (+) of PV input connector. Connect negative pole (-) of connection cable to negative pole (-) of PV input connector.
4. Make sure the wires are securely connected.

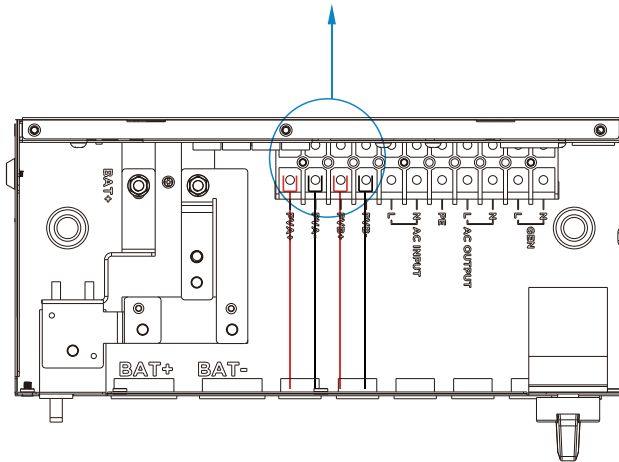

## 2.8 Working with Generator

### 2.8.1 Generator system connection

The Eco Beast Pro 6500 can use a generator for backup power during grid failures. When selecting a generator, ensure it provides sufficient power and maintains a frequency with a Total Harmonic Distortion (THD) of less than 3%. As a general guideline, the generator should be at least 1.5 times the inverter's output to accommodate both load powering and battery charging. The table below lists the recommended generator capacities for optimal performance.

Number of inverters in parallel	Generator Capacity
1	>10KW
2	>15KW
3	>20KW
4	>25KW

This all-in-one ess product can work with a generator and includes a dedicated Gen port for generator connection.

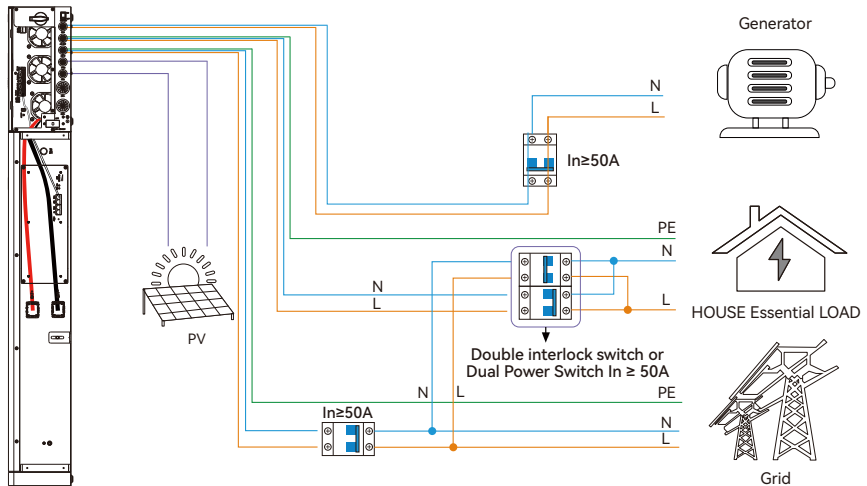

When properly wired and configured, the generator, if compatible with remote start, will start automatically when the battery voltage/SOC is lower than the cut-off value or there is a charge request from the BMS. When the generator is running, it will charge the batteries and excess AC power will be diverted to the AC output (LOAD) to power loads.

## 2.8.2 Integrated two-wire Start/Stop



The Dry port (NO2, COM2) could be used to deliver signal to external device when battery voltage reaches warning level. The GEN port (NO1, COM1,) could be used to wake-up the Generator and then the generator can charge the battery.

Reminder:

Notice: NO---Normal open

Dry Port Relay Maximum Specification: 250VAC 5A

Gen Port Relay Maximum Specification: 250VAC 5A

Unit Status	Condition		Dry port	GEN
				
Power Off	Inverter is off and no output is powered.		Open	Open
Power On	Without Grid	Battery voltage < Low DC warning Voltage	Close	Close
		Battery voltage > Setting value or battery charging reaches floating stage	Open	Open
	With Grid	Battery voltage < Low DC warning Voltage	Close	Open
		Battery voltage > Setting value or battery charging reaches floating stage	Open	Open

### 2.8.3 Generator AC connection

L→LINE (brown or black)                      N→Neutral (blue)

1. Before making Generator connection, be sure to open DC protector or disconnected first.
2. Remove insulation sleeve 10mm for 2 conductors.
3. Insert L and N wires according to polarities indicated on terminal block and tighten the terminal screws
4. Make sure the wires are securely connected.
5. Finally, after connecting all wiring, please put bottom cover back by screwing two screws as shown below.

Please follow the steps listed below to ensure the generator connections are properly installed.

**Step 1:** Before making any wiring connections, ensure the inverter (s) are powered off, the generator is powered off, and all circuit breakers are open (off) to prevent damage to the unit.

**Step 2:** Properly identify the generator’s output lines. According to European wiring standards, the Live (L) wire will be black, Neutral (N) will be blue, and Ground (PE) will be green/yellow. Once identified, strip approximately 10mm (≈3/8 in.) of insulation from the wires.

**Step 3:** Ground the generator’s output ground to the Ground Bus (labeled PE) of the inverter.

**Step 4:** Connect the Live (L) wire to the GEN port’s L terminal and the Neutral (N) wire to the GEN port’s N terminal.

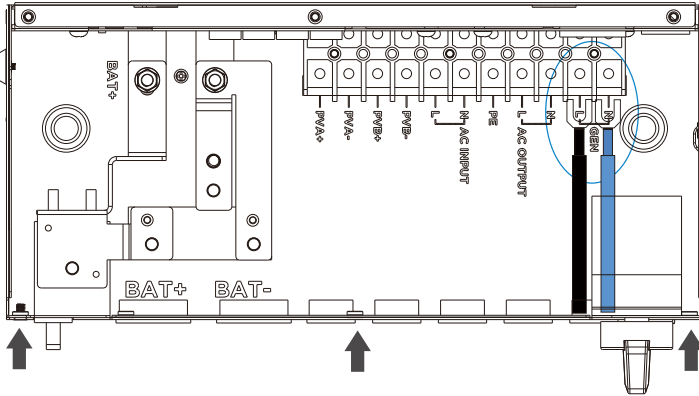

### 2.8.4 Generator start and stop settings

Using the Luxpower Monitoring Software, navigate to the “Maintenance” page where “Remote Set” will be automatically selected. Scroll to the “Generator” section and select the “Generator Charge Type” (see screenshot below). Typically, lead-acid batteries are charged based on voltage, while lithium batteries are charged based on SOC (State of Charge).

**Generator**

---

**Generator Charge Type (?)** <Empty> Set

**Charge Start Volt(V)** start: 40V 40 Set

**Charge End Volt(V)** stop: 40V 40 Set

**Generator**

---

**Generator Charge Type (?)** <Empty> Set

**Charge Start Volt(V)** start: 40V 40 Set

**Charge End Volt(V)** stop: 40V 40 Set

**Max. Generator Input Power(W) (?)** [0, 7370/65534] Set

**Generator Charge Battery Current(A) (?)** 0A [0, 110] Set

**Charge Start SOC(%)** start: 23% 23 Set

**Charge End SOC(%)** stop: 53% 53 Set

### Generator Start Conditions:

The generator will start when utility fails and one of the following conditions is met:

- The battery is discharged to the cut-off setting
- There is a force charge request from the battery
- The battery voltage or SOC is lower than the “Generator Charge Start Battery Volt/SOC” setting

### Generator Stop Conditions:

The generator will stop when the battery voltage or SOC is higher than the “Generator Charge End Battery Volt/SOC” settings.

## 2.8.5 Gen Boost Function

In real applications, customer loads often fluctuate, making generators highly sensitive to frequent changes. Activating GEN Boost can allocate a margin for the generator's input power, preventing it from consistently operating near overload conditions.

### Enable GEN boost

The screenshot shows a configuration page for the GEN Function. At the top, there is a green header with a dropdown arrow and the text 'GEN Function'. Below this, there are two tabs: 'Generator' (which is selected and highlighted with a green underline) and 'Smart Load'. The main content area contains several settings:

- Generator Boost:** A toggle switch with 'Enable' and 'Disable' buttons. The 'Enable' button is highlighted with a red rectangular box.
- Generator Charge Type (?):** A dropdown menu currently showing '<Empty>' and a 'Set' button.
- Charge Start Volt(V):** A slider control with 'start: 40V' on the left and a 'Set' button. The value '40' is displayed in a text box.
- Charge End Volt(V):** A slider control with 'stop: 40V' on the left and a 'Set' button. The value '40' is displayed in a text box.

## 2.9 Smart load Connection

The Eco Beast Pro's dedicated generator port can also connect to various smart loads, such as water heaters, in addition to generators.

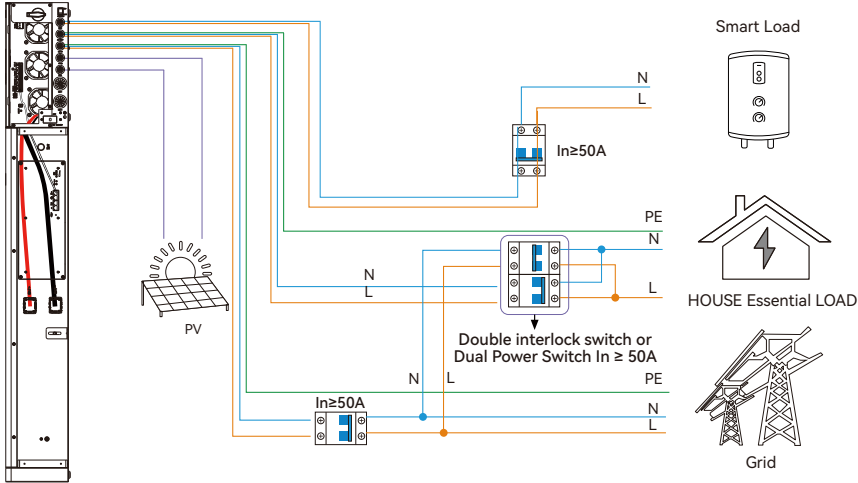

### 2.9.1 smart load settings

#### Enable Smart Load

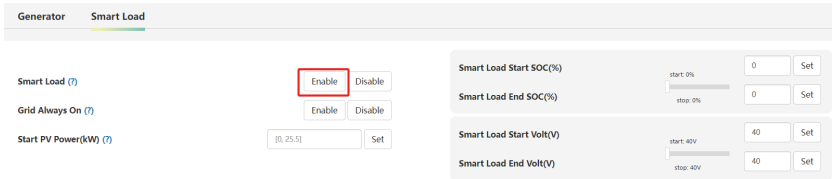

Enable “Grid always on”: When connected to the grid, the smart load remains continuously connected. Start PV Power: Input the PV power threshold at which you want the smart load to start. You can also input the battery's SOC or voltage to select when to start and stop.

If your home already has an existing grid-tied system, you can connect it to our generator interface as an AC power input, transforming your grid-tied system into an energy storage system.

## 2.10 AC Coupling Settings

The AC Coupling setting must be enabled when connecting an existing on-grid system to the GEN port.

- Start SOC(%): The SOC at which the AC-coupled inverters are turned on when in off-grid mode (50% to 70% recommended).
- End SOC(%): The SOC at which the AC-coupled inverters are shut down when in off-grid mode (90% recommended).

### Enable Ac Couple

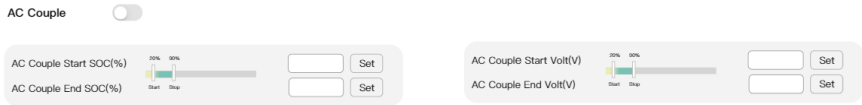

When on-grid and export to grid are enabled, the AC-coupled inverter will always be on, selling any extra power back to the grid. Ensure you are permitted to sell power to your utility provider when using AC-coupled PV arrays on-grid.

Note: It is recommended to keep the Start Volt/SOC and End Volt/SOC within 5%–10% of each other for optimal operation when utilizing the AC coupling function.

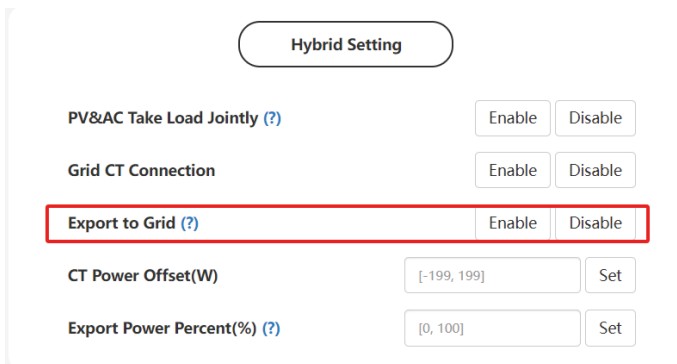

## 2.11 Parallel function

Eco Beast Pro 6500 inverter support up to 16 units to composed single phase parallel system or three phase parallel system, for parallel system setup

**Step1.** Cable connection: the system connection is as below:

**⚠ Cannot share PV input at any time!**

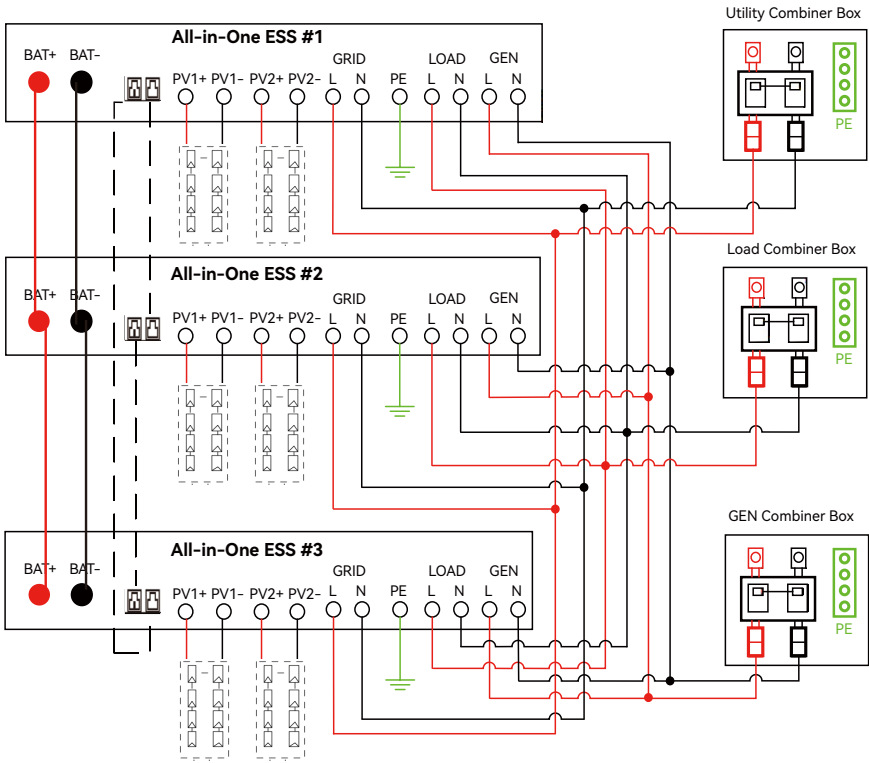

**⚠ Cannot share PV input at any time!**

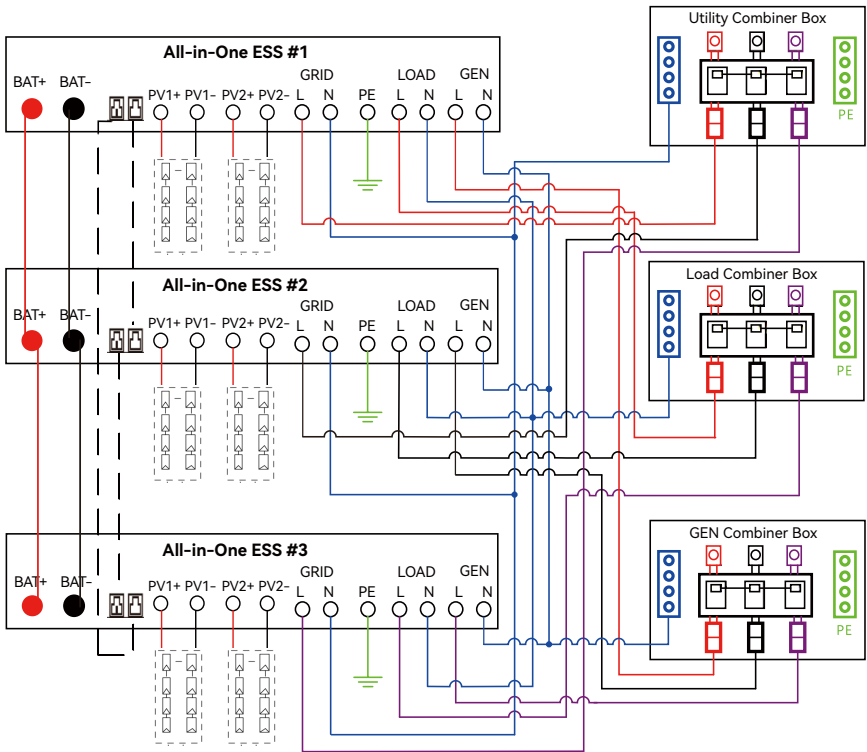

**Step2.** Please put the CAN communication PIN to on status for the first and the end inverter

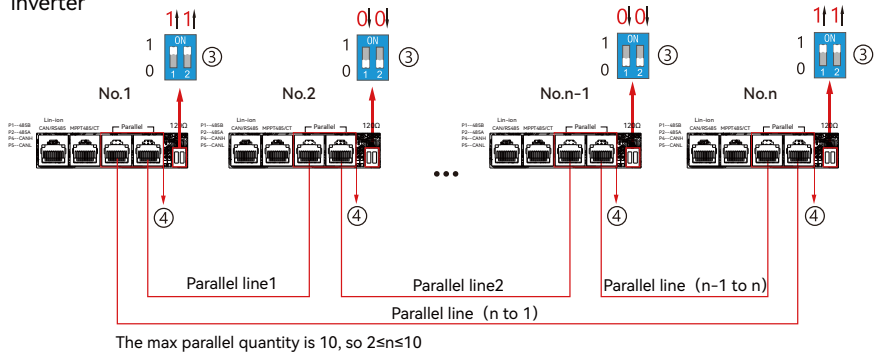

**Step3.** Setup the monitor for the system, add all datalogs in one station. Users can login to the visit interface of monitor system, Configuration->station->Plant Management->add datalog to add the datalogs.

Plant name	Installer	End User	Country	Timezone	Daylight saving time	Create date	Action
1 Genesis		Aspergo Install	South Africa	GMT+2	No	2019-03-14	Station Management
2 Butler Home	Elangeni	jhnbutler	South Africa	GMT+2	No	2019-03-25	Station Management
3 Office			South Africa	GMT+2	No	2019-06-03	Station Management
4 Cronje Home	Broomhead	cronje	South Africa	GMT+2	No	2019-07-16	Station Management

**Step4.** Enable share battery for the system if the system share one battery bank, otherwise disable the shared battery function

**Step5.** Set the system as a parallel group in the monitor system

Serial number	Status	Solar Power	Charge Power	Discharge Power	Load	Solar Yield	Battery Dischar	Feed Energy	ConsumptionEr	Station name	Parallel	Action
1 0272011008	Normal	228 W	42 W	0 W	182 W	215.3 kWh	99.4 kWh	0 kWh	551.2 kWh	Dragonview	A-1	Parallel
2 0272011011		35 W	32 W	0 W	0 W	158.7 kWh	21.1 kWh	0 kWh	160.5 kWh	Dragonview	A-2	Parallel
3 0272011012		1 kW	129 W	0 W	1 kW	170.3 kWh	49.9 kWh	0 kWh	434.5 kWh	Dragonview	A-3	Parallel
4 0272011017		79 W	48 W	0 W	106 W	99 kWh	85.4 kWh	0 kWh	257.1 kWh	Dragonview	A-4	Parallel

For more detailed guidance for paralleling system, please visit <https://www.luxpowertek.com/download/> And download the guidance

## 2.12 Power ON/OFF

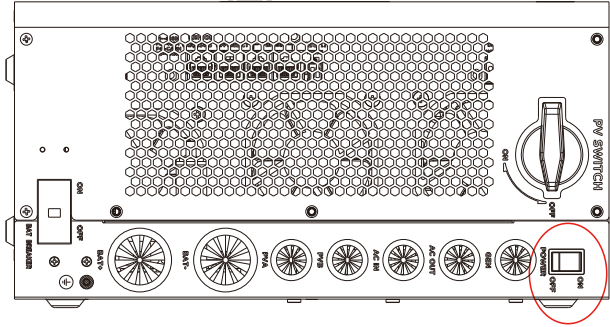







1. Power Switch: Controls the device power

After completing the connections, please turn on the power switch. In certain emergency situations, users can turn off the power switch to cut the power.

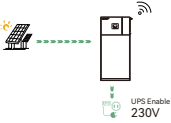
## 3. Working modes

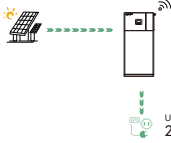
### 3.1 Eco Beast Pro 6500 modes introduction:

Bypass Mode		AC is used to take the load
PV Charge Bypass		PV charge the battery while the AC power the load
BAT Grid off		Battery is used to take the load
PV + BAT Grid off		PV + BAT power the load together

<p>PV Charge + Grid off</p>		<p>PV charge the battery and power the load</p>
<p>AC Charge</p>		<ol style="list-style-type: none"> <li>1. AC charge the battery from AC Input or GEN Input</li> <li>2. When the battery is power off, the AC can wake up the battery automatically</li> </ol>
<p>PV + AC charge</p>		<p>PV + AC charge the battery AC is from AC Input or GEN Input</p>
<p>PV Grid off</p>		<p>NOTE: The output power depends on the PV energy input, if the PV energy is unstable, witch will influence the output power</p>
		<p>When you power off the battery, the PV will supply power to the load.</p>
<p>PV charge Grid on</p>		<p>PV charge battery and power the load *The rest power from PV can feed in Grid</p>
<p>PV + BAT Grid on</p>		<p>PV + Battery power the load, and the AC can power the load if PV + Battery power not enough</p>
<p>PV Grid on</p>		<p>PV power the load, the rest power feed in Grid</p>

### 3.2 Working Modes related setting description

Situation	Setting 1	Setting 2	Setting 3	Working modes and Description
AC abnormal	NA	NA	NA	off grid inverter mode if $P_{Solar} \geq P_{load}$ , solar is used to take load and charge battery if $P_{Solar} < P_{load}$ , solar and battery take the load together, system will discharge until battery lower than the Cut Off Voltage/SOC
AC normal	PV&AC Take Load Jointly Enable	In the AC first time	NA	Hybrid Mode 1(charge first) Solar power will used to charge battery first, 1. The solar power will be used to charge the battery first. Ac will take load. 2. if solar power is higher than power need to charge the battery, the extra power will used to take load together with grid 3. If there is still more energy after charge battery and take the load, it will feed energy into grid if export to grid function is enabled
		Enable AC charge and in the AC charge time	AC charge according to time	Hybrid Mode 1(charge first)+AC charge battery if solar power is not enough to charge battery
			AC charge according to battery voltage or SOC	Hybrid Mode 1(charge first)+AC charge battery if solar power is not enough to charge battery and the battery voltage/SCO is lower than AC start charge voltage/SOC, the AC will stop charging when the battery Voltage/SOC is higher than AC end charge battery voltage/SOC
	Not in the AC first time and disable AC charge or not in the AC charge time	NA	Hybrid Mode 2(load first) Solar power will used to take load first, 1. if solar power is lower than load, battery will discharge together to take load until battery lower than EOD voltage/SOC 2. if solar power is higher than load, the extra power will used to charge battery, if there is still more energy, it will feed into grid if enable export	
	PV&AC Take Load Jointly Disable	In the AC first time	NA	Bypass Mode AC will take the load and Solar is used to charge battery
		AC charge according to SOC/Battery voltage	AC charge according to time	Bypass Mode+AC charge battery/Solar is used to charge battery AC will take load and also charge battery during AC charge time if solar power is not enough
AC charge according to SOC/battery voltage			Bypass Mode+AC charge battery Solar is used to charge battery AC will take load and also charge battery when battery SOC/Voltage is lower than start SOC /Voltage, and the AC will stop charging when the battery Voltage/SOC is higher than AC end charge battery voltage/SOC	
NA	NA	NA	off grid inverter mode if $p_{Solar} \geq p_{load}$ , solar is used to take load and charge battery if $p_{Solar} < p_{load}$ , solar and battery take the load together, system will discharge until battery lower than EOD Voltage/SOC	

### 3.3 Working as a hybrid inverter.

3.3.1. Eco Beast Pro 6500 can work as traditional off grid inverter or as a hybrid inverter. When PV and AC inputs are disabled and load is taken jointly, it functions as a traditional off-grid inverter; otherwise, it operates in hybrid mode. In this situation, inverter either use (solar + battery) to take load or use AC take load.

Related setting.

**Hybrid Setting**

<b>PV&amp;AC Take Load Jointly</b>	<input type="button" value="Enable"/>	<input type="button" value="Disable"/>
<b>Grid CT Connection</b>	<input type="button" value="Enable"/>	<input type="button" value="Disable"/>
<b>Export to Grid</b>	<input type="button" value="Enable"/>	<input type="button" value="Disable"/>
<b>CT Power Offset(W)</b>	<input type="text" value="[-199,199]"/>	<input type="button" value="Set"/>
<b>Export Power Percent(%)</b>	<input type="text" value="[0,100]"/>	<input type="button" value="Set"/>

3.3.2 AC First: During the setting time, system will use AC to take load, use solar power to charge the battery first. If there is extra solar power, extra solar power will take the load. When out of the setting time, system will use solar and battery to take load first until battery voltage/SOC is lower than On Grid EOD settings, then it will use AC to take the load.

	Start		End
<span style="background-color: #28a745; color: white; border-radius: 5px; padding: 2px 5px;">T1</span>	<input type="text" value="[0,23]"/> : <input type="text" value="[0,23]"/> <input type="button" value="Set"/>		<input type="text" value="[0,23]"/> : <input type="text" value="[0,23]"/> <input type="button" value="Set"/>
<span style="background-color: #17a2b8; color: white; border-radius: 5px; padding: 2px 5px;">T2</span>	<input type="text" value="[0,23]"/> : <input type="text" value="[0,23]"/> <input type="button" value="Set"/>		<input type="text" value="[0,23]"/> : <input type="text" value="[0,23]"/> <input type="button" value="Set"/>
<span style="background-color: #17a2b8; color: white; border-radius: 5px; padding: 2px 5px;">T3</span>	<input type="text" value="[0,23]"/> : <input type="text" value="[0,23]"/> <input type="button" value="Set"/>		<input type="text" value="[0,23]"/> : <input type="text" value="[0,23]"/> <input type="button" value="Set"/>

**Discharging**

Discharge Control

Discharge Current Limit(Adc)

Battery Warning Voltage(V)

Battery Warning SOC(%)

On-grid CutOff SOC(%)

Off-grid CutOff SOC(%)

On-grid Cut-Off Volt(V)

Off-grid Cut-Off Volt(V)

off-grid on-grid

off-grid on-grid

off-grid on-grid

off-grid on-grid

3.3.3 AC Charge function Disable: The system will not use AC to charge the battery (except Li-ion BMS set force charge flag)

AC Charge Battery Current(A)	[0,250]	Set
AC Charge Based On	<Empty>	Set

- <Empty>
- Disable
- Time(According to)
- Battery Voltage(According to)**
- Battery SOC(According to)
- Battery Voltage and Time(According to)
- Battery SOC and Time(According to)

- According to Time: During the setting time, system will use AC to charge the battery until battery full and battery will not discharge during the setting time.
- According to Battery Voltage: During the setting voltage, system will use AC to charge the battery if battery voltage is lower than AC Charge Start Battery Voltage and will stop when Voltage is higher than AC Charge End Battery Voltage.
- According to Battery SOC: During the setting SOC, system will use AC to charge the battery if battery SOC is lower than AC Charge Start Battery SOC and will stop when Voltage is higher than AC Charge End Battery SOC.
- According to Battery Voltage and Time: During the setting time, system will use AC to charge the battery if battery voltage is lower than AC Charge Start Battery Voltage and will stop when Voltage is higher than AC Charge End Battery Voltage. And battery will not discharge during the setting time.
- According to Battery SOC and Time: During the setting time, system will use AC to charge the battery if battery SOC is lower than AC Charge Start Battery SOC and will stop when Voltage is higher than AC Charge End Battery SOC. And battery will not discharge during the setting time.

## 4. LCD display and settings

### 4.1 LED Display

LED Indicator			Messages
1	Green	Solid On	Working normal
		Flashing	fast: Warning slow: Firmware update
2	Red	Flashing	Fault condition occurs in the inverter

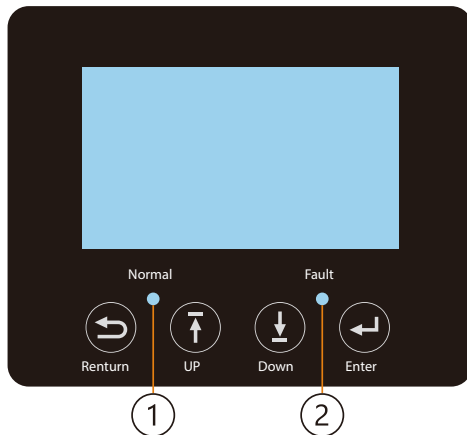

## 4.2 LCD Display

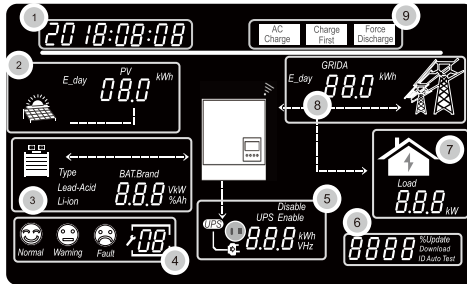

No.	Description	Remarks
1	Generally Information Display Area	Display the currently time/date by default (-year/month/day/hour/minute"switching automatically). When press Up or Down buttons, this area will display the firmware version information, serial number etc. Display the setting selection information when entering settings
2	On-grid solar inverter output power and energy data	This area shows the data of PV voltage, power and the setting of PV input connection information
3	Battery information and data	This area shows the battery type, battery brand (lithium battery), the lead-Acid battery setting of CV voltage, Floating charging voltage, Cut off voltage, Discharge end voltage. And display the voltage, SOC and power in turns of period of 1 seconds
4	System working status /setting code	There are three type of working status-normal, warning and fault, in right side of this area, there are code display, it will display different type of code -the system working mode code, warning code, fault code and setting code
5	UPS/EPs output information and data	When UPS function is enabled, this area will display UPS voltage, frequency, power etc. in turns of periods of 1s
6	Programming & the percentage of AC output power	When firmware updating in process, it will display relevant information When in grid off, this area will display the Percentage of the maximum AC output power
7	Loads consumption	Display the power consumption by the loads in on grid model
8	Grid information and Generator information	Display the grid (GRIDA) information of voltage, frequency, input or output power, the Generator (GRIDB) information of voltage, frequency, input power, switch period of 1s
9	Working mode settings area	When make settings on the Eco Beast Pro 6500 inverter through the LCD, this area will display the AC Charge, Force Discharge, Charge Firststop for setting on those working modes. It will not display those information unless in the setting process.

### 4.3 Inverter Status Display

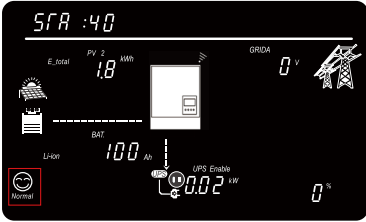
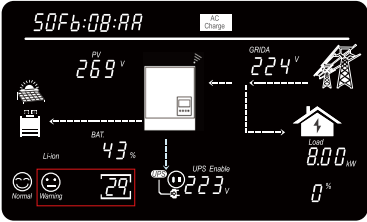
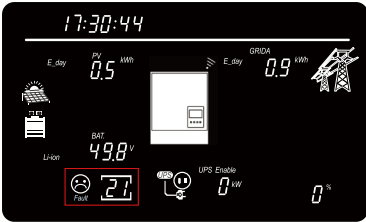
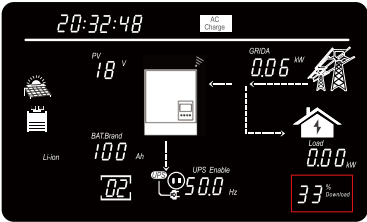
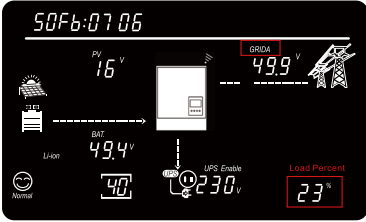
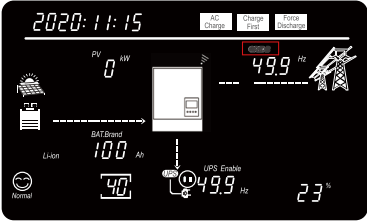
<p>Normal status, running status 40</p> 	<p>Warning Status, warning 29</p> 
<p>Fault status, fault 21</p> 	<p>Flash status: download percent is 33%</p> 
<p>When display 'GRIDA', it means the Grid information is about AC utility, The percent display on the right down corner means the load percentage.</p> 	<p>When display 'GRIDB', it means the AC information is about Gen set input.</p> 

### 4.4 LCD Settings

There are four buttons on the LCD.

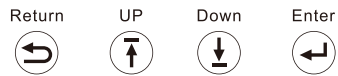

**Step for setting by the display:**

**Step 1.** After touch Enter button for about 2 seconds, the unit will enter setting mode. The setting icon and index will flashing.







**Step 2.** Touch UP or Down button to select setting index form 1 to 19.

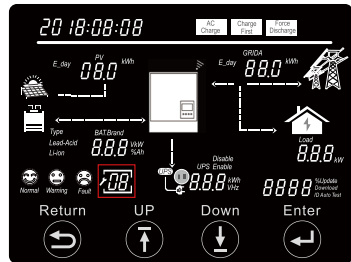

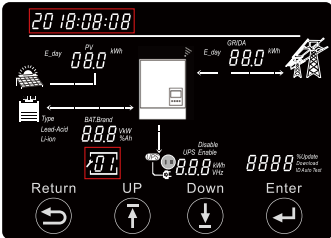

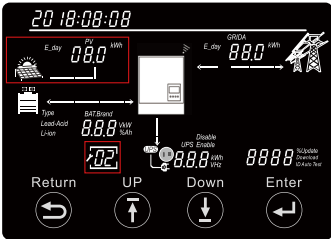

**Step 3.** Then touch Enter button to set this item.

**Step 4.** Touch UP or Down button to change the settings.



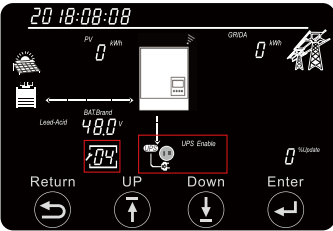

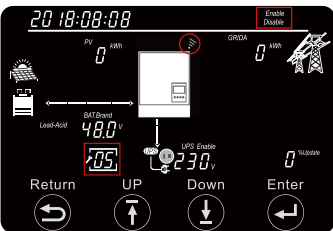
**Step 5.** Touch Enter to confirm the setting or Return the setting list is as below.

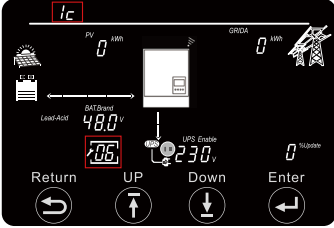
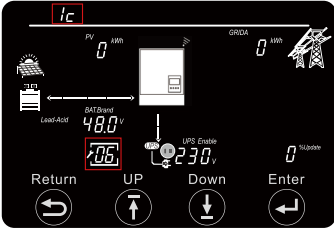
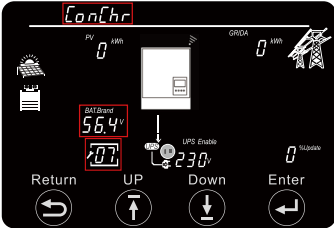

Index	Description	Setting Option
1	Date&time	 <p>Setting Year / Month / day</p>  <p>Setting hour / minute / second</p> 
2	PV input mode	 <p>Default: S S: two independent Strings input</p>  <p>P: Same string input for 2 MPPTs</p>  <p>dc: DC source input</p> 

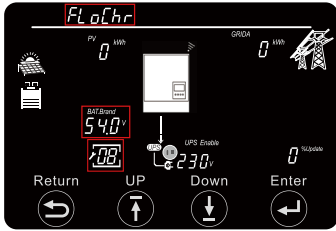

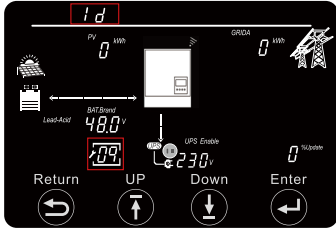
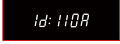
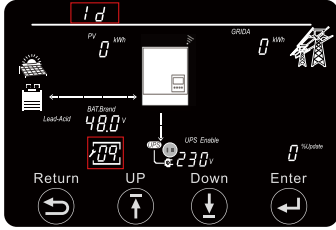
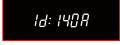
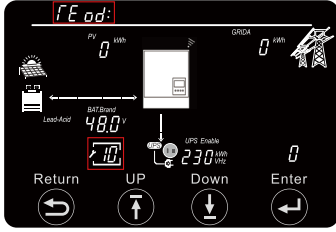
<p>3</p>	<p>Battery</p>	<p>Run with No Battery:  <b>Step 1.</b> Choose battery type first, when no flashing, select Enter to choose Run with No battery.</p>  <p>For Lead Acid:  <b>Step 1.</b> Choose battery type first, when Lead-Acid flashing, select Enter to choose Lead-acid battery.  <b>Step 2.</b> Then choose battery capacity.</p>  <p>For Lithium battery:  <b>Step 1.</b> Choose battery type first, when Li-ion flashing, select Enter to choose Li-ion battery  <b>Step 2.</b> Choose battery brand.          0- &gt; Standard Battery 2-&gt;Pylon Battery          6-&gt;Luxpower protocol Battery</p> 
<p>4</p>	<p>UPS Output voltage and frequency</p>	 <p>AC Output voltage          200Vac / 208Vac / 220Vac / 230Vac (Default) / 240Vac</p>  <p>AC Output frequency          50Hz (Default)/60Hz</p> 
<p>5</p>	<p>Buzzer enable</p>	 <p>Buzzer enable (Default)</p>  <p>Buzzer Disable</p> 

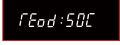
<p>6</p>	<p>Ic: Maximum charge current</p>	<p>MODEL: SNA5000WPV</p>  <p>Totoal charge current (Iac+I<sub>pv</sub>) setting Setting range: 0A~110A Default: 110A</p> <p><b>Ic: 110A</b></p> <p>AC charge current setting: Setting range: 0A~110A Default: 30A</p> <p><b>I2c: 30A</b></p> <p>Generator charge current setting: Setting range: 0A~60A Default: 30A</p> <p><b>I9c: 30A</b></p>
<p>7</p>	<p>ConChr: CV voltage setting (Only in Lead-acid battery type)</p>	<p>MODEL: SNA6500WPV</p>  <p>Totoal charge current (Iac+I<sub>pv</sub>) setting Setting range: 0A~140A Default: 140A</p> <p><b>Ic: 140A</b></p> <p>AC charge current setting: Setting range: 0A~140A Default: 30A</p> <p><b>I2c: 30A</b></p> <p>Generator charge current setting: Setting range: 0A~110A Default: 30A</p> <p><b>I9c: 30A</b></p>
		<p>ConChr: CV voltage setting (Only in Lead-acid battery type)</p>  <p>Setting range: 50.0~59.0Vdc Default: 56.4V</p> <p><b>ConChr: 56.4V</b></p>

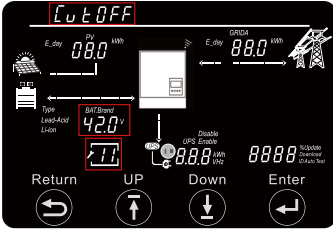
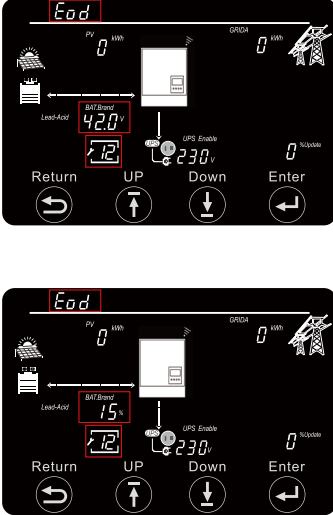
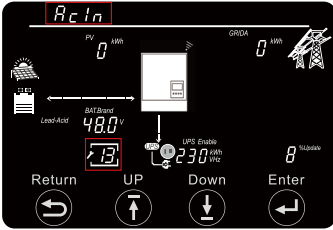
<p>8</p>	<p>FloChr: Floating charging voltage setting (Only in Lead-acid battery type)</p>	 <p>Setting range: 50.0~56.0Vdc Default: 54.0V</p> 
<p>9</p>	<p>Id: Maximum discharge current</p>	<p>MODEL: SNA5000WPV</p>  <p>Totoal discharge current setting Setting range: 0A~110A Default: 110A</p>  <p>MODEL: SNA6500WPV</p>  <p>Totoal discharge current setting Setting range: 0A~140A Default: 140A</p> 
<p>10</p>	<p>TEOd: Discharge control type: VOLT / SOC</p>	 <p>Setting Range: VOLT / SOC</p>  

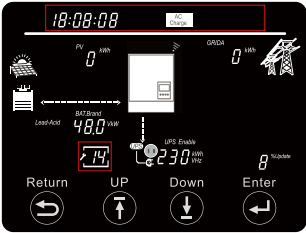
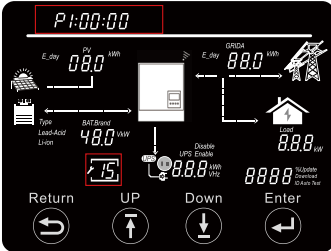
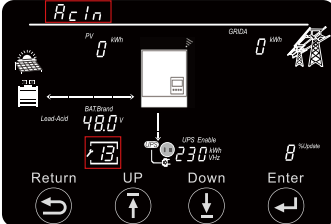
<p>11</p>	<p>CutOFF: Cut off Voltage or SOC, depend on TEOd</p>		<p>Setting range: VOLT: 40.0-OnGrid EOD Volt Default:42V</p> <p>SOC: 0-OnGrid EOD SOC Default: 15%</p>
<p>12</p>	<p>Eod: Discharge end voltage or soc with grid, depend on TEOd</p>		<p>Setting range: VOLT: Cut off Volt-58V Default: 42V</p> <p>SOC: Cut off SOC-90 Default: 15%</p>
<p>13</p>	<p>AcIn: AC voltage range setting</p>		<p>Unity AC Input voltage range: 90Vac~280Vac</p> <p>Unity AC Input voltage range: 170Vac~280Vac</p>

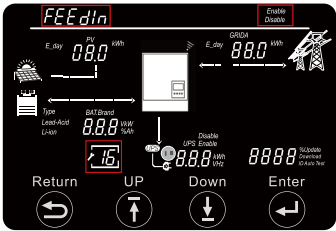
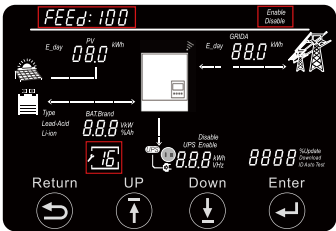

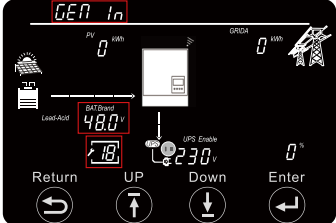
	<p>AC charge setting (The setting process must enable the AC charging function, confirm the full battery SOC value, and set the confirmation time period 1, 2, 3 to truly complete the AC charging function setting)</p>		<p>AC Charge function: Setting range: 1. DIS: AC charge disable; 2. TIM: According to time; 3. VOL: According to battery voltage; 4. SOC: According to battery soc; (Touch “Enter” button to set ac charge parameter )</p> <p style="text-align: center;"><b>AcCh: d15</b></p>
<p>14</p>	<p>AC charge control: Setting range: Vol: 1. Start Voltage: 35.4~52V; 2. End Voltage: 48~59V; SOC: 1. Start Soc: 1~90%; 2. End Soc: 20~100%;</p> <p style="text-align: center;"><b>AcCh: UDL</b> <small>start</small></p> <p style="text-align: center;"><b>T 2.0 v</b>      <b>BAT 15 %</b></p>	<p>Setting AC Charge time of 1 start: Range: 00:00~23:59 Default: 00:00~00:00</p> <p style="text-align: center;"><b>P1:00:00</b> <small>start</small></p> <p>Setting AC Charge time of 1 end: Range: 00:00~23:59 Default: 00:00~00:00</p> <p style="text-align: center;"><b>P1:23:59</b> <small>end</small></p> <p>Similar to set time2 and times</p> <p style="text-align: center;"><b>P2:00:00</b> <small>start</small></p> <p style="text-align: center;"><b>P3:00:00</b> <small>start</small></p>	
<p>15</p>	<p>Utility source (AC Input) to take Load time setting</p>		<p>Setting time of 1 start: Range: 00:00~23:59 Default: 00:00~00:00</p> <p style="text-align: center;"><b>P1:00:00</b> <small>start</small></p> <p>Setting time of 1 end: Range: 00:00~23:59 Default: 00:00~00:00</p> <p style="text-align: center;"><b>P1:23:59</b> <small>end</small></p> <p>Similar to set time2 and time3</p> <p style="text-align: center;"><b>P2:00:00</b> <small>start</small></p> <p style="text-align: center;"><b>P3:00:00</b> <small>start</small></p>
<p>16</p>	<p>Hybrid enable / disable</p>		<p>Setting Range: Hybrid Disable (default)</p> <p style="text-align: center;"><b>Disable</b></p> <p>Hybrid Enable</p> <p style="text-align: center;"><b>Enable</b></p>

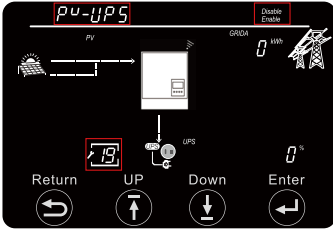
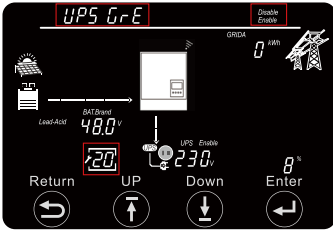
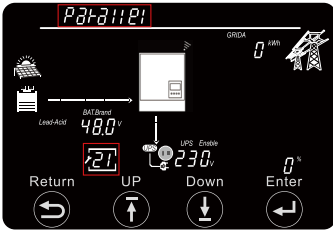
	<p>Feed-In Enable / disable Only valid when Hybrid is enabled</p>		<p>Setting Range: Feed-In Disable (default)</p> <p><b>Disable</b></p> <p>Feed-In Enable</p> <p><b>Enable</b></p>
<p>16</p>	<p>Maximum Feed-In percent Only valid when Feed-In is enabled Power percent can be set larger than 100% in case of there is other generating device in the system</p>		<p>Setting Range: 0-100% 0% (default)</p> <p><b>FEED: 100</b></p>
<p>17</p>	<p>Battery Wakeup Enable / disable (Not for No Battery type)</p>		<p>Enable wakeup battery</p>
<p>18</p>	<p>Max Generator Input Power</p>		<p>Setting Range: 0-7369W 7369W (default)</p> <p><b>GEN: 7369</b></p>

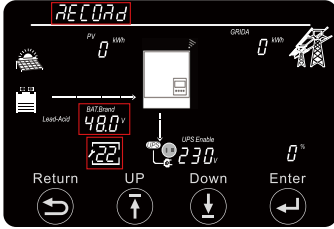
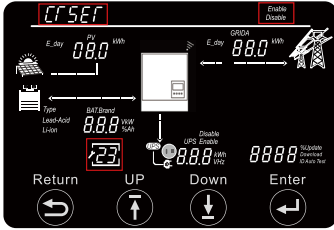
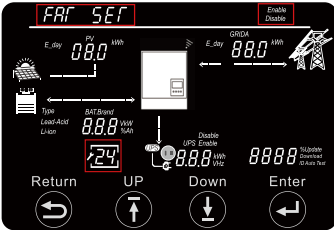
<p>19</p>	<p>PV Off Grid enable / disable</p>		<p>Setting Range: PV Off Grid Enable (default)</p> <p><b>Enable</b></p> <p>PV Off Grid Disable</p> <p><b>Disable</b></p>
<p>20</p>	<p>Power Save Function enable / disable</p>	 <p>Setting Range: ECO Mode Disable (default)</p> <p>ECO Mode Enable</p> <p><b>Disable</b>      <b>Enable</b>      <b>Enable</b></p>	<p>Setting Range: Green Function Disable (default)</p> <p><b>Disable</b></p> <p>Green Function Enable: When enabled, if the inverter load reading is less than 60W for more than 0minutes, the inverter output will be cut off.</p>
<p>21</p>	<p>Parallel setting</p>	 <p>Parallel phase setting Setting Range: P1 ( Rphase) / P2 (Sphase) / P3 (Tphase) P1 (default)</p> <p><b>P4R5:P1</b></p>	<p>Parallel type setting Setting Range: NoPL (not Parallel) / 1PH (Single phase) / 3PH (Three phase) NoPL (default)</p> <p><b>P2:P3:1PH</b></p> <p>Bat Share enable / disable Setting Range: Disable (default) Enable</p> <p><b>826542P</b>      <b>Disable Enable</b></p>

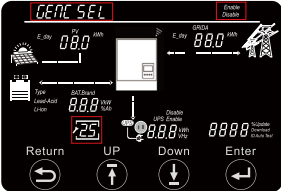
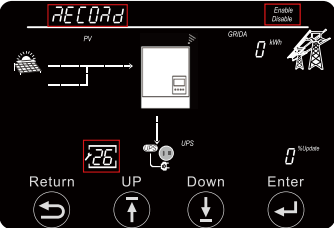
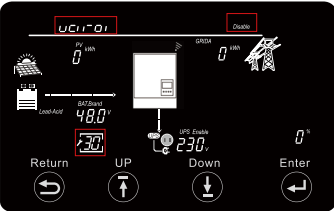
<p>22</p>	<p>Error / Alarm Record</p>		<p>Error Record                  -&gt;Record Index                  -&gt;&gt;Record Msg:                  (Year: Month: Day;                  Hour: Min:Sec; Error code)</p> <p><b>Err REC</b></p> <p>Alarm Record-&gt;Record Index-&gt;&gt;Record Msg:                  (Year: Month:Day; Hour: Min: Sec; Alarm code)</p> <p><b>ALB REC</b></p>
<p>23</p>	<p>CT Offset</p>		<p>External Grid CT                  (Latest Version Only)                  Setting Range:                  Disable (default) / Enable</p> <p><b>CF-EH</b> <span>Disable</span> <span>Enable</span></p> <p>Internal CT Offset                  Setting Range: -200~200W                  20W (default)</p> <p><b>CF</b> <b>-169</b> <span>Power</span></p>
<p>24</p>	<p>Fan speed setting</p>	 <p>Fan2 Speed Percent                  Setting Range: 20-100%                  70% (default)</p> <p><b>FAN</b> <b>055</b></p>	<p>Fan1 Speed Percent                  Setting Range: 20-100%                  70% (default)</p> <p><b>FAN</b> <b>055</b></p> <p>Fan1 Speed New Slope                  Setting Range:                  Disable (default) Enable</p> <p><b>FAN SL OP</b> <span>Enable</span> <span>Disable</span></p> <p>Fan1 Speed New Slope Setting Range:                  Disable (default)                  Enable</p> <p><b>FAN SL OP</b> <span>Enable</span> <span>Disable</span></p>

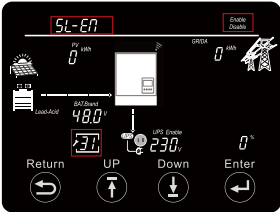
<p>25</p>	<p>Generator charge setting</p>	 <p>Generator charge setting -&gt;charge control type Setting Range: 1. VOL (default) 2. SOC</p> <p>Return UP Down Enter</p> <p>GENE VOL GENE 50</p> <p>-&gt;control type -&gt;&gt;control value Setting Range: VOL : 1. Start Voltage: 38.4-52V; 2. End Voltage: 48-59V; SOC: 1. Start Soc: 1-90%; 2. End Soc: 20-100%;</p> <p>GENE VOL Start</p> <p>BAT 42.0 V BAT 15 %</p>
<p>26</p>	<p>Neutral-Ground Bonding Function</p>	 <p>This setting allows the user to enable or disable the internal neutral-ground bond. The inverter must be in standby to make this change. Turn the “EPS Output” switch to off to engage standby mode. Range: Enable / Disable Default: Enable</p> <p>Return UP Down Enter</p> <p>Enable</p> <p>Disable</p>
<p>30</p>	<p>GEN BOOST Enable/Disable</p>	 <p>GEN BOOST -&gt;Enable/Disable Setting Range: 1. Disable (default) 2. Enable</p> <p>Return UP Down Enter</p> <p>Enable</p> <p>Disable</p>

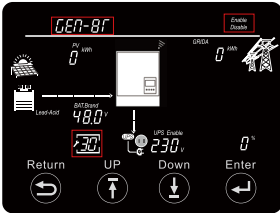
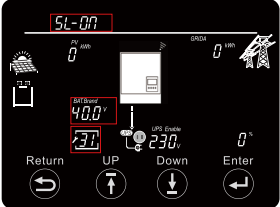
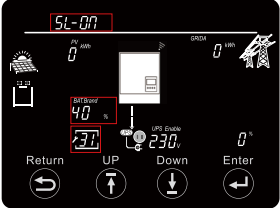
		
		<p>Smart Load -&gt;Enable/Disable Setting Range: 1. Disable (default) 2. Enable</p> <div style="display: flex; justify-content: space-around; margin-top: 10px;"> <div style="border: 1px solid black; padding: 5px 15px; background-color: #333; color: white;">Enable</div> <div style="border: 1px solid black; padding: 5px 15px; background-color: #333; color: white;">Disable</div> </div>
		<p>-&gt;&gt;Smart Load GridOn Setting Range: 1. Disable (default) 2. Enable</p> <div style="text-align: right; margin-top: 10px;">  </div>
<p>31</p>	<p>Smart Load Enable/Disable</p>	<p>-&gt;&gt;&gt;Smart Load PV Power Setting Range: 0~25.5kW; (0.5kW default)</p> <div style="text-align: right; margin-top: 10px;">  </div>
		<p>-&gt;&gt;&gt;&gt;Smart Load On Volt/Soc Setting Range: VOL: 40~59V; (54V default) SOC: 0~100%; (90% default)</p> <div style="display: flex; flex-direction: column; align-items: right; margin-top: 10px;">   </div>

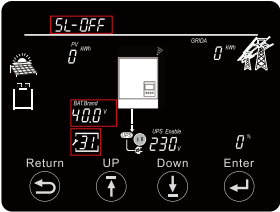
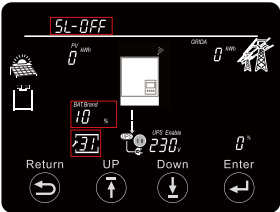
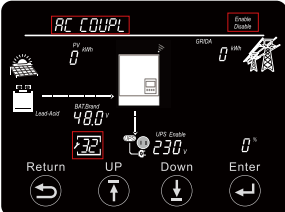
		<p>-&gt;&gt;&gt;&gt;&gt;Smart Load Off          Volt/Soc          Setting Range:          VOL: 40~59V; (48V default)          SOC: 0~100%; (60% default)</p>  
<p>32</p>	<p>AC Couple          Enable/Disable</p>	
		<div style="display: flex; justify-content: space-around; align-items: center;"> <div style="border: 1px solid black; padding: 5px; background-color: black; color: white; text-align: center;">Enable</div> <div style="border: 1px solid black; padding: 5px; background-color: black; color: white; text-align: center;">Disable</div> </div> <p>AC Couple          -&gt;Enable/Disable          Setting Range:          1. Disable (default)          2. Enable</p>

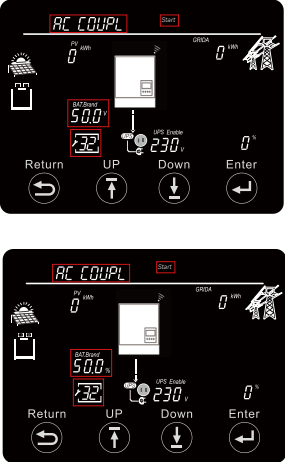
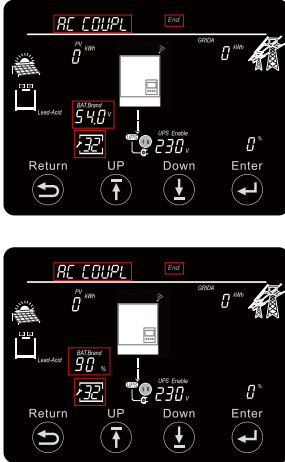
		<p>-&gt;&gt;AC couple Start Volt/Soc Setting Range: VOL: 40~59V; (50V default) SOC: 0~101%; (50% default)</p>  <p>The first screenshot shows the 'Start' menu with 'Start Volt' set to 50.0V and 'Start Soc' set to 50%. The second screenshot shows the 'Start Soc' menu with 'Start Soc' set to 50%.</p>
		<p>-&gt;&gt;&gt; AC couple End Volt/Soc Setting Range: VOL: 40~59V; (54V default) SOC: 0~101%; (90% default)</p>  <p>The first screenshot shows the 'End' menu with 'End Volt' set to 54.0V and 'End Soc' set to 90%. The second screenshot shows the 'End Soc' menu with 'End Soc' set to 90%.</p>

<p>34</p>	<p>Bat Warning Value Setting Volt/SOC</p>		
		<p>-&gt;Setting range:          VOL: CutOFF Volt-56.0V          Default: 44V          SOC: CutOFF SOC-100%          Default: 20%</p>	
		<p>-&gt;&gt;Bat low Buzzer Enable:          When enabled, the battery low warning will trigger the buzzer.</p>	

<p>35</p>	<p>Power input limit of the power grid</p>	<div data-bbox="369 220 819 513" data-label="Image"> </div> <div data-bbox="371 675 605 836" data-label="Text"> <p>-&gt;Setting range: 1~999 (unit: 0.1Kw) Default: 3K Power level: 4.8Kw 5K Power level: 8.0Kw other Power levels: 9.0Kw Parallel mode: 999Kw</p> </div> <div data-bbox="728 715 963 849" data-label="Image"> </div>
<p>36</p>	<p>System stop Charge Volt/SOC</p>	<div data-bbox="371 1031 804 1276" data-label="Image"> </div> <div data-bbox="394 1326 571 1420" data-label="Text"> <p>-&gt;Setting Volt value range: 40.0-59.5Vdc Default: 59.5V</p> </div> <div data-bbox="680 1299 929 1449" data-label="Image"> </div>

		<p>-&gt;Setting SOC value range: 10%-101% Default: 101%</p>	
37	PV charge first limited Volt/SOC	<p>-&gt;Setting range: 40.0-59.5Vdc Default: 59.5V</p>	
		<p>-&gt;Setting range: 10%-101% Default: 101%</p>	

## 5. Eco Beast Pro Inverter Monitoring System

Users can monitor the system via App and Web, App name is “LuxCloud”, monitoring website: server.luxpowertek.com

We will use the LuxCloud App as an example. Please follow the steps below to download the app, register your account, and connect your device.

**1. Download and install the “LuxCloud” App.** QR codes for Android and iOS downloads are shown below.



Android



iOS

### Registration Note:

When registering a Monitor account, if you are an end user, please request the Installer Code from your device provider (installer or distributor). You may also ask your device provider to help you complete the account registration directly.

**2. Check Device Status.** After the system is properly connected, power on the device. After the inverter powers on and the home screen is displayed, use the UP or DOWN button to scroll through the information pages. Navigate to the WiFi status screen, as shown below.

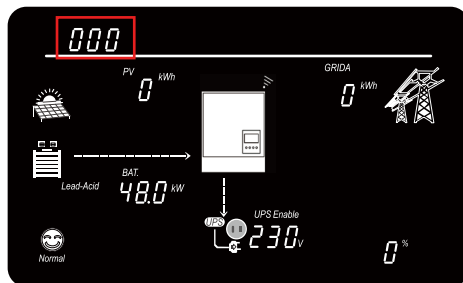

WiFi Connection Status: WIFI, SERVER, and INV (From right to left).

**3. Connect the dongle** after the WiFi indicator in the above interface changes to 1 or begins flashing.

a. Log in and Create a Plant

Log into your App account. Tap “**Create Plant**”, allow location permission when prompted, fill in the basic plant information, and save.

### Create a Plant

- 1). Tap Create Plant to create a new site.
- 2). Allow the App to access your location information (optional).
- 3). Fill in your personal information.
- 4). Complete the plant creation and proceed to Dongle matching.

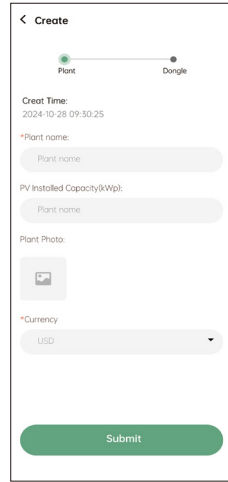
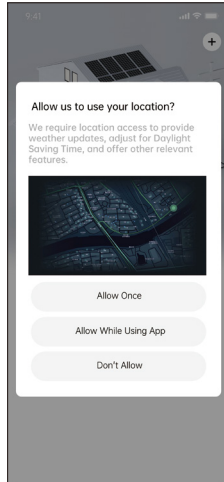
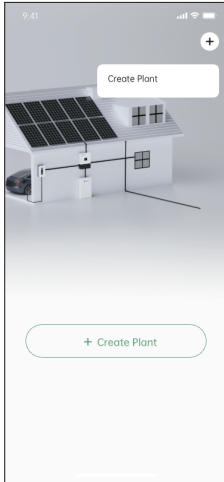

**b.** In the pop-up window, tap **Next**. Turn on your phone's Bluetooth and tap **Add by Bluetooth**. (Recommended: Connect via Bluetooth)

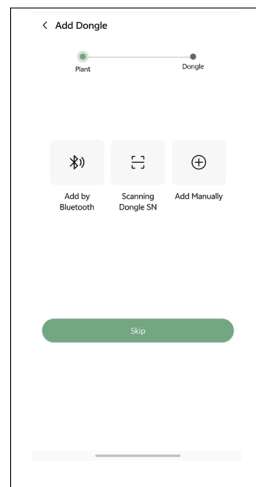
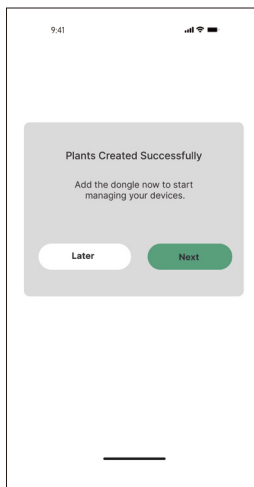

c. Select the serial number that matches the one on the device sticker and tap **Next**.

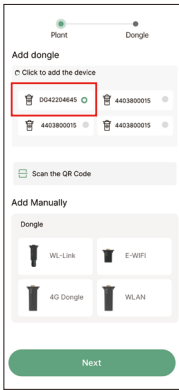

d. On the next screen, select your home Wi-Fi network, enter the Wi-Fi password, and tap **Save**. The dongle will reboot automatically. After completing the configuration, tap **Done**.

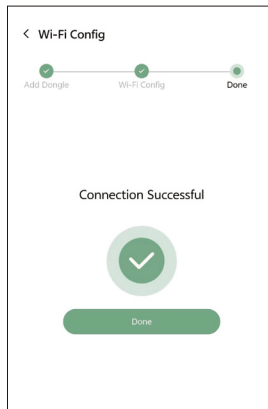
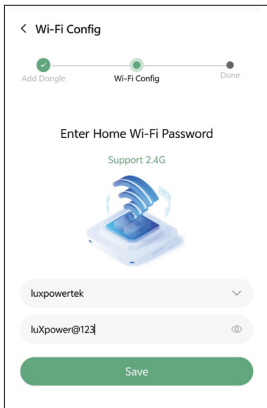

e. After the connecting, the indicator on the LCD will change to 1. The inverter is successfully online when all three connection statuses display 1.

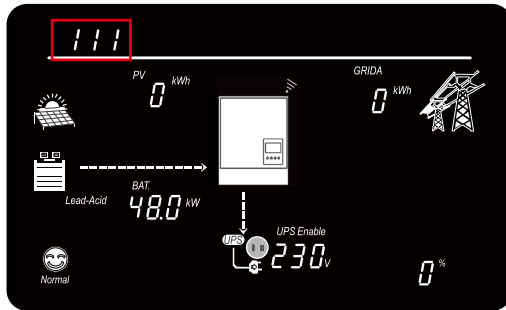

### Status Code Description

Status Code Indicator	Presentation of LED State
WiFi Status Code	Communication between dongle and Home WiFi
Cloud Icon Status Code	Communication between dongle and network
INV Status Code	Communication between dongle and inverter

### Status Code Explanation

Status Code (0/1)	Working Status	Troubleshooting
All status code: 1	Communication normal	-
WiFi status code: 0	Failure to connect to router	1. Check if the router is successfully connected 2. Verify that the home WiFi name and password are correct
Cloud Icon status code: 0	Internet connection failure	Verify if the router is working properly
INV status code: 0	Communication failure between dongle and inverter	Check and ensure the connection between dongle and inverter is secure

### Note:

The dongle status is updated every 30 seconds.  
The WIFI reset button can be used to reset or reboot the data logger (press for 5–10 seconds to reboot; press for more than 10 seconds to reset).

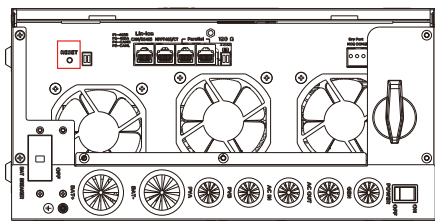

## 6. Specifications

Table 1 MPPT Mode Specifications	
<b>INVERTER MODEL</b>	Eco Beast Pro 6500
Max. PV Array Power (W)	9600(4800/4800)
Rated PV Input Voltage (V)	320
Number of Independent MPPT Inputs	2
PV Input Voltage Range (V)	100~500
MPPT Voltage Range (V)	120~440
Start-up Voltage (V)	100
Max. PV Input Current per MPPT (A)	17/17
Max. PV Short-circuit Current per MPPT (A)	25/25
Max. PV Charging Current (A)	140
Table 2 Battery Mode Specifications	
<b>INVERTER MODEL</b>	Eco Beast Pro 6500
Output Voltage Waveform	Pure Sine Wave
Output Voltage Regulation	208Vac/220Vac/230Vac/240Vac±5%
Output Frequency	50Hz/60Hz
Rated Output Power (W)	6500
Rated Output Current (A)	28.3
Max. Charging/Discharging Current (A)	140/140
Max. Charging/Discharging Power (W)	6500
Peak Efficiency	93%
Overload Protection	5s@≥150% load; 10s@110%~150% load
Surge Capacity	2*rated power within 5 seconds
Recommend Capacity of Battery per Inverter	>200AH
Battery Voltage Range	46.4V~60V(Li)    38.4V~60V(Lead_Acid)
High DC Cut-off Voltage	59VDC(Li)    60VDC(Lead_Acid)
High DC Recovery Voltage	57.4VDC(Li)    58VDC(Lead_Acid)

Low DC Warning Voltage(Lead Acid)	load < 20%	44.0Vdc(Settable)
	20% ≤ load < 50%	Warning Voltage @load<20% -1.2V
	load ≥ 50%	Warning Voltage @load<20% -3.6V
Low DC Warning Return Voltage		Low DC Warning Voltage@Different load +2V
Low DC Cut-off Voltage(Lead Acid)	load < 20%	42.0Vdc(Settable)
	20% ≤ load < 50%	Cut-off Voltage @load < 20% -1.2V
	load ≥ 50%	Cut-off Voltage @load < 20% -3.6V
Low DC Cut-off Return Voltage(Lead Acid)	Cut-off Voltage @load<20%≥45V	Low DC Cut-off Voltage @load<20%+3V
	Cut-off Voltage @load<20%<45V	48V
Low DC Warning SOC		20% SOC ( Settable )
Low DC Warning Return SOC		Low DC Warning SOC +10%
Low DC Cut-off SOC	15% SOC (Grid on) ( settable)	
	15% SOC (Grid off) ( settable)	
Low DC Cut-off Return SOC		Low DC Cut-off SOC +10%
Charge Cut-off Voltage		58.4Vdc
No Load Power Consumption		<60W
Lead_Acid Battery Charging Algorithm		3-Step
Absorption Charging Voltage	Flooded Battery	58.4Vdc (Recommend)
	AGM / Gel Battery	56.4Vdc (Recommend)
Floating Charging Voltage		54Vdc
<p>Charging Curve</p> <p>The graph illustrates the three-stage charging process for a lead-acid battery. The y-axis represents Battery Voltage (per cell) and Charging Current, with a 50% and 100% scale for current. The x-axis represents Time. The Bulk phase (Constant Current) shows a linear increase in voltage and constant current. The Absorption phase (Constant Voltage) shows a constant voltage and a decaying current. The Maintenance phase (Floating) shows a slightly lower constant voltage and a very low, stable current. Time points T0 and T1 are indicated on the x-axis, with T1 being the end of the absorption phase.</p>		

Table 3 AC Mode Specifications	
<b>INVERTER MODEL</b>	Eco Beast Pro 6500
Input Voltage Wave for	Sinusoidal(utility or generator)
Nominal Input Voltage(V)	230Vac
Low Loss Voltage	170Vac±7V(UPS); 90Vac±7V(Appliances)
Low Loss Return Voltage	180Vac±7V(UPS); 100Vac±7V(Appliances)
High Loss Voltage	280Vac±7V
High Loss Return Voltage	270Vac±7V
Max.AC Input Voltage	280Vac
Nominal Input Frequency	50Hz/60Hz(Auto detection)
Max.AC Input Current(A)	39.5
Max.AC Input Power(W)	9000
Max.AC Charging Current(A)	140
Rated AC Output Current(A)	28.3
Rated AC Output Power(W)	6500
Output Short Circuit Protection	Software Protect when GridOff Discharge Circuit Breaker Protect when GridOn Bypass
Transfer Time	<7ms @Single; <20ms @Parallel
Output powerderating: When AC input voltage drops to 200V, the output power will be derated.	Maxinv current: 30A Max inv power: 6.5kW

Table 4 Generator Mode Specifications

<b>INVERTER MODEL</b>	Eco Beast Pro 6500
Rated GEN Voltage(V)	230
Rated GEN Frequency(Hz)	50/60
Rated GEN Input Current(A)	32
Rated GEN Input Power(W)	7370

Table 5 Protection/General Specifications

<b>INVERTER MODEL</b>	Eco Beast Pro 6500
OverCurrent/Voltage Protection	YES
Grid Monitoring	YES
AC Surge Protection Type III	YES
Safety Certification	NRS 097, CE
Ingress Protection Rating	IP 20
Display & Communication Interface	LCD+LED, RS485/WIFI/CAN(Built-in)
Warranty	2 Years
Cooling Method	FAN
Topology	Transformer-less
Noise Emission(typical)	<50dB
Operating Temperature Range	0°C to 45°C(fullload)
Storage temperature	-15°C ~ 60°C
Humidity	5% to 95% Relative Humidity(Non-condensing)
Altitude	<2000m
Dimension(D*W*H)mm	580*350*175
Net Weight	98KG

## 7. Trouble shooting & Error List

Code	Description	Trouble shooting
E000	Internal communication fault1	Restart inverter, if the error still exist, contact us (DSP&M3)
E002	Bat On Mos Fail	Restart inverter, if the error still exist, contact us
E003	CT Fail	
E008	CAN communication error in Parallel System	Check CAN cable connection is connected to the right COM port
E009	No master in parallel system	Check parallel setting for master/Slave part, there should be one master in the system
E012	UPS output short circuit	Check if the load is short circuit, try to turn off the load and restart inverter
E013	UPS reserve current	Restart inverter, if the error still exist, contact us
E015	Phase Error in three phase parallel system	Check if the AC connection is right for three phase system, there should one at least one inverter in each phase
E016	Relay fault	Restart inverter, if the error still exist, contact us
E017	Internal communication fault2	Restart inverter, if the error still exist, contact us (DSP&M8)
E018	Internal communication fault3	Restart inverter, if the error still exist, contact us (DSP&M3)
E019	Bus voltage high	Check if PV input voltage is higher than 480V
E020	EPS connection fault	Check if EPS and AC connection is in wrong terminal
E021	PV voltage high	Check PV input connection and if PV input voltage is higher than 480V
E022	Over current internal	Restart inverter, if the error still exist, contact us
E024	PV short	Check PV connection
E025	Temperature over range	The internal temperature of inverter is too high, turn off the inverter for 10minutes, restart the inverter, if the error still exist, contact us
E026	Internal Fault	Restart inverter, if the error still existcontact us (Bus sample)
E028	Sync signal lost in parallel system	Check CAN cable connection is connected to the right COM port
E029	Sync trigger signal lost in parallel system	
E031	Internal communication fault4	Restart inverter, if the error still exist, contact us (DSP&M8)

W000	Communication failure with battery	Check if you have choose the right battery brand and communication cable is right, if the warning still exist, contact us
W003	Communication failure with meter	Check communication cable, if the warning still exist, contact us
W004	Battery failure	Inverter get battery fault info from battery BMS, restart battery, if the warning still exist, contact us or battery manufacture
W008	Software mismatch	Please contact Luxpower for firmware update
W009	Fan Stuck	Check if the fan is OK
W012	Bat On Mos	Restart inverter, if the error still exist, contact us
W013	Over temperature	The temperature is a little bit high inside inverter
W015	Bat Reverse	Check the battery connection with inverter is right, if the warning still exist, contact us
W018	AC Frequency out of range	Check AC frequency is in range
W019	AC inconsistent in parallel system2	Reconnect the AC input or Restart inverter, if the error still exist, contact us
W025	Battery voltage high	Check if battery voltage is in normal range
W026	Battery voltage low	Check if battery voltage is in normal range, need to charge the battery if battery voltage is low
W027	Battery open	Check if there is output from the battery and battery connection with inverter is OK
W028	EPS Over load	Check if EPS load is too high
W029	EPS voltage high	Restart inverter, if the error still exist, contact us
W031	EPS DCV high	Restart inverter, if the error still exist, contact us





# ■ YOUR RELIABLE ENERGY SOLUTION PARTNER



Lux Power Technology Co., Ltd  
Headquarter: +86 755 8520 9056  
www.luxpowertek.com  
Contact us: info@luxpowertek.com



092.20167AA