

TEST REPORT

Product Name : Energy Storage Inverter
Model Number : SNA PRO-EU 3K, SNA PRO-EU 4K,
SNA PRO-EU 5K, SNA PRO-EU 6K,
SNA PRO-EU 6.5K

Prepared for : Shenzhen Lux Power technology Co., LTD
Address : C501, Building A, Donghua Industrial Park, 5003 Bao'an Avenue, Sanwei Community, Hangcheng Street, Bao'an District, Shenzhen, 518126, China

Prepared by : EMTEK (SHENZHEN) CO., LTD.
Address : Building 69, Majialong Industry Zone, Nanshan District, Shenzhen, Guangdong, China

Tel: (0755) 26954280
Fax: (0755) 26954282

Report Number : ENS2511120219E00101R
Date of Test : November 01, 2025 to November 17, 2025
Date of Report : December 15, 2025



TABLE OF CONTENT

Test Report Description	Page
1. SUMMARY OF TEST RESULT	5
2. GENERAL INFORMATION	6
2.1. Description of Device (EUT).....	6
2.2. Independent Operation Modes	6
2.3. Test Manner	6
2.4. Description of Test Facility	7
2.5. Measurement Uncertainty	7
3. MEASURING DEVICE AND TEST EQUIPMENT	8
3.1. For Power Line Conducted Emission Measurement	8
3.2. For Voltage Distortion in Differential mode Measurement	8
3.3. For Radiated Emission Measurement	8
4. POWER LINE CONDUCTED EMISSION MEASUREMENT	9
4.1. Block Diagram of Test Setup	9
4.2. Measuring Standard	9
4.3. Power Line Conducted Emission Limits (Group 1 Class A)	9
4.4. Test Procedure	10
4.5. Measuring Results	10
5. Voltage Distortion in Differential mode Measurement	17
5.1. Block Diagram of Test Setup	17
5.2. Measuring Standard	17
5.3. Voltage Distortion in Differential mode Limits	17
5.4. Test Procedure	18
5.5. Measuring Results	18
6. RADIATED EMISSION MEASUREMENT (UP TO 1GHz)	23
6.1. Block Diagram of Test Setup	23
6.2. Measuring Standard	23
6.3. Radiated Emission Limits (Group 1 Class B).....	23
6.4. Test Procedure	24
6.5. Measuring Results	24
7. PHOTOGRAPHS	31
7.1. Photos of Conducted Emission Measurement	31
7.2. Photo of Voltage Distortion in Differential mode Measurement	32
7.3. Photos of Radiation Emission Measurement	32

APPENDIX: Photos of EUT and Labels

TEST REPORT DESCRIPTION

Applicant : Shenzhen Lux Power technology Co., LTD
Manufacturer : Shenzhen Lux Power technology Co., LTD
Trademark : 
Product Name : Energy Storage Inverter
Model No. : SNA PRO-EU 3K, SNA PRO-EU 4K, SNA PRO-EU 5K, SNA PRO-EU 6K, SNA PRO-EU 6.5K
Remark : This Report Shows that the EUT is technically compliant with The EMC (Radiation and Conduction) of SANS 211 requirements.

Measurement Procedure Used:

SANS 211:2010/CISPR 11:2015+A1:2016
(Industrial, scientific and medical equipment – Radio-frequency disturbance characteristics – Limits and methods of measurement)
SANS 61000-2-2:2002/IEC 61000-2-2:2002+A1:2017+A2:2018

The device described above is tested by EMTEK (SHENZHEN) CO., LTD. to determine the maximum emission levels emanating from the device and the severe levels of the device can endure and its performance criterion. The measurement results are contained in this test report and EMTEK (SHENZHEN) CO., LTD. is assumed full of responsibility for the accuracy and completeness of these measurements. Also, this report shows that the EUT (Equipment Under Test) is compliant with the SANS 211/CISPR 11 requirements.

This report applies to above tested sample only and shall not be reproduced in part without written approval of EMTEK (SHENZHEN) CO., LTD.

Date of Test : November 01, 2025 to November 17, 2025

Prepared by : 
Hu Min/Editor

Reviewer : 
Guo Kaimin/Supervisor

Approved & Authorized Signer : 
Wang Li/Manager

Modified Information

Version	Report No.	Revision Date	Summary
Ver.1.0	ENS2511120219E00101R	/	Original Report



1. SUMMARY OF TEST RESULT

EMISSION			
Description of Test Item	Standard	Limits	Results
Conducted Disturbance at Mains Terminals	SANS 211:2010/CISPR 11:2015+A1:2016	Class A	Pass
Voltage Distortion in Differential mode	SANS 61000-2-2:2002/IEC 61000-2-2:2002+A1:2017+A2:2018	Table 4	Pass
Radiated Disturbance	SANS 211:2010/CISPR 11:2015+A1:2016	Class B	Pass
Note: /			



2. GENERAL INFORMATION

2.1. Description of Device (EUT)

Product Name : Energy Storage Inverter

Model Number : SNA PRO-EU 3K, SNA PRO-EU 4K, SNA PRO-EU 5K, SNA PRO-EU 6K, SNA PRO-EU 6.5K
(Note: These models are identical in circuitry and electrical, mechanical and physical construction; the only differences are the rating. for trading purpose. We prepare SNA PRO-EU 6.5K for test.)

Applicant : Shenzhen Lux Power technology Co., LTD

Address : C501, Building A, Donghua Industrial Park, 5003 Bao'an Avenue, Sanwei Community, Hangcheng Street, Bao'an District, Shenzhen, 518126, China

Manufacturer : Shenzhen Lux Power technology Co., LTD

Address : C501, Building A, Donghua Industrial Park, 5003 Bao'an Avenue, Sanwei Community, Hangcheng Street, Bao'an District, Shenzhen, 518126, China

Factory : Shenzhen Lux Power technology Co., LTD

Address : C501, Building A, Donghua Industrial Park, 5003 Bao'an Avenue, Sanwei Community, Hangcheng Street, Bao'an District, Shenzhen, 518126, China

2.2. Independent Operation Modes

- A. ON
1. PV in & AC ON Grid
 2. AC Charging & AC Load
 3. Discharging & AC Back UP Load

2.3. Test Manner

Details of EUT Test Modes:

Test Items	Test Voltage	Function Type	Worst case
Conducted disturbance at mains Terminals	AC 230V/50Hz & DC 400V & DC 48V	Mode A.1 Mode A.2	Mode A.1
Voltage Distortion in Differential mode	AC 230V/50Hz & DC 400V & DC 48V	Mode A.1 Mode A.2	Mode A.1
Radiated emissions at frequencies up to 1 GHz	AC 230V/50Hz & DC 400V & DC 48V	Mode A	Mode A.3

2.4. Description of Test Facility

Site Description

EMC Lab.

: **Accredited by CNAS**

The Certificate Registration Number is L2291.

The Laboratory has been assessed and proved to be in compliance with CNAS-CL01 (identical to ISO/IEC 17025:2017)

Accredited by FCC

Designation Number: CN1204

Test Firm Registration Number: 882943

Accredited by A2LA

The Certificate Number is 4321.01.

Accredited by Industry Canada

The Conformity Assessment Body Identifier is CN0008

Name of Firm

: EMTEK (SHENZHEN) CO., LTD.

Site Location

: Building 69, Majialong Industry Zone, Nanshan District, Shenzhen, Guangdong, China

2.5. Measurement Uncertainty

Test Item	Uncertainty
Conducted Emission Uncertainty (Conduction 2#)	: 3.16dB(9k~150kHz Conduction) 2.90dB(150k~30MHz Conduction)
Radiated Emission Uncertainty (3m 3# Chamber)	: 4.28dB (30M~1GHz Polarize: H) 4.86dB (30M~1GHz Polarize: V)
Uncertainty for test site temperature and humidity	: 0.6°C 4%

3. MEASURING DEVICE AND TEST EQUIPMENT

3.1. For Power Line Conducted Emission Measurement

Used	Equipment	Manufacturer	Model No.	Serial No.	Last Cal.	Cal. Interval
<input checked="" type="checkbox"/>	EMI Test Receiver	Rohde & Schwarz	ESCI	101045	May 09, 2025	1 Year
<input checked="" type="checkbox"/>	PULSE LIMITER	Schwarzbeck	VTSD 9561 F-B	00955	May 09, 2025	1 Year
<input checked="" type="checkbox"/>	AMN	Schwarzbeck	NNLK 8129	8129203	May 09, 2025	1 Year
<input checked="" type="checkbox"/>	DC LISN	Schwarzbeck	PVDC 8301	00075	May 09, 2025	1 Year

3.2. For Voltage Distortion in Differential mode Measurement

Used	Equipment	Manufacturer	Model No.	Serial No.	Last Cal.	Cal. Interval
<input checked="" type="checkbox"/>	EMI Test Receiver	Rohde & Schwarz	ESCI	101045	May 09, 2025	1 Year
<input checked="" type="checkbox"/>	PULSE LIMITER	Schwarzbeck	VTSD 9561 F-B	00955	May 09, 2025	1 Year
<input checked="" type="checkbox"/>	AMN	Schwarzbeck	NNLK 8129	8129203	May 09, 2025	1 Year

3.3. For Radiated Emission Measurement

Used	Equipment	Manufacturer	Model No.	Serial No.	Last Cal.	Cal. Interval
<input checked="" type="checkbox"/>	EMI Test Receiver	Rohde & Schwarz	ESU 26	100154	May 09, 2025	1 Year
<input checked="" type="checkbox"/>	Pre-Amplifier	Lunar EM	LNA30M3G-25	J10100000070	May 09, 2025	1 Year
<input checked="" type="checkbox"/>	Bilog Antenna	Schwarzbeck	VULB9163	661	May 18, 2025	2 Year

4. POWER LINE CONDUCTED EMISSION MEASUREMENT

4.1. Block Diagram of Test Setup

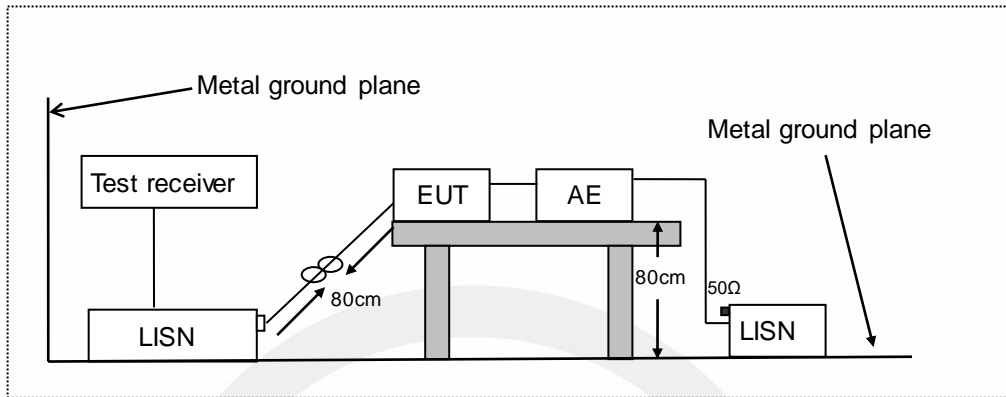

LISN: Artificial Mains Network
 AE: Associated equipment
 EUT: Equipment under test

4.2. Measuring Standard

SANS 211/CISPR 11

4.3. Power Line Conducted Emission Limits (Group 1 Class A)

Disturbance voltage limits for class A group 1 equipment measured on a test site (a.c. mains power port)

Frequency (MHz)	Limit (dB μ V)	
	Quasi-peak Level	Average Level
0.15 ~ 0.50	79.0	66.0
0.50 ~ 5.0	73.0	60.0
5.0 ~ 30.0	73.0	60.0

NOTE 1-The lower limit shall apply at the transition frequencies.

Limits for conducted disturbances of class A group 1 equipment measured on a test site (d.c. power port)

Frequency (MHz)	Limit (dB μ V)	
	Quasi-peak Level	Average Level
0.15 ~ 5.0	97	84
	to 89	76
5.0 ~ 30.0	89	76

NOTE 1-The lower limit shall apply at the transition frequencies.

4.4. Test Procedure

The EUT is put on the plane 0.8m high above the ground by insulating support and connected to the AC mains through Line Impedance Stability Network (L.I.S.N). This provided 50ohm-coupling impedance for the tested equipments. Both sides of AC line are investigated to find out the maximum conducted emission according to the SANS 211/CISPR 11 regulations during conducted emission measurement.

The bandwidth of the field strength meter (R&S Test Receiver ESCI) is set at 9kHz in 150kHz~30MHz and 200Hz in 9kHz~150kHz.

The frequency range from 150kHz to 30MHz is investigated.

Test results were obtained from the following equation:

Emission Level (dB μ V) = AMN Factor (dB) + Cable Loss (dB) + Reading (dB μ V)

Margin (dB) = Emission Level (dB μ V) - Limit (dB μ V)

4.5. Measuring Results

Pass.

All the modes were tested and the data of the worst modes are attached the following pages.

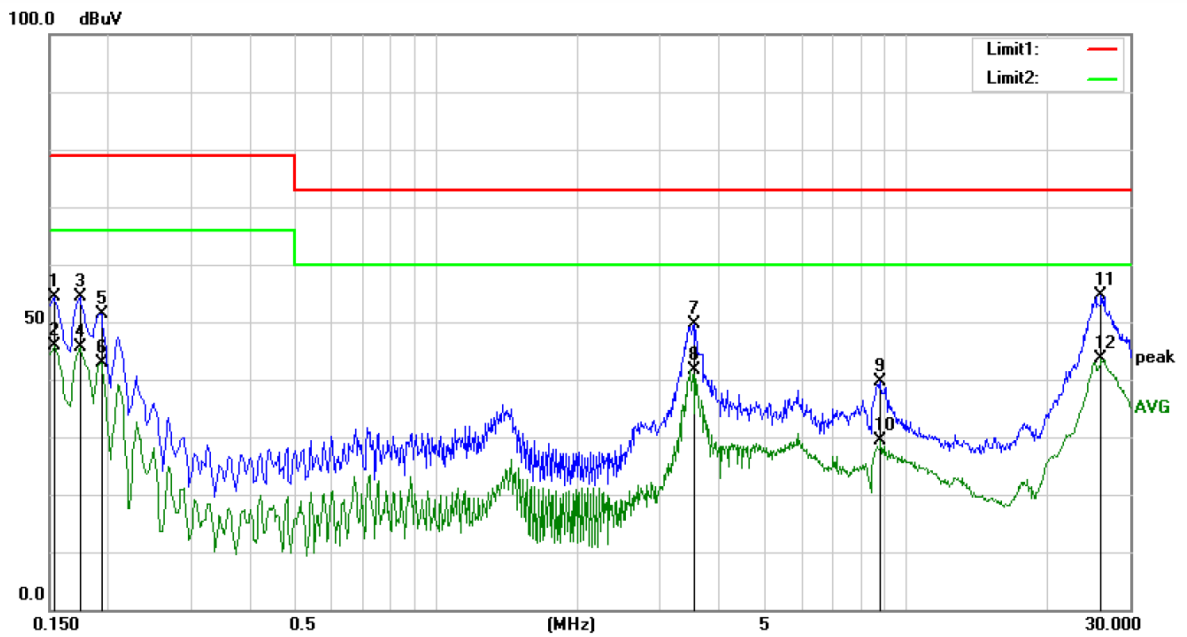

Site Conduction 2#

Phase: **L1**

Temperature: 26.1

Limit: (CE)CISPR 11 Class A_QP

Power: DC 400V&AC 230V/50Hz Humidity: 45 %

Mode: PV in&AC On Grid

Note:

No.	Mk.	Freq. MHz	Reading Level dBuV	Correct Factor dB	Measure- ment dBuV	Limit dBuV	Over dB	Detector	Comment
1		0.1540	43.86	10.62	54.48	79.00	-24.52	QP	
2		0.1540	35.35	10.62	45.97	66.00	-20.03	AVG	
3		0.1740	43.73	10.60	54.33	79.00	-24.67	QP	
4		0.1740	34.98	10.60	45.58	66.00	-20.42	AVG	
5		0.1940	40.89	10.59	51.48	79.00	-27.52	QP	
6		0.1940	32.41	10.59	43.00	66.00	-23.00	AVG	
7		3.5420	38.79	10.92	49.71	73.00	-23.29	QP	
8		3.5420	30.60	10.92	41.52	60.00	-18.48	AVG	
9		8.8180	28.36	11.21	39.57	73.00	-33.43	QP	
10		8.8180	18.09	11.21	29.30	60.00	-30.70	AVG	
11		26.0100	43.17	11.45	54.62	73.00	-18.38	QP	
12	*	26.0100	32.13	11.45	43.58	60.00	-16.42	AVG	

*:Maximum data x:Over limit !:over margin Comment: Factor build in receiver. Operator: Zhuowen Sheng

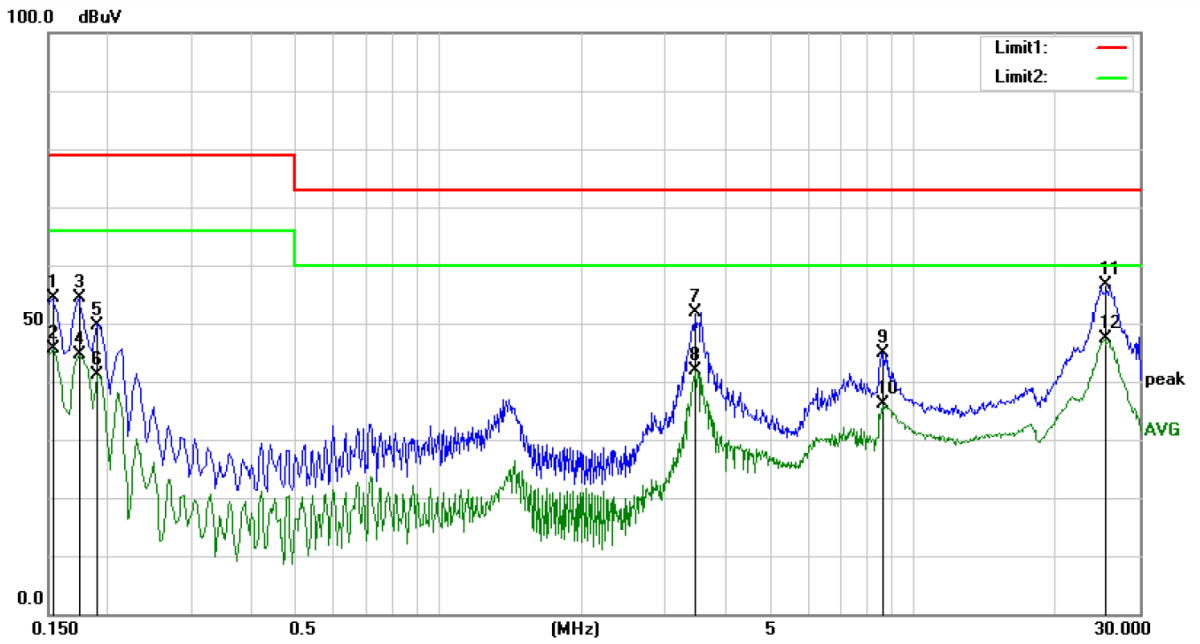

Site Conduction 2#

Phase: **N**

Temperature: 26.1

Limit: (CE)CISPR 11 Class A_QP

Power: DC 400V&AC 230V/50Hz

Humidity: 45 %

Mode: PV in&AC On Grid

Note:

No.	Mk.	Freq.	Reading Level	Correct Factor	Measurement	Limit	Over	Detector	Comment
		MHz	dBuV	dB	dBuV	dBuV	dB		
1		0.1540	43.78	10.61	54.39	79.00	-24.61	QP	
2		0.1540	35.03	10.61	45.64	66.00	-20.36	AVG	
3		0.1740	43.83	10.61	54.44	79.00	-24.56	QP	
4		0.1740	34.13	10.61	44.74	66.00	-21.26	AVG	
5		0.1900	39.05	10.62	49.67	79.00	-29.33	QP	
6		0.1900	30.42	10.62	41.04	66.00	-24.96	AVG	
7		3.4540	41.03	10.90	51.93	73.00	-21.07	QP	
8		3.4540	31.06	10.90	41.96	60.00	-18.04	AVG	
9		8.6140	33.68	11.18	44.86	73.00	-28.14	QP	
10		8.6140	24.88	11.18	36.06	60.00	-23.94	AVG	
11		25.3500	45.25	11.44	56.69	73.00	-16.31	QP	
12	*	25.3500	35.88	11.44	47.32	60.00	-12.68	AVG	

*:Maximum data x:Over limit !:over margin Comment: Factor build in receiver. Operator: Zhuowen Sheng

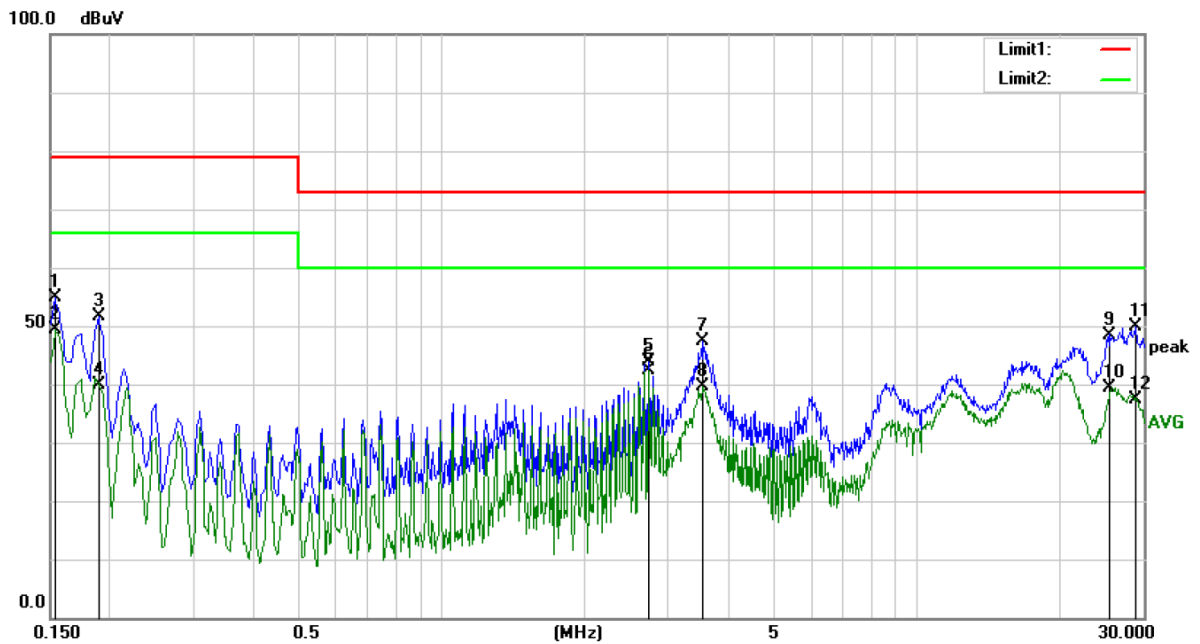

Site Conduction 2#

Phase: **L1**

Temperature: 26.1

Limit: (CE)CISPR 11 Class A_QP

Power: AC 230V/50Hz

Humidity: 45 %

Mode: AC Charging&AC Load

Note:

No.	Mk.	Freq.	Reading Level	Correct Factor	Measurement	Limit	Over	Detector	Comment
		MHz	dBuV	dB	dBuV	dBuV	dB		
1		0.1540	44.15	10.62	54.77	79.00	-24.23	QP	
2	*	0.1540	38.79	10.62	49.41	66.00	-16.59	AVG	
3		0.1900	40.94	10.60	51.54	79.00	-27.46	QP	
4		0.1900	29.29	10.60	39.89	66.00	-26.11	AVG	
5		2.7300	33.06	10.84	43.90	73.00	-29.10	QP	
6		2.7300	31.52	10.84	42.36	60.00	-17.64	AVG	
7		3.5340	36.51	10.91	47.42	73.00	-25.58	QP	
8		3.5340	28.73	10.91	39.64	60.00	-20.36	AVG	
9		25.5540	37.06	11.44	48.50	73.00	-24.50	QP	
10		25.5540	28.05	11.44	39.49	60.00	-20.51	AVG	
11		28.9980	38.43	11.47	49.90	73.00	-23.10	QP	
12		28.9980	25.94	11.47	37.41	60.00	-22.59	AVG	

*:Maximum data x:Over limit !:over margin Comment: Factor build in receiver. Operator: Zhuowen Sheng

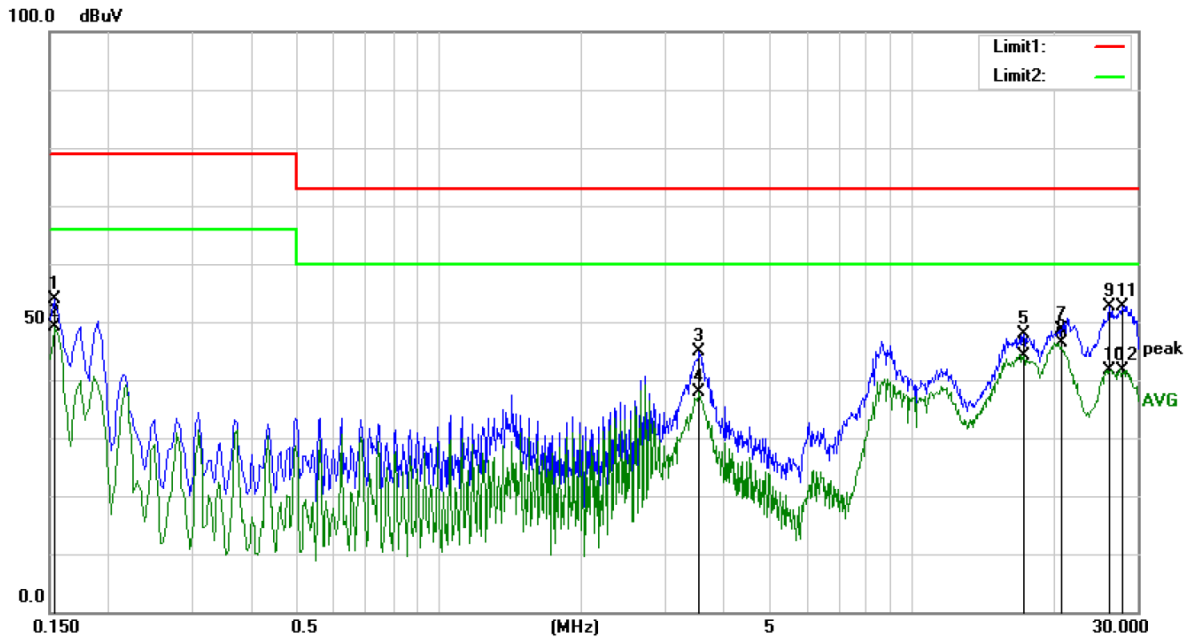

Site Conduction 2#

Phase: **N**

Temperature: 26.1

Limit: (CE)CISPR 11 Class A_QP

Power: AC 230V/50Hz

Humidity: 45 %

Mode: AC Charging&AC Load

Note:

No.	Mk.	Freq. MHz	Reading Level dBuV	Correct Factor dB	Measure- ment dBuV	Limit dBuV	Over dB	Detector	Comment
1		0.1540	43.33	10.61	53.94	79.00	-25.06	QP	
2		0.1540	38.42	10.61	49.03	66.00	-16.97	AVG	
3		3.5540	33.87	10.89	44.76	73.00	-28.24	QP	
4		3.5540	26.97	10.89	37.86	60.00	-22.14	AVG	
5		17.2420	36.38	11.39	47.77	73.00	-25.23	QP	
6		17.2420	32.86	11.39	44.25	60.00	-15.75	AVG	
7		20.6540	37.12	11.40	48.52	73.00	-24.48	QP	
8	*	20.6540	35.04	11.40	46.44	60.00	-13.56	AVG	
9		26.2340	41.21	11.45	52.66	73.00	-20.34	QP	
10		26.2340	30.23	11.45	41.68	60.00	-18.32	AVG	
11		27.8780	41.24	11.46	52.70	73.00	-20.30	QP	
12		27.8780	30.26	11.46	41.72	60.00	-18.28	AVG	

*:Maximum data x:Over limit !:over margin Comment: Factor build in receiver. Operator: Zhuowen Sheng

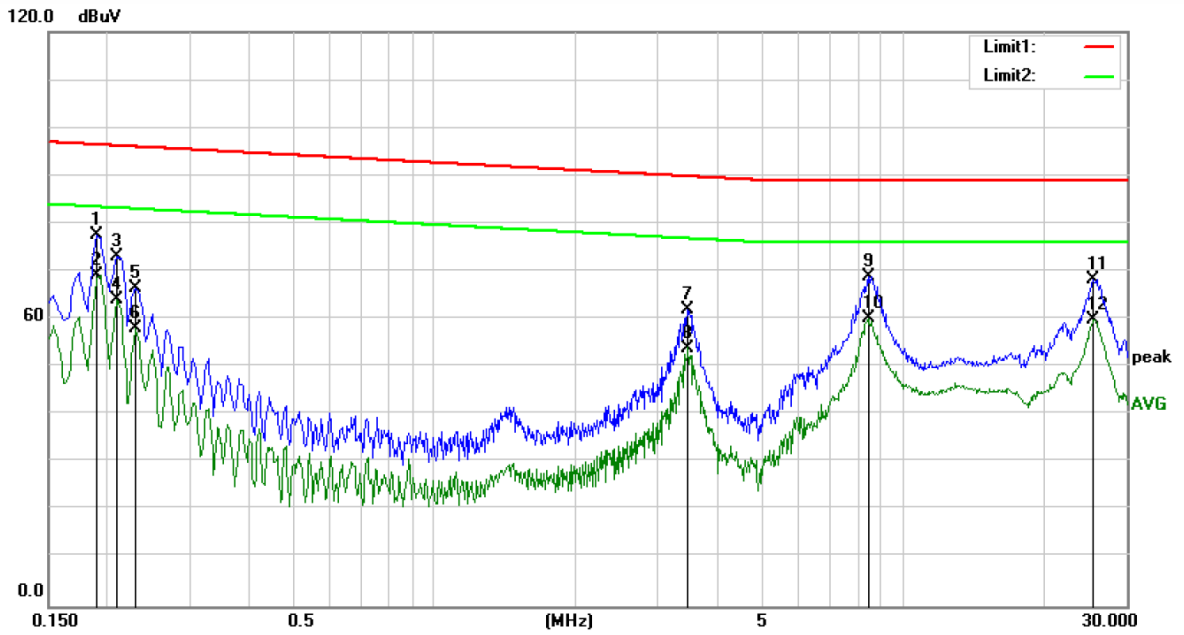

Site Conduction 2#

Phase: +

Temperature: 26.1

Limit: (CE)CISPR 11 Class A_QP

Power: DC 400V

Humidity: 45 %

Mode: PV in&AC On Grid

Note:

No.	Mk.	Freq. MHz	Reading Level dBuV	Correct Factor dB	Measure- ment dBuV	Limit dBuV	Over dB	Detector	Comment
1		0.1900	58.48	19.13	77.61	96.46	-18.85	QP	
2	*	0.1900	49.99	19.13	69.12	83.46	-14.34	AVG	
3		0.2100	53.96	19.04	73.00	96.23	-23.23	QP	
4		0.2100	44.87	19.04	63.91	83.23	-19.32	AVG	
5		0.2300	47.51	18.99	66.50	96.02	-29.52	QP	
6		0.2300	39.15	18.99	58.14	83.02	-24.88	AVG	
7		3.4540	43.23	18.70	61.93	89.84	-27.91	QP	
8		3.4540	35.30	18.70	54.00	76.84	-22.84	AVG	
9		8.4340	49.72	19.13	68.85	89.00	-20.15	QP	
10		8.4340	40.88	19.13	60.01	76.00	-15.99	AVG	
11		25.5620	47.43	20.91	68.34	89.00	-20.66	QP	
12		25.5620	39.03	20.91	59.94	76.00	-16.06	AVG	

*:Maximum data x:Over limit !:over margin Comment: Factor build in receiver. Operator: Zhuowen Sheng

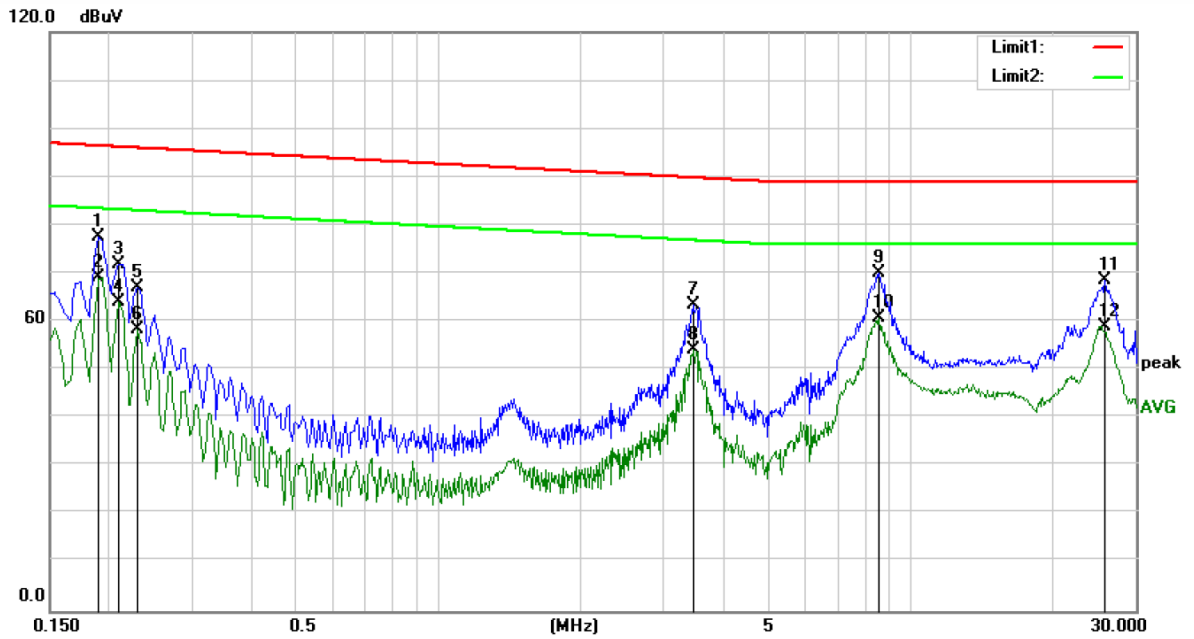

Site Conduction 2#

Phase: -

Temperature: 26.1

Limit: (CE)CISPR 11 Class A_QP

Power: DC 400V

Humidity: 45 %

Mode: PV in&AC On Grid

Note:

No.	Mk.	Freq. MHz	Reading Level dBuV	Correct Factor dB	Measure- ment dBuV	Limit dBuV	Over dB	Detector	Comment
1		0.1900	58.54	19.13	77.67	96.46	-18.79	QP	
2	*	0.1900	50.04	19.13	69.17	83.46	-14.29	AVG	
3		0.2100	52.74	19.04	71.78	96.23	-24.45	QP	
4		0.2100	44.96	19.04	64.00	83.23	-19.23	AVG	
5		0.2300	48.20	18.99	67.19	96.02	-28.83	QP	
6		0.2300	39.39	18.99	58.38	83.02	-24.64	AVG	
7		3.4540	44.66	18.70	63.36	89.84	-26.48	QP	
8		3.4540	35.58	18.70	54.28	76.84	-22.56	AVG	
9		8.5820	50.85	19.15	70.00	89.00	-19.00	QP	
10		8.5820	41.54	19.15	60.69	76.00	-15.31	AVG	
11		25.7740	47.72	20.91	68.63	89.00	-20.37	QP	
12		25.7740	38.15	20.91	59.06	76.00	-16.94	AVG	

*:Maximum data x:Over limit !:over margin Comment: Factor build in receiver. Operator: Zhuowen Sheng

5. VOLTAGE DISTORTION IN DIFFERENTIAL MODE MEASUREMENT

5.1. Block Diagram of Test Setup

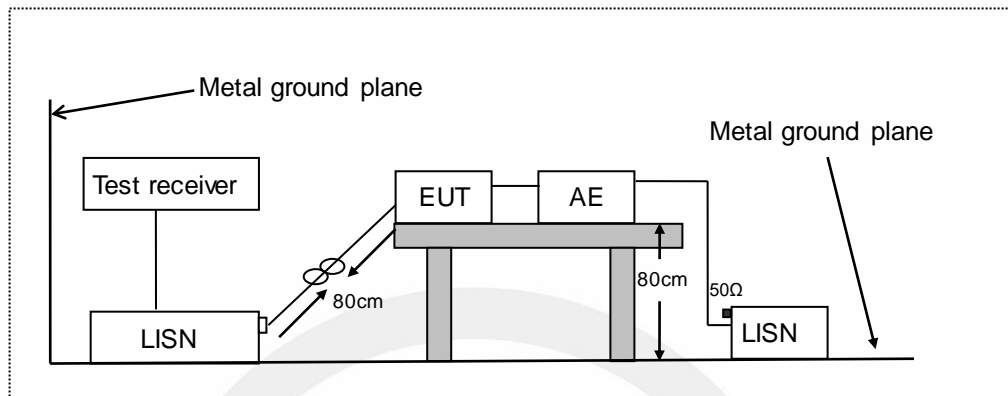

LISN: Artificial Mains Network
 AE: Associated equipment
 EUT: Equipment under test

5.2. Measuring Standard

SANS 61000-2-2:2002/IEC 61000-2-2:2002+A1:2017+A2:2018

5.3. Voltage Distortion in Differential mode Limits

Compatibility levels for voltage distortion in differential mode from 9 kHz to 150 kHz

1	2	3
Frequency range kHz	Compatibility levels dB(μV)	Emission levels dB(μV)
9 to 30	129.5 to 122	120.5 to 113
30 to 50	122 to 119	113 to 110
50 to 150	113 to 89	104 to 80
150 to 500		79
500 to 5000		73
5000 ^b to 30000		73

NOTE 1 The level decreases linearly with the logarithm of the frequency.
 NOTE 2 At the transition frequencies, the lower level applies.

5.4. Test Procedure

The EUT is put on the plane 0.8m high above the ground by insulating support and connected to the AC mains through Line Impedance Stability Network (L.I.S.N).

This provided 50ohm-coupling impedance for the tested equipments. Both sides of AC line are investigated to find out the maximum conducted emission according to the IEC 61000-2-2 regulations during conducted emission measurement.

The bandwidth of the field strength meter (R&S Test Receiver) is set at 200Hz in 9kHz~150kHz.

The frequency range from 9kHz to 150kHz is investigated.

Test results were obtained from the following equation:

Emission Level (dB μ V) = AMN Factor (dB) + Cable Loss (dB) + Reading (dB μ V)

Margin (dB) = Emission Level (dB μ V) - Limit (dB μ V)

5.5. Measuring Results

Pass.

All the modes were tested and the data of the worst modes are attached the following pages.

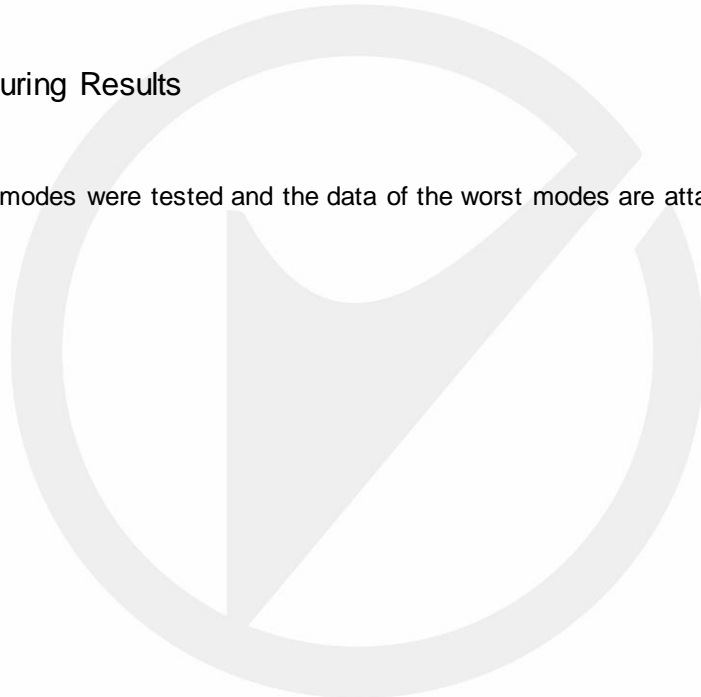

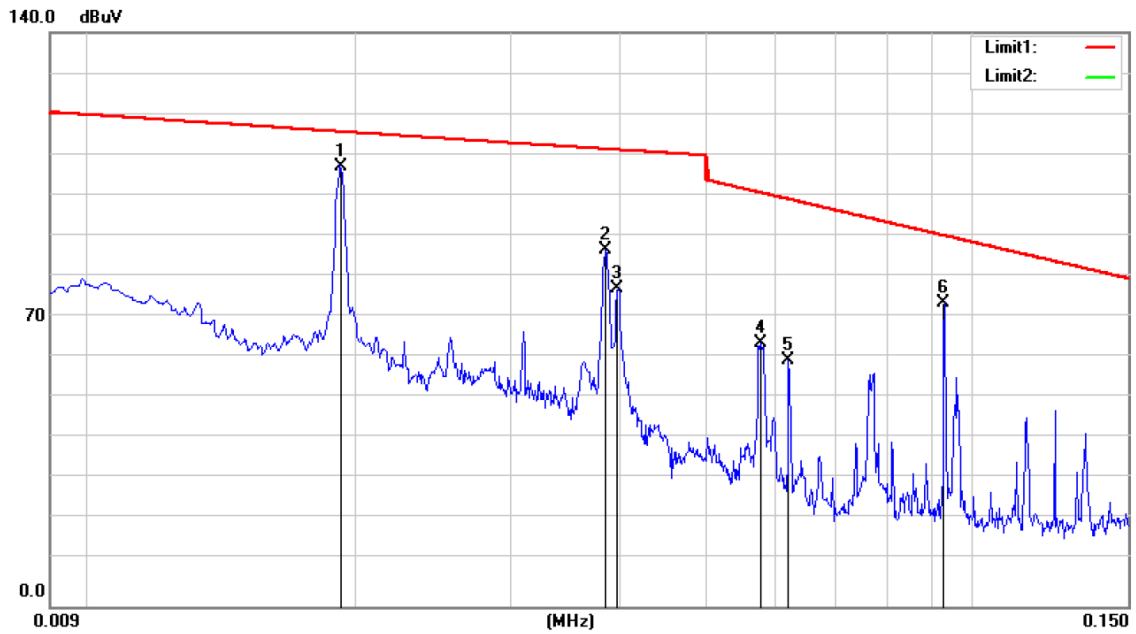

Site Conduction 2#

Phase: **L1**

Temperature: 26.1

Limit: (CE)IEC 61000-2-2_QP

Power: AC 230V/50Hz

Humidity: 45 %

Mode: AC Charging&AC Load

Note:

No.	Mk.	Freq. MHz	Reading Level dBuV	Correct Factor dB	Measure- ment dBuV	Limit dBuV	Over dB	Detector	Comment
1	*	0.0192	95.90	11.55	107.45	115.78	-8.33	QP	
2		0.0384	76.19	10.94	87.13	111.55	-24.42	QP	
3		0.0396	66.79	10.91	77.70	111.37	-33.67	QP	
4		0.0575	53.39	10.74	64.13	100.95	-36.82	QP	
5		0.0620	49.26	10.72	59.98	99.30	-39.32	QP	
6		0.0930	63.41	10.65	74.06	90.44	-16.38	QP	

*:Maximum data x:Over limit !:over margin Comment: Factor build in receiver. Operator: Zhuowen Sheng

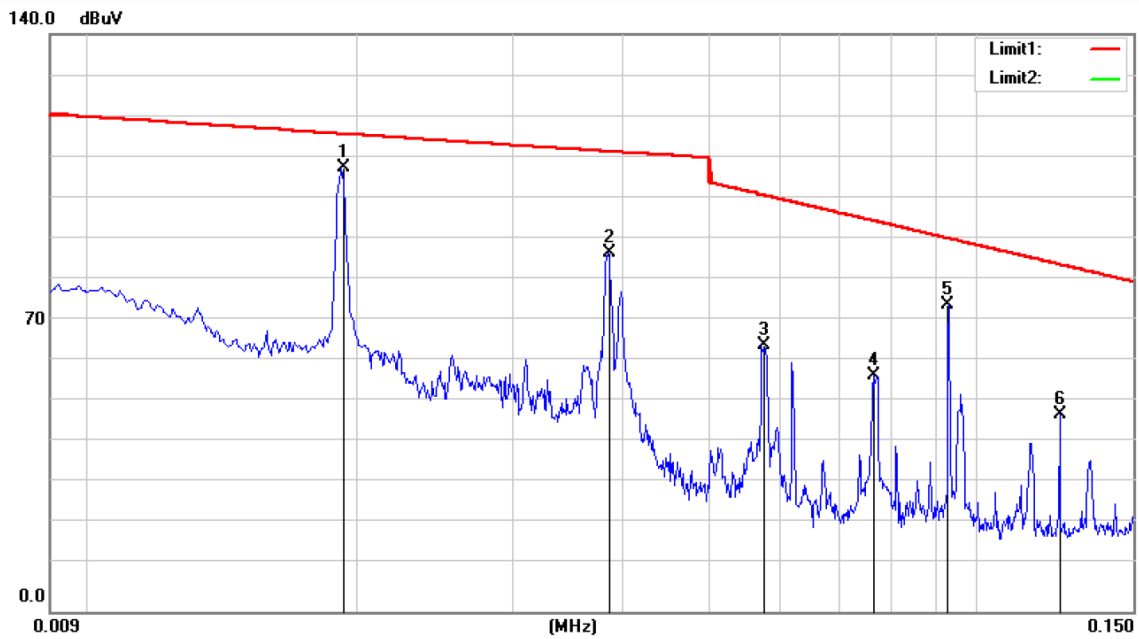

Site Conduction 2#

Phase: **N**

Temperature: 26.1

Limit: (CE)IEC 61000-2-2_QP
Mode: AC Charging&AC Load

Power: AC 230V/50Hz

Humidity: 45 %

Note:

No.	Mk.	Freq.	Reading Level	Correct Factor	Measurement	Limit	Over	Detector	Comment
		MHz	dBuV	dB	dBuV	dBuV	dB		
1	*	0.0191	96.12	11.57	107.69	115.81	-8.12	QP	
2		0.0384	76.13	10.96	87.09	111.55	-24.46	QP	
3		0.0573	53.85	10.76	64.61	101.02	-36.41	QP	
4		0.0764	46.58	10.68	57.26	94.74	-37.48	QP	
5		0.0930	63.55	10.67	74.22	90.44	-16.22	QP	
6		0.1240	37.01	10.64	47.65	84.16	-36.51	QP	

*:Maximum data x:Over limit !:over margin Comment: Factor build in receiver. Operator: Zhuowen Sheng

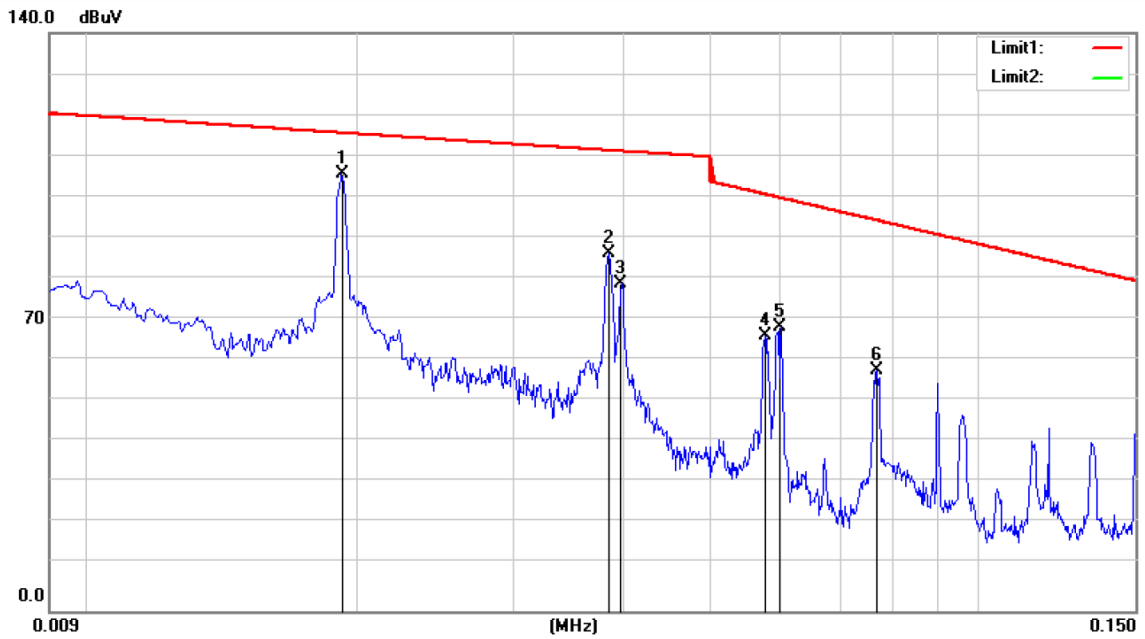

Site Conduction 2#

Phase: **L1**

Temperature: 26.1

Limit: (CE)IEC 61000-2-2_QP

Power: DC 400V&AC 230V/50Hz

Humidity: 45 %

Mode: PV in&AC On Grid

Note:

No.	Mk.	Freq. MHz	Reading Level dBuV	Correct Factor dB	Measure- ment dBuV	Limit dBuV	Over dB	Detector	Comment
1	*	0.0192	94.16	11.55	105.71	115.78	-10.07	QP	
2		0.0384	75.65	10.94	86.59	111.55	-24.96	QP	
3		0.0396	68.52	10.91	79.43	111.37	-31.94	QP	
4		0.0576	55.86	10.74	66.60	100.91	-34.31	QP	
5		0.0600	58.10	10.73	68.83	100.02	-31.19	QP	
6		0.0770	47.58	10.67	58.25	94.57	-36.32	QP	

*:Maximum data x:Over limit !:over margin Comment: Factor build in receiver. Operator: Zhuowen Sheng

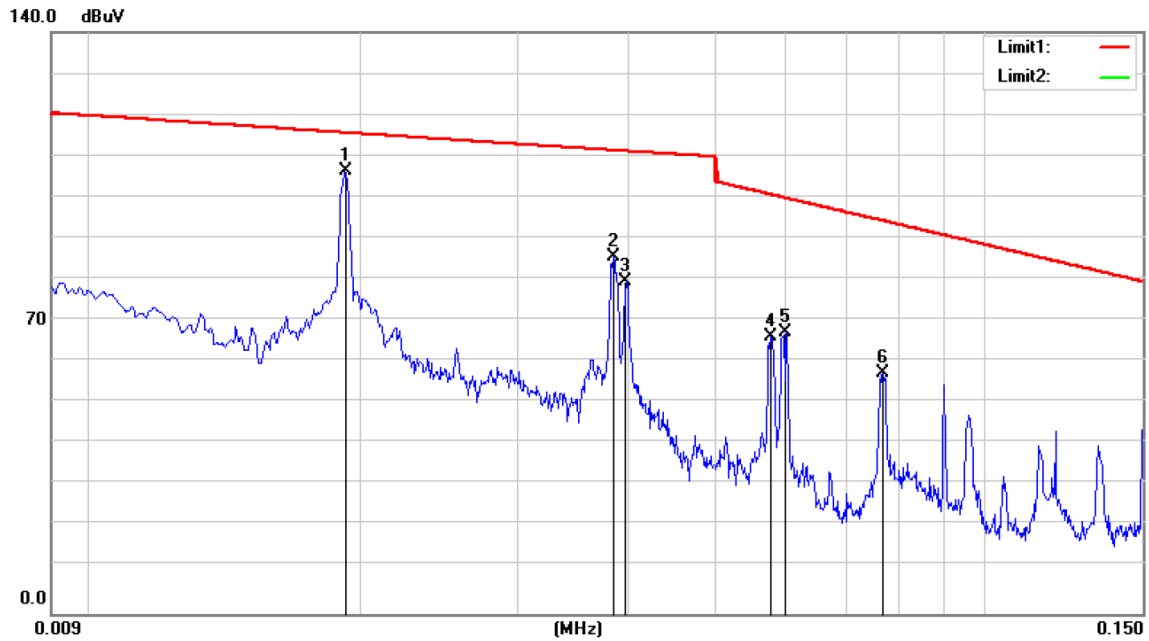

Site Conduction 2# Phase: **N** Temperature: 26.1
 Limit: (CE)IEC 61000-2-2_QP Power: DC 400V&AC 230V/50Hz Humidity: 45 %
 Mode: PV in&AC On Grid
 Note:

No.	Mk.	Freq.	Reading Level	Correct Factor	Measurement	Limit	Over	Detector	Comment
		MHz	dBuV	dB	dBuV	dBuV	dB		
1	*	0.0192	94.98	11.55	106.53	115.78	-9.25	QP	
2		0.0384	74.87	10.94	85.81	111.55	-25.74	QP	
3		0.0396	69.07	10.91	79.98	111.37	-31.39	QP	
4		0.0576	55.92	10.74	66.66	100.91	-34.25	QP	
5		0.0600	57.10	10.73	67.83	100.02	-32.19	QP	
6		0.0770	47.20	10.67	57.87	94.57	-36.70	QP	

*:Maximum data x:Over limit !:over margin Comment: Factor build in receiver. Operator: Zhuowen Sheng

6. RADIATED EMISSION MEASUREMENT (UP TO 1GHz)

6.1. Block Diagram of Test Setup

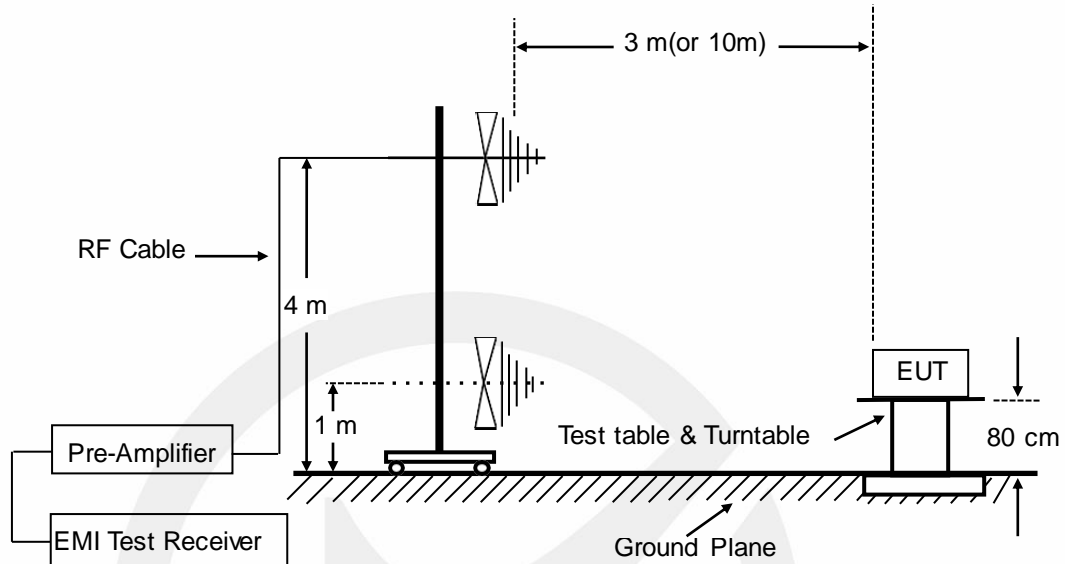

6.2. Measuring Standard

SANS 211/CISPR 11

6.3. Radiated Emission Limits (Group 1 Class B)

All emanations from a Group 1 Class B device or system, including any network of conductors and apparatus connected thereto, shall not exceed the level of field strengths specified below:

FREQUENCY (MHz)	DISTANCE (Meters)	FIELD STRENGTHS LIMIT (dB μ V/m)
30 ~ 230	3	40
230 ~ 1000	3	47

- Note: (1) The smaller limit shall apply at the combination point between two frequency bands.
 (2) Distance refers to the distance in meters between the measuring instrument antenna and the closed point of any part of the EUT.
 (3) Intended to be permanently installed in X-ray shielded locations, an increase in the electromagnetic radiation disturbance limits of 12 dB for tests conducted on a test site is allowed.

6.4. Test Procedure

The EUT is placed on a turntable, which is 0.8 meter high above the ground. The turntable can rotate 360 degrees to determine the position of the maximum emission level. The EUT is set 3 meters away from the receiving antenna, which is mounted on an antenna tower. The antenna can be moved up and down from 1 to 4 meters to find out the maximum emission level. Bilog antenna (calibrated by Dipole Antenna) is used as a receiving antenna. Both horizontal and vertical polarization of the antenna is set on test.

The bandwidth of the Receiver is set at 120kHz.

Test results were obtained from the following equation:

Emission level (dB μ V/m) = Antenna Factor -Amp Factor +Cable Loss + Reading

Margin (dB) = Emission Level (dB μ V/m) - Limit (dB μ V/m).

6.5. Measuring Results

Pass.

All the modes were tested and the data of the worst modes are attached the following pages

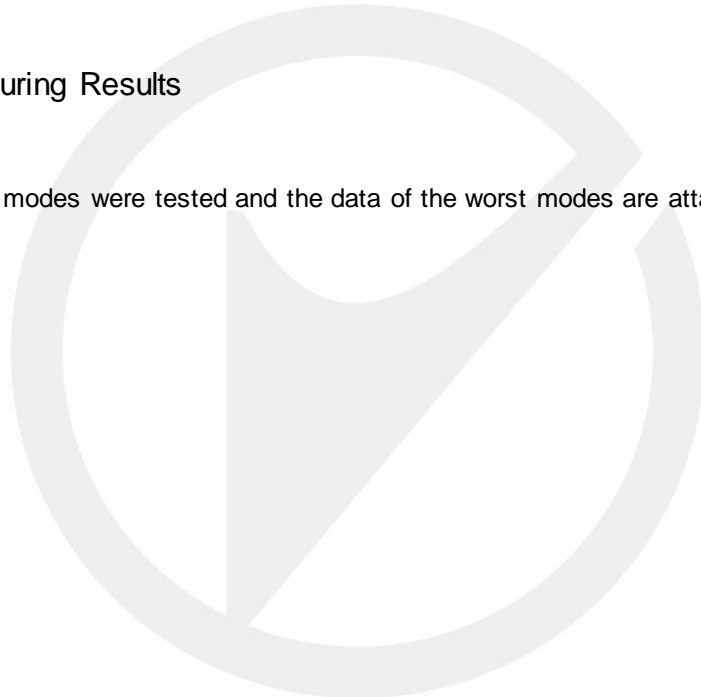

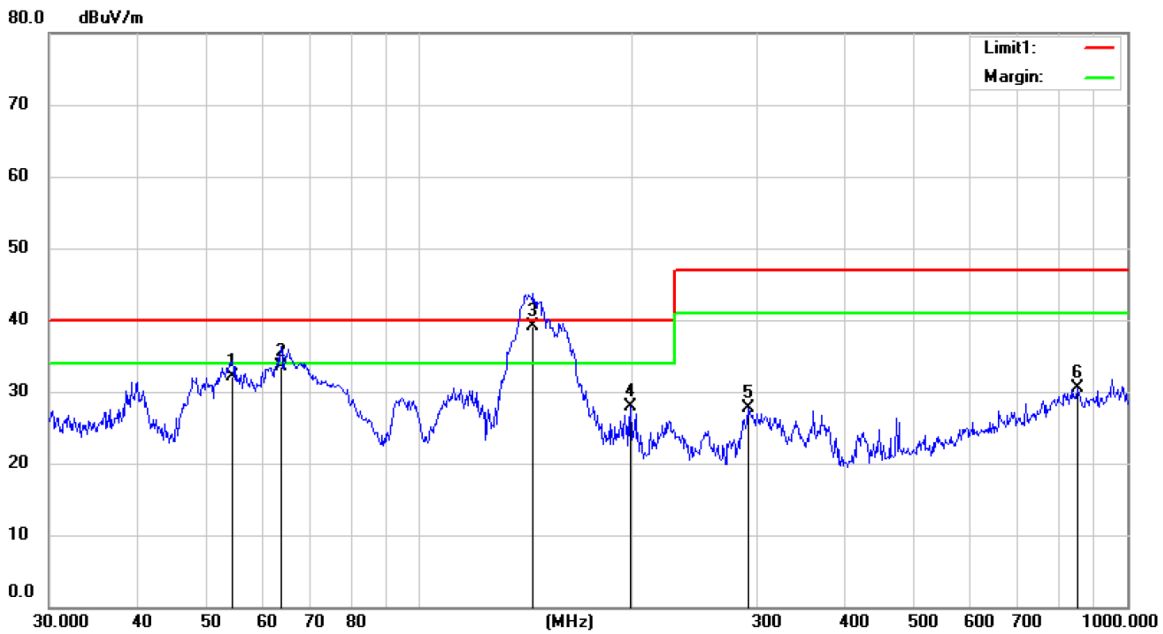

Site 3m Chamber #3 Polarization: **Horizontal** Temperature: 25.1 C
 Limit: CISPR 11 Class B Power: DC 400V&AC 230V/50Hz Humidity: 53 %
 Mode:PV IN&AC On Grid
 Note:

No.	Mk.	Freq.	Reading Level	Correct Factor	Measurement	Limit	Over	Antenna Height	Table Degree	Comment
		MHz	dBuV	dB	dBuV/m	dBuV/m	dB	cm	degree	
1		54.4754	45.41	-13.31	32.10	40.00	-7.90	QP		
2		63.9547	48.19	-14.69	33.50	40.00	-6.50	QP		
3	*	145.0960	56.31	-17.21	39.10	40.00	-0.90	QP		
4		199.0236	41.45	-13.64	27.81	40.00	-12.19	QP		
5		292.0583	38.14	-10.50	27.64	47.00	-19.36	QP		
6		852.9024	28.64	1.79	30.43	47.00	-16.57	QP		

*:Maximum data x:Over limit !:over margin Operator: Jiezhe Yin
 Remark: Above curve is pre-scan with Peak detector, and the final result is QP detector.

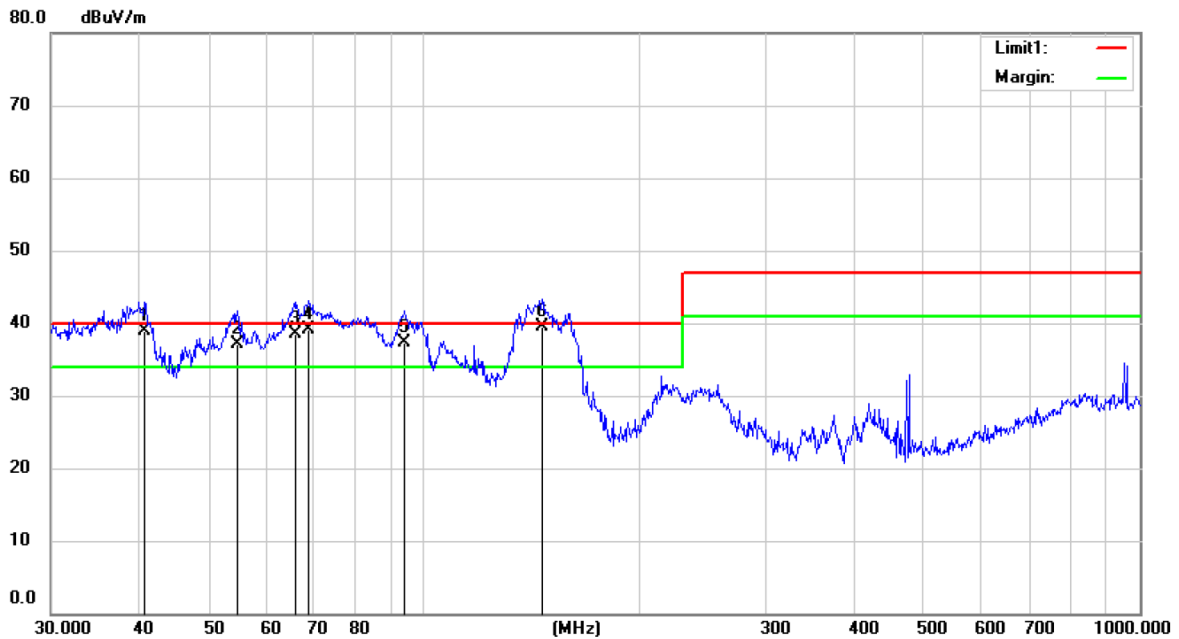

Site 3m Chamber #3 Polarization: **Vertical** Temperature: 25.1 C
 Limit: CISPR 11 Class B Power: DC 400V&AC 230V/50Hz Humidity: 53 %
 Mode:PV IN&AC On Grid
 Note:

No.	Mk.	Freq.	Reading Level	Correct Factor	Measurement	Limit	Over	Antenna Height	Table Degree	
		MHz	dBuV	dB	dBuV/m	dBuV/m	dB	Detector	cm	degree
1	!	40.5770	53.12	-14.22	38.90	40.00	-1.10	QP		
2	!	54.6668	50.58	-13.38	37.20	40.00	-2.80	QP		
3	!	66.1210	53.50	-15.00	38.50	40.00	-1.50	QP		
4	!	69.1140	54.78	-15.68	39.10	40.00	-0.90	QP		
5	!	93.8507	53.26	-15.96	37.30	40.00	-2.70	QP		
6	*	146.1811	56.74	-17.14	39.60	40.00	-0.40	QP		

*:Maximum data x:Over limit !:over margin

Operator: Jiezhe Yin

Remark: Above curve is pre-scan with Peak detector, and the final result is QP detector.

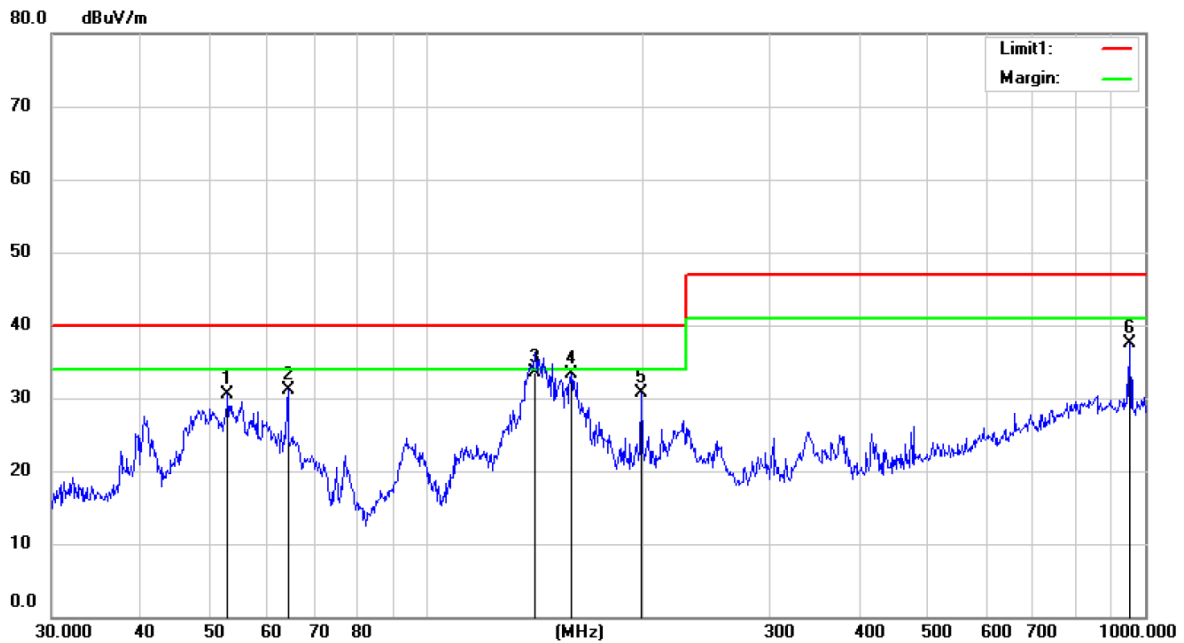

Site 3m Chamber #3 Polarization: **Horizontal** Temperature: 25.1 C
 Limit: CISPR 11 Class B Power: AC 230V/50Hz Humidity: 53 %
 Mode: AC Charging&AC Load
 Note:

No.	Mk.	Freq.	Reading Level	Correct Factor	Measurement	Limit	Over	Antenna Height	Table Degree	
		MHz	dBuV	dB	dBuV/m	dBuV/m	dB	cm	degree	Comment
1		52.8757	44.08	-13.49	30.59	40.00	-9.41	QP		
2		63.9827	45.76	-14.72	31.04	40.00	-8.96	QP		
3	*	141.5777	50.55	-17.05	33.50	40.00	-6.50	QP		
4		158.7373	49.69	-16.45	33.24	40.00	-6.76	QP		
5		199.1982	44.31	-13.64	30.67	40.00	-9.33	QP		
6		954.1826	36.44	0.97	37.41	47.00	-9.59	QP		

*:Maximum data x:Over limit !:over margin Operator: Jiezhe Yin
 Remark: Above curve is pre-scan with Peak detector, and the final result is QP detector.

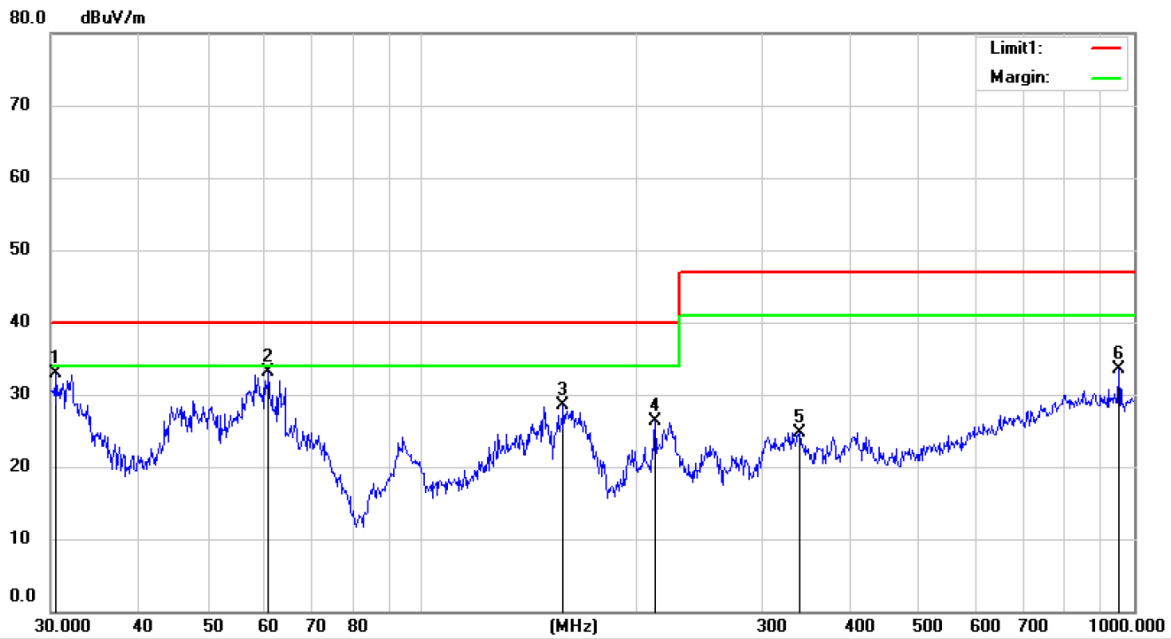

Site 3m Chamber #3 Polarization: **Horizontal** Temperature: 25.1 C
 Limit: CISPR 11 Class B Power: DC 48V Humidity: 53 %
 Mode: Discharging&AC Back up Load
 Note:

No.	Mk.	Freq.	Reading Level	Correct Factor	Measurement	Limit	Over	Antenna Height	Table Degree	Comment
		MHz	dBuV	dB	dBuV/m	dBuV/m	dB	cm	degree	
1		30.5842	48.64	-15.81	32.83	40.00	-7.17	QP		
2	*	60.7576	47.26	-14.08	33.18	40.00	-6.82	QP		
3		157.8354	45.12	-16.53	28.59	40.00	-11.41	QP		
4		212.2695	40.07	-13.71	26.36	40.00	-13.64	QP		
5		338.5484	34.09	-9.32	24.77	47.00	-22.23	QP		
6		953.7645	32.49	0.99	33.48	47.00	-13.52	QP		

*:Maximum data x:Over limit !:over margin

Operator: Jiezhe Yin

Remark: Above curve is pre-scan with Peak detector, and the final result is QP detector.

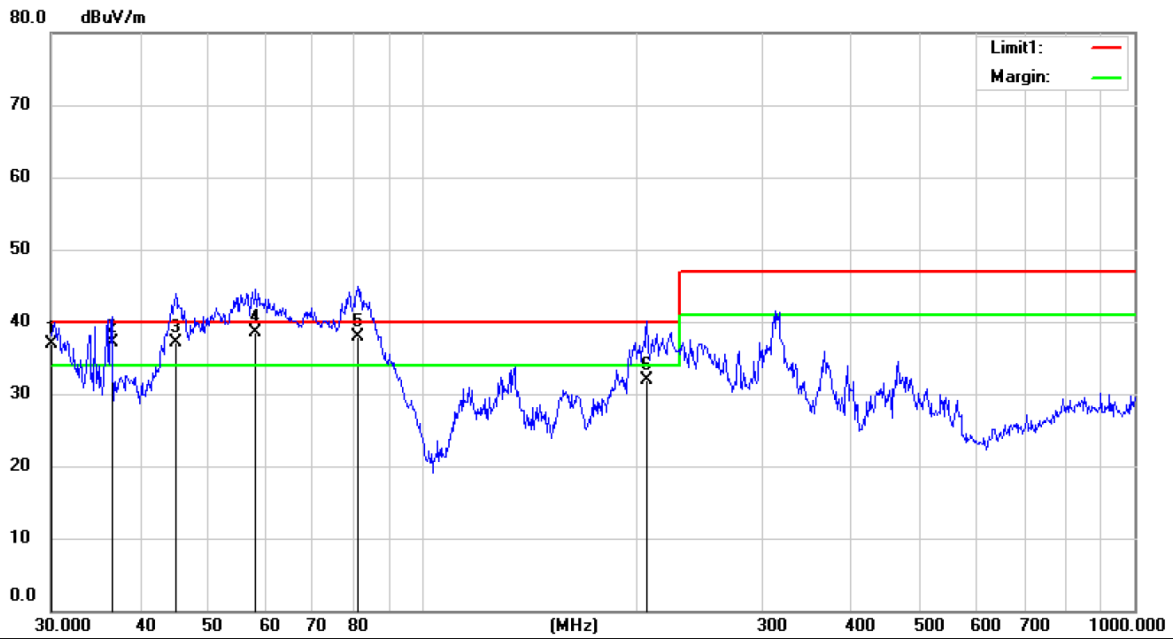

Site 3m Chamber #3 Polarization: **Vertical** Temperature: 26.0 C
 Limit: (RE)CISPR11 ClassB Power: DC 48V Humidity: 57 %
 Mode:Discharging&AC Back up Load
 Note:

No.	Mk.	Freq.	Reading Level	Correct Factor	Measurement	Limit	Over	Antenna Height	Table Degree	Detector	Comment
		MHz	dBuV	dB	dBuV/m	dBuV/m	dB	cm	degree		
1	*	30.5842	53.91	-15.81	38.10	40.00	-1.90			QP	
2	!	44.1202	50.87	-13.37	37.50	40.00	-2.50			QP	
3	!	58.2795	49.03	-13.83	35.20	40.00	-4.80			QP	
4		92.7464	49.83	-15.93	33.90	40.00	-6.10			QP	
5		131.2390	49.66	-17.21	32.45	40.00	-7.55			QP	
6		419.8435	40.42	-7.43	32.99	47.00	-14.01			QP	

*:Maximum data x:Over limit !:over margin Operator: Jiezhe Yin
 Remark: Above curve is pre-scan with Peak detector, and the final result is QP detector.

7. PHOTOGRAPHS

7.1. Photos of Conducted Emission Measurement



7.2. Photo of Voltage Distortion in Differential mode Measurement



7.3. Photos of Radiation Emission Measurement

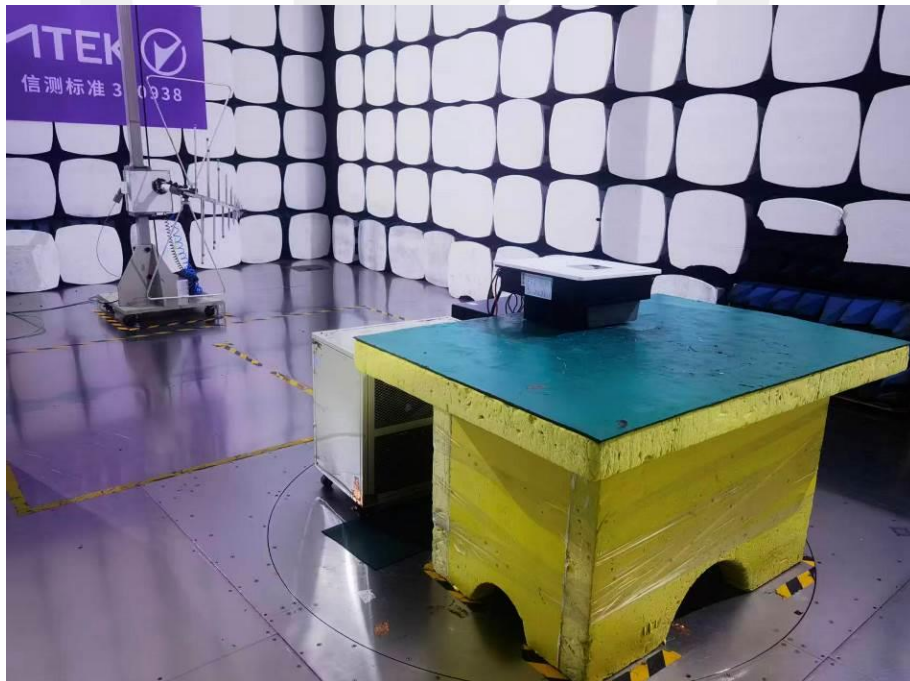

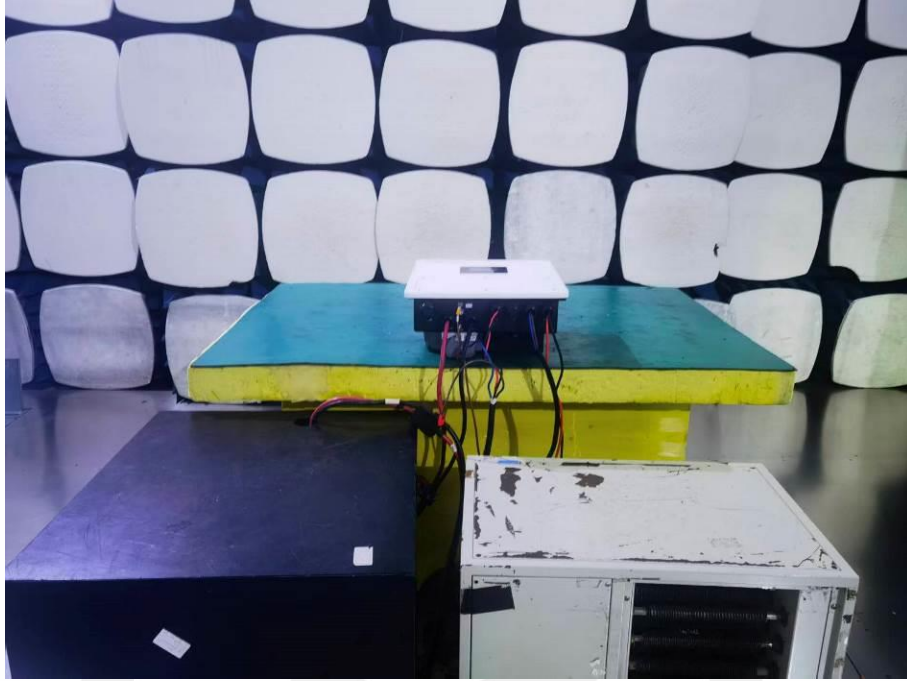

APPENDIX: Photos of EUT and Labels

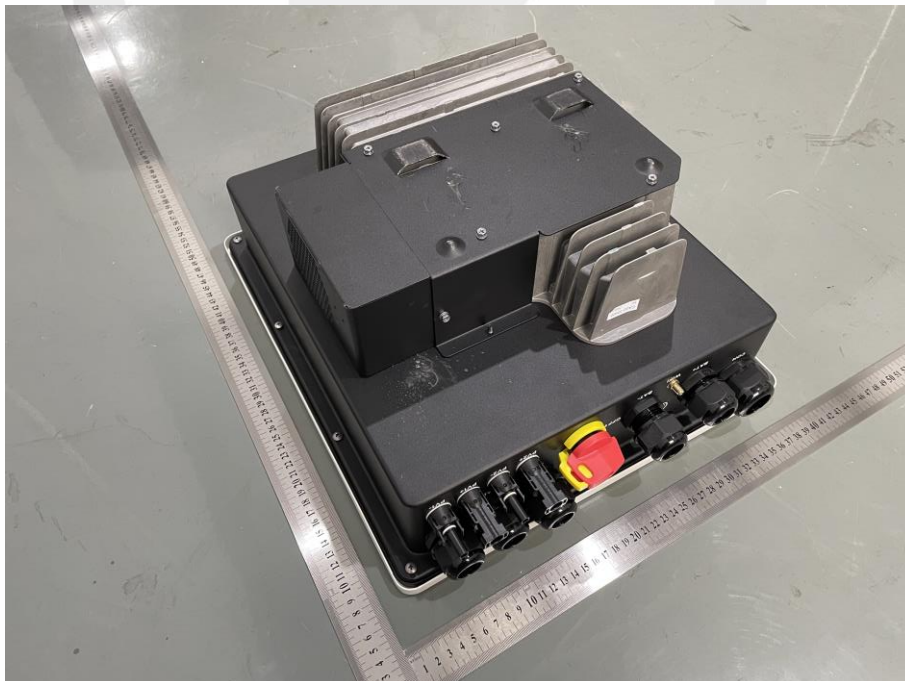
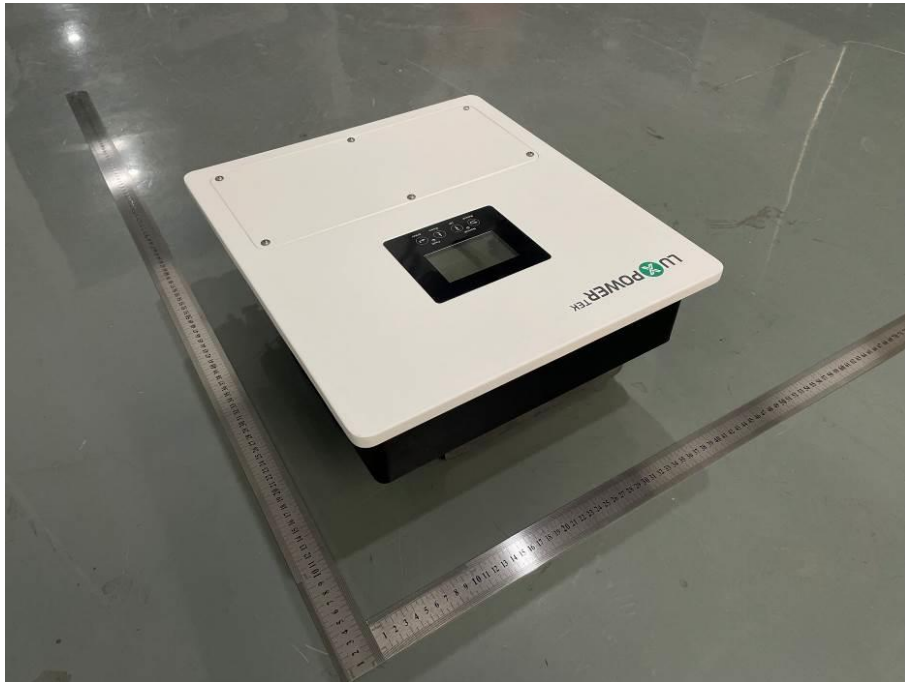

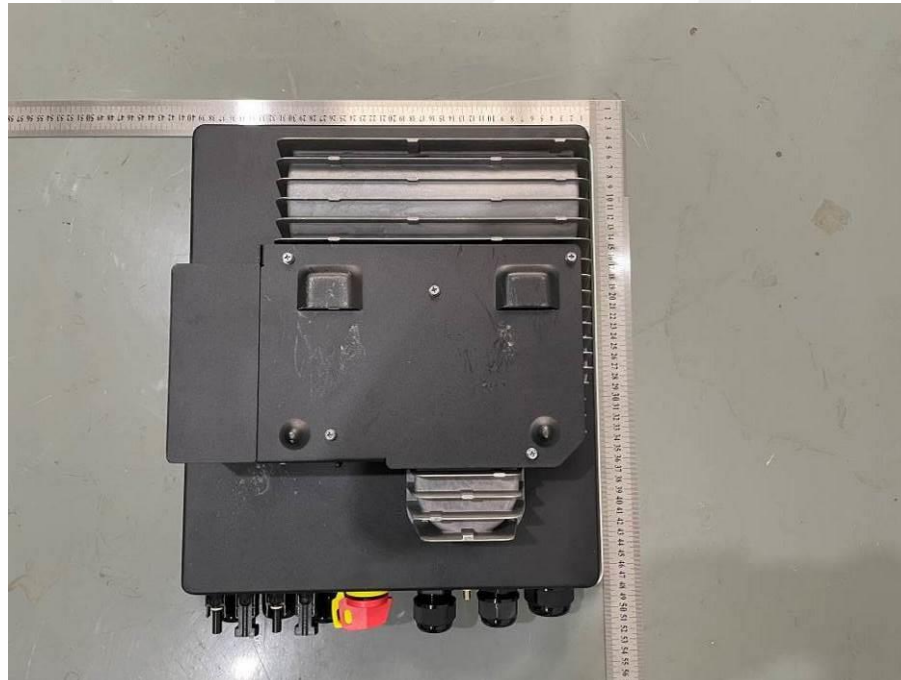

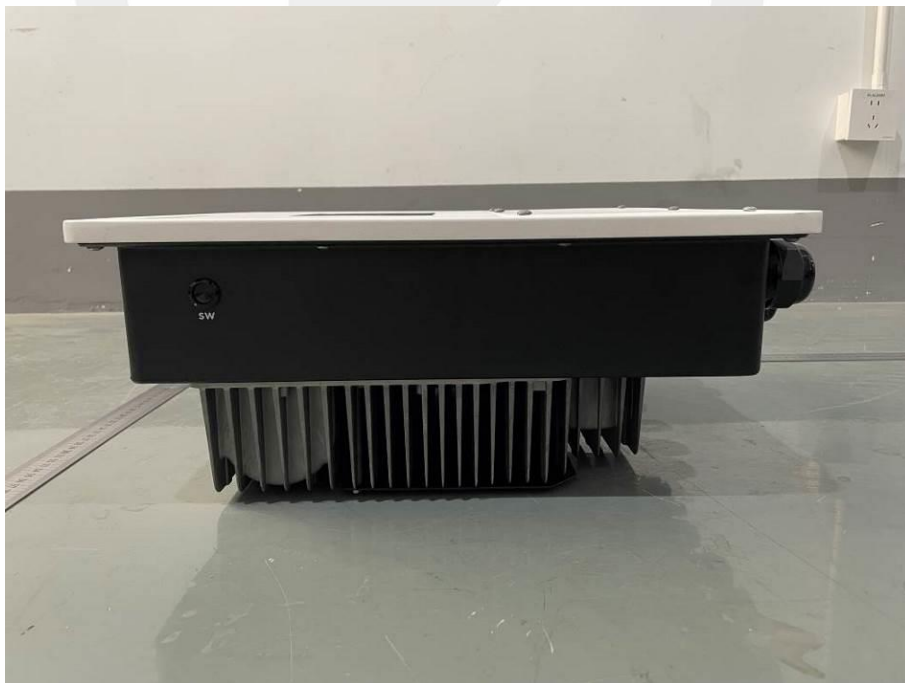

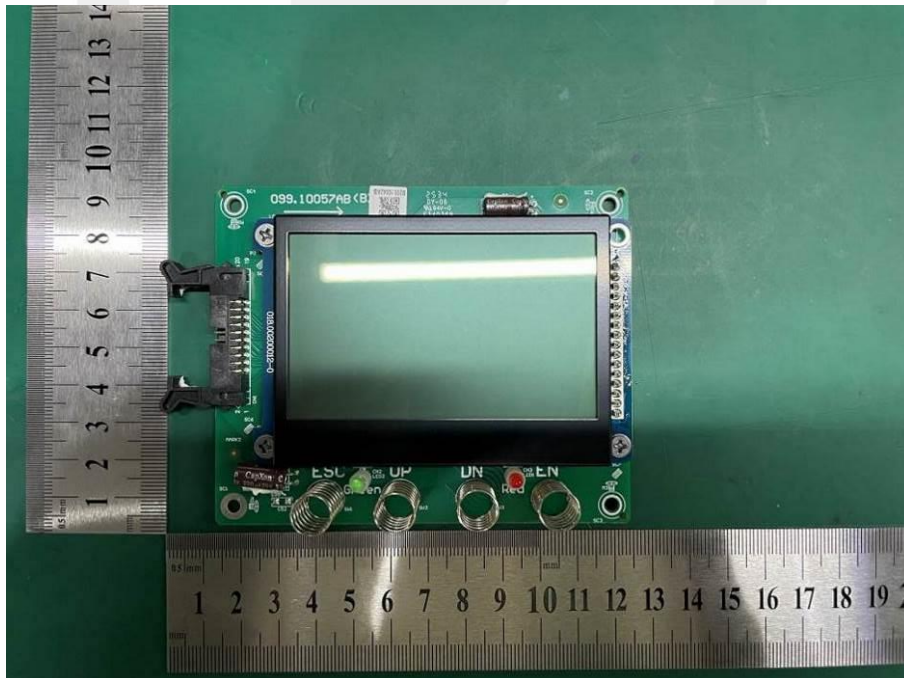
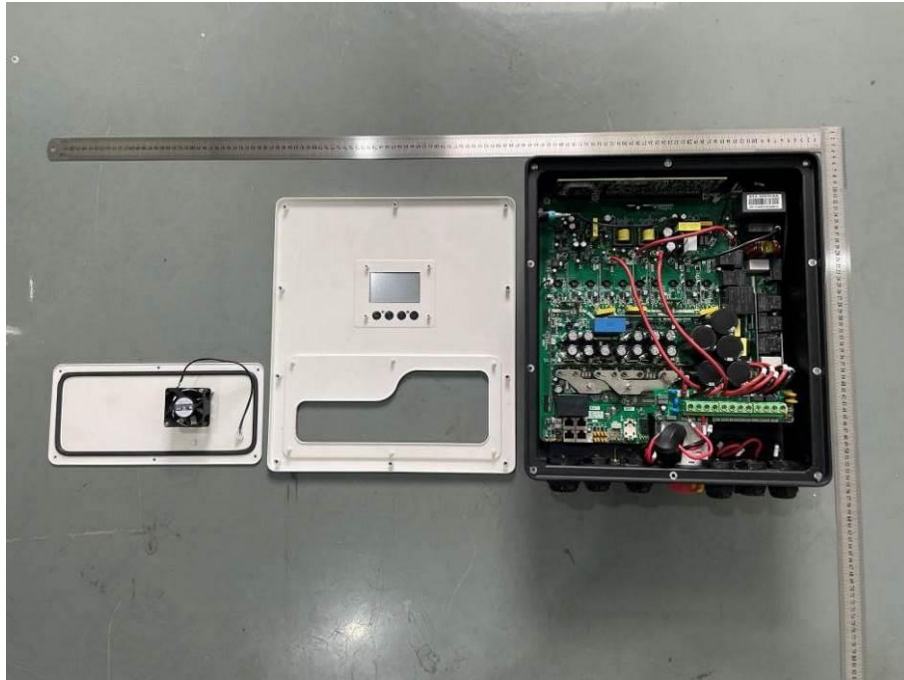

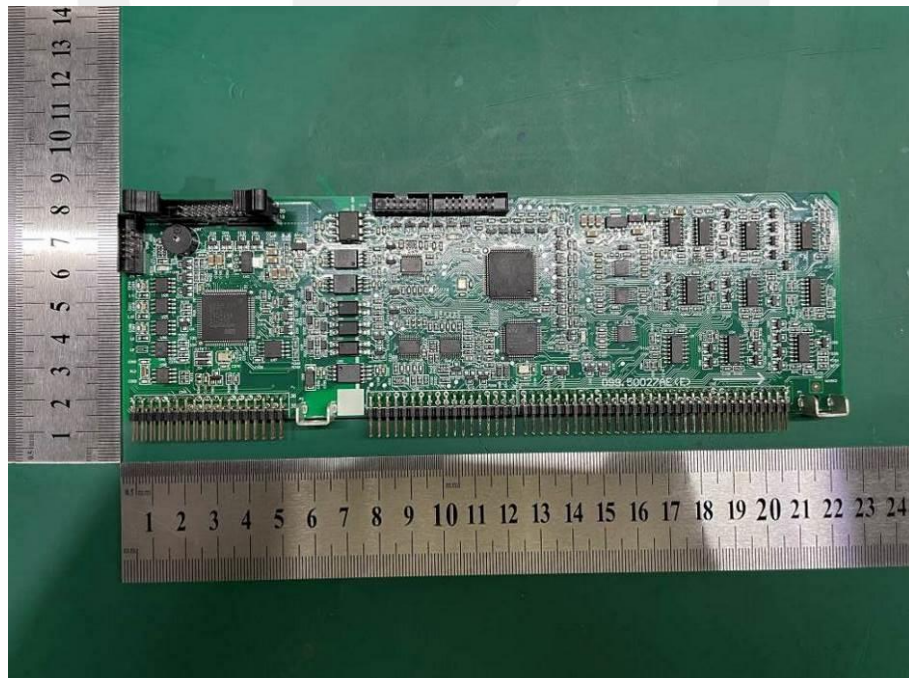
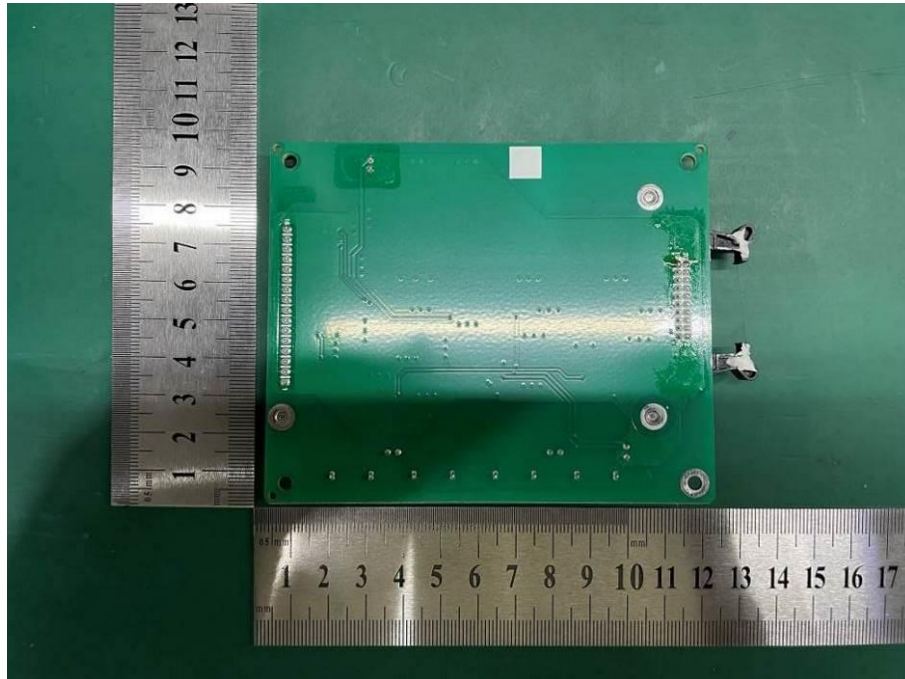

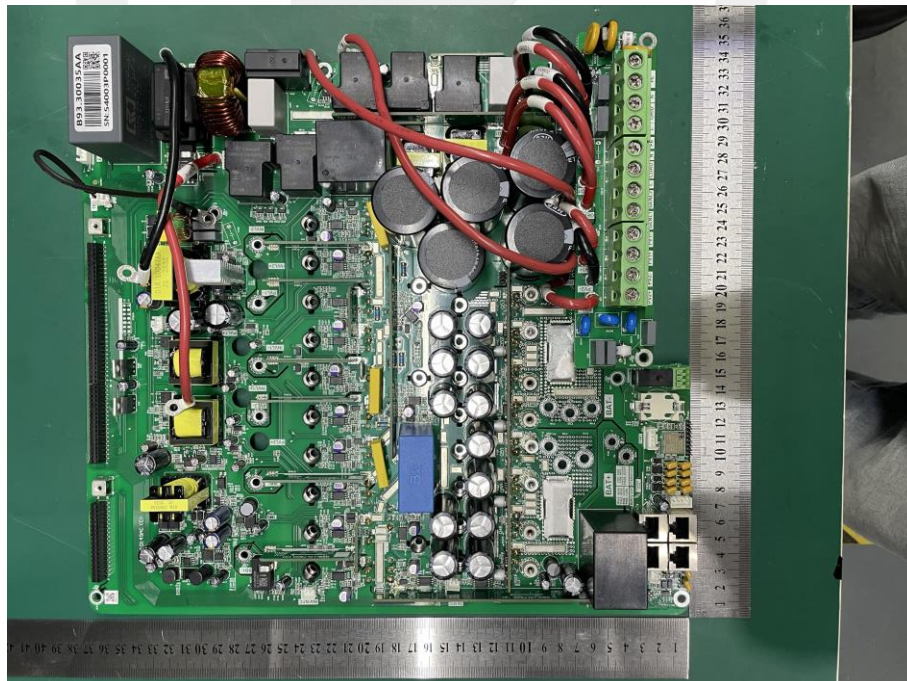
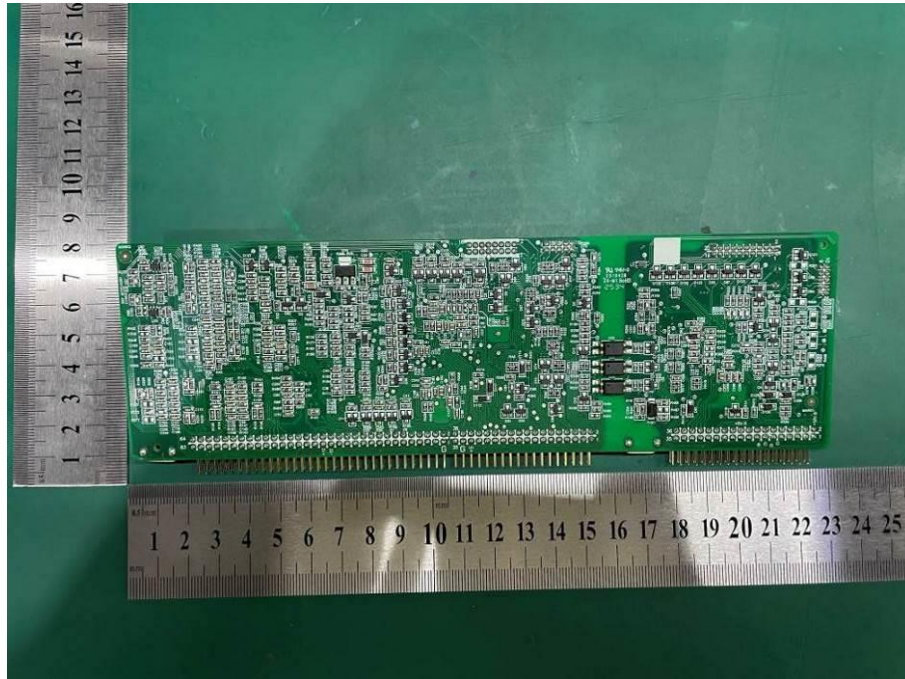

LU X POWER^{TEK}

Energy Storage Inverter

Model Name	SNA PRO-EU 3K
PV Input	
Max. PV Input voltage	500d.c.V
MPPT voltage range	80-400d.c.V
Number of MPPT Inputs	2
Inputs per MPPT	2/2
Max. PV short current(Input A/B)	25d.c.A/25d.c.A
Max. PV current(Input A/B)	20d.c.A/20d.c.A
Max. PV power	6000W(3000W+3000W)
AC Input	
Nominal AC voltage, Frequency	230.a.c.V,50Hz/60Hz
Max. GRID Input	26a.c.A,6000W
Max. GEN Input	13a.c.A,3000W
Max. AC charging power to battery	3000W
AC Output(Back-up)	
Nominal voltage,current	230a.c.V/13a.c.A
Frequency	50Hz/60Hz
Nominal output power	3000W(L-N)
Output power factor	0.6~1.0
Battery	
Battery type	Lithium-ion/Lead-Acid
Battery voltage range	38.4d.c.V-60d.c.V
Nominal voltage	48d.c.V
Max. charge and discharge current	70d.c.A/70d.c.A
Max. charge and discharge power	3000W
Environment	
Altitude	<6561ft
Ingress protection rating	IP65
Protective class	I
Operating environment temperature	0-45°C
Display	LCD+LED
Communication	RS485/WIFI/CAN



Shenzhen Lux Power Technology Co., Ltd
C501, Building A, Donghua Industrial Park, 5003 Bao'an Avenue, Sanwei Community, Hangcheng Street, Bao'an District, Shenzhen, 518126, China.

LU X POWER^{TEK}

Energy Storage Inverter

Model Name	SNA PRO-EU 4K
PV Input	
Max. PV Input voltage	500d.c.V
MPPT voltage range	80-400d.c.V
Number of MPPT Inputs	2
Inputs per MPPT	2/2
Max. PV short current(Input A/B)	25d.c.A/25d.c.A
Max. PV current(Input A/B)	20d.c.A/20d.c.A
Max. PV power	8000W(4000W+4000W)
AC Input	
Nominal AC voltage, Frequency	230.a.c.V,50Hz/60Hz
Max. GRID Input	35a.c.A,8000W
Max. GEN Input	32a.c.A,7370W
Max. AC charging power to battery	4000W
AC Output(Back-up)	
Nominal voltage,current	230a.c.V/17.5a.c.A
Frequency	50Hz/60Hz
Nominal output power	4000W(L-N)
Output power factor	0.6~1.0
Battery	
Battery type	Lithium-ion/Lead-Acid
Battery voltage range	38.4d.c.V-60d.c.V
Nominal voltage	48d.c.V
Max. charge and discharge current	90d.c.A/90d.c.A
Max. charge and discharge power	4000W
Environment	
Altitude	<6561ft
Ingress protection rating	IP65
Protective class	I
Operating environment temperature	0-45°C
Display	LCD+LED
Communication	RS485/WIFI/CAN



Shenzhen Lux Power Technology Co., Ltd
C501, Building A, Donghua Industrial Park, 5003 Bao'an Avenue, Sanwei Community, Hangcheng Street, Bao'an District, Shenzhen, 518126, China.

LU X POWER^{TEK}

Energy Storage Inverter

Model Name	SNA PRO-EU 5K
PV Input	
Max. PV Input voltage	500d.c.V
MPPT voltage range	80-400d.c.V
Number of MPPT Inputs	2
Inputs per MPPT	2/2
Max. PV short current(Input A/B)	25d.c.A/25d.c.A
Max. PV current(Input A/B)	20d.c.A/20d.c.A
Max. PV power	12000W(6000W+6000W)
AC Input	
Nominal AC voltage, Frequency	230.a.c.V,50Hz/60Hz
Max. GRID Input	35a.c.A,8000W
Max. GEN Input	32a.c.A,7370W
Max. AC charging power to battery	5000W
AC Output(Back-up)	
Nominal voltage,current	230a.c.V/22a.c.A
Frequency	50Hz/60Hz
Nominal output power	5000W(L-N)
Output power factor	0.6~1.0
Battery	
Battery type	Lithium-ion/Lead-Acid
Battery voltage range	38.4d.c.V-60d.c.V
Nominal voltage	48d.c.V
Max. charge and discharge current	110d.c.A/110d.c.A
Max. charge and discharge power	5000W
Environment	
Altitude	<6561ft
Ingress protection rating	IP65
Protective class	I
Operating environment temperature	0-45°C
Display	LCD+LED
Communication	RS485/WIFI/CAN



Shenzhen Lux Power Technology Co., Ltd
C501, Building A, Donghua Industrial Park, 5003 Bao'an Avenue, Sanwei Community, Hangcheng Street, Bao'an District, Shenzhen, 518126, China.

LU X POWER^{TEK}

Energy Storage Inverter

Model Name	SNA PRO-EU 6.5K
PV Input	
Max. PV Input voltage	500d.c.V
MPPT voltage range	80-400d.c.V
Number of MPPT Inputs	2
Inputs per MPPT	2/2
Max. PV short current(Input A/B)	25d.c.A/25d.c.A
Max. PV current(Input A/B)	20d.c.A/20d.c.A
Max. PV power	12000W(6000W+6000W)
AC Input	
Nominal AC voltage, Frequency	230.a.c.V,50Hz/60Hz
Max. GRID Input	39.1a.c.A,9000W
Max. GEN Input	32a.c.A,7370W
Max. AC charging power to battery	6500W
AC Output(Back-up)	
Nominal voltage,current	230a.c.V/28.2a.c.A
Frequency	50Hz/60Hz
Nominal output power	6500W(L-N)
Output power factor	0.6~1.0
Battery	
Battery type	Lithium-ion/Lead-Acid
Battery voltage range	38.4d.c.V-60d.c.V
Nominal voltage	48d.c.V
Max. charge and discharge current	135d.c.A/140d.c.A
Max. charge and discharge power	6500W/6500W
Environment	
Altitude	<6561ft
Ingress protection rating	IP65
Protective class	I
Operating environment temperature	0-45°C
Display	LCD+LED
Communication	RS485/WIFI/CAN



Shenzhen Lux Power Technology Co., Ltd
C501, Building A, Donghua Industrial Park, 5003 Bao'an Avenue, Sanwei Community, Hangcheng Street, Bao'an District, Shenzhen, 518126, China.

*** End of Report ***

Statement

- 1 . This report is invalid without the signature of the authorized approver and "special seal for testing".
- 2 . This report shall not be copied partly without authorization.
- 3 . The test results or observations are applicable only to tested sample. Client shall be responsible for representativeness of the sample and authenticity of the material.
- 4 . The observations or tests with special mark fall outside the scope of accreditation, and are only used for purpose of commission, research, training, internal quality control etc.
- 5 . The test results or observations are provided in accordance with measured value, without taking risks caused by uncertainty into account. Without explicit stipulation in special agreements, standards or regulations, EMTEK shall not assume any responsibility.
- 6 . Objections shall be raised within 20 days from the date receiving the report.