



TL-395

Test Report issued under the responsibility of



Total Quality. Assured.

<b>TEST REPORT</b> <b>IEC 62116</b> <b>Test procedure of islanding prevention measures for utility-interconnected photovoltaic inverters</b>	
<b>Report Number</b> .....	260302136GZU-002
<b>Date of issue</b> .....	12 Mar 2026
<b>Total number of pages</b> .....	16 Pages
<b>Name of Testing Laboratory preparing the Report</b> .....	Intertek Testing Services Shenzhen Ltd. Guangzhou Branch Room101/301/401/102/202/302/402/502/602/702/802, No. 7-2, Caipin Road, Huangpu District, Guangzhou, Guangdong, China.
<b>Applicant's name</b> .....	Shenzhen Lux Power Technology Co., Ltd.
<b>Address</b> .....	C501, Building A, Donghua Industrial Park, 5003 Bao'an Avenue, Sanwei Community, Hangcheng Street, Bao'an District, Shenzhen, 518126, China.
<b>Test specification:</b>	
<b>Standard</b> .....	IEC 62116:2014
<b>Test procedure</b> .....	Type approval
<b>Non-standard test method</b> .....	N/A
<b>Test Report Form No.</b> .....	IEC62116B
<b>Test Report Form(s) Originator</b> ....	TÜV SÜD Product Service GmbH
<b>Master TRF</b> .....	Dated 2017-11-03
<b>Copyright © 2017 IEC System of Conformity Assessment Schemes for Electrotechnical Equipment and Components (IECEE System). All rights reserved.</b> This publication may be reproduced in whole or in part for non-commercial purposes as long as the IECEE is acknowledged as copyright owner and source of the material. IECEE takes no responsibility for and will not assume liability for damages resulting from the reader's interpretation of the reproduced material due to its placement and context. If this Test Report Form is used by non-IECEE members, the IECEE/IEC logo and the reference to the CB Scheme procedure shall be removed. <b>This report is not valid as a CB Test Report unless signed by an approved CB Testing Laboratory and appended to a CB Test Certificate issued by an NCB in accordance with IECEE 02.</b>	
<b>General disclaimer:</b>	
The test results presented in this report relate only to the object tested. This report shall not be reproduced, except in full, without the written approval of the Issuing CB Testing Laboratory. The authenticity of this Test Report and its contents can be verified by contacting the NCB, responsible for this Test Report.	

<b>Test item description :</b>	Smart PCS																																																																																																					
<b>Trade Mark .....</b>	Lux Power																																																																																																					
<b>Manufacturer .....</b>	Same as Applicant																																																																																																					
<b>Model/Type reference :</b>	SNA PRO-EU 3K, SNA PRO-EU 4K, SNA PRO-EU 5K , SNA PRO-EU 6K, SNA PRO-EU 6.5K																																																																																																					
<b>Ratings .....</b>	<table border="1"> <thead> <tr> <th>Model</th> <th>SNA PRO-EU 3K</th> <th>SNA PRO-EU 4K</th> <th>SNA PRO-EU 5K</th> <th>SNA PRO-EU 6K</th> <th>SNA PRO-EU 6.5K</th> </tr> </thead> <tbody> <tr> <td colspan="6"><b>Input (PV)</b></td> </tr> <tr> <td>Max. input voltage</td> <td colspan="5">500 Vd.c.</td> </tr> <tr> <td>MPPT voltage range</td> <td colspan="5">80-400 Vd.c.</td> </tr> <tr> <td>Max. short-circuit current</td> <td colspan="5">25/25 Ad.c.</td> </tr> <tr> <td>Max. input current per MPPT</td> <td colspan="5">20/20 Ad.c.</td> </tr> <tr> <td colspan="6"><b>Input(Battery)</b></td> </tr> <tr> <td>Battery type</td> <td colspan="5">Lithium-ion/Lead-Acid</td> </tr> <tr> <td>Battery voltage range</td> <td colspan="5">38.4-60 Vd.c.</td> </tr> <tr> <td>Max. charging current</td> <td>70 Ad.c.</td> <td>90 Ad.c.</td> <td>110 Ad.c.</td> <td>135 Ad.c.</td> <td>135 Ad.c.</td> </tr> <tr> <td>Max. charging current power</td> <td>3000 W</td> <td>4000 W</td> <td>5000 W</td> <td>6000 W</td> <td>6500 W</td> </tr> <tr> <td colspan="6"><b>Output/Input (On Grid)</b></td> </tr> <tr> <td>Rated output power</td> <td>3000 W</td> <td>4000 W</td> <td>5000 W</td> <td>6000 W</td> <td>6500 W</td> </tr> <tr> <td>Rated input power</td> <td>6000 W</td> <td>8000 W</td> <td>8000 W</td> <td>9000 W</td> <td>9000 W</td> </tr> <tr> <td>Max. apparent power</td> <td>3000 VA</td> <td>4000 VA</td> <td>5000 VA</td> <td>6000 VA</td> <td>6500 VA</td> </tr> <tr> <td>Rated output voltage</td> <td colspan="5">220/230 Va.c., L/N/PE</td> </tr> </tbody> </table>						Model	SNA PRO-EU 3K	SNA PRO-EU 4K	SNA PRO-EU 5K	SNA PRO-EU 6K	SNA PRO-EU 6.5K	<b>Input (PV)</b>						Max. input voltage	500 Vd.c.					MPPT voltage range	80-400 Vd.c.					Max. short-circuit current	25/25 Ad.c.					Max. input current per MPPT	20/20 Ad.c.					<b>Input(Battery)</b>						Battery type	Lithium-ion/Lead-Acid					Battery voltage range	38.4-60 Vd.c.					Max. charging current	70 Ad.c.	90 Ad.c.	110 Ad.c.	135 Ad.c.	135 Ad.c.	Max. charging current power	3000 W	4000 W	5000 W	6000 W	6500 W	<b>Output/Input (On Grid)</b>						Rated output power	3000 W	4000 W	5000 W	6000 W	6500 W	Rated input power	6000 W	8000 W	8000 W	9000 W	9000 W	Max. apparent power	3000 VA	4000 VA	5000 VA	6000 VA	6500 VA	Rated output voltage	220/230 Va.c., L/N/PE				
Model	SNA PRO-EU 3K	SNA PRO-EU 4K	SNA PRO-EU 5K	SNA PRO-EU 6K	SNA PRO-EU 6.5K																																																																																																	
<b>Input (PV)</b>																																																																																																						
Max. input voltage	500 Vd.c.																																																																																																					
MPPT voltage range	80-400 Vd.c.																																																																																																					
Max. short-circuit current	25/25 Ad.c.																																																																																																					
Max. input current per MPPT	20/20 Ad.c.																																																																																																					
<b>Input(Battery)</b>																																																																																																						
Battery type	Lithium-ion/Lead-Acid																																																																																																					
Battery voltage range	38.4-60 Vd.c.																																																																																																					
Max. charging current	70 Ad.c.	90 Ad.c.	110 Ad.c.	135 Ad.c.	135 Ad.c.																																																																																																	
Max. charging current power	3000 W	4000 W	5000 W	6000 W	6500 W																																																																																																	
<b>Output/Input (On Grid)</b>																																																																																																						
Rated output power	3000 W	4000 W	5000 W	6000 W	6500 W																																																																																																	
Rated input power	6000 W	8000 W	8000 W	9000 W	9000 W																																																																																																	
Max. apparent power	3000 VA	4000 VA	5000 VA	6000 VA	6500 VA																																																																																																	
Rated output voltage	220/230 Va.c., L/N/PE																																																																																																					

Max. output current	13 Aa.c.	17.5 Aa.c.	22 Aa.c.	26.5 Aa.c.	28.2 Aa.c.
Max. input current	26 Aa.c.	35 Aa.c.	35 Aa.c.	39.1 Aa.c.	39.1 Aa.c.
Rated AC grid frequency	50/60 Hz				
Adjustable power factor	0.9 leading-0.9 lagging				
<b>Backup parameter (AC)</b>					
Rated output power	2000 W	2000 W	2000 W	3000 W	3000 W
Max. output current	8.6 Aa.c.	8.6 Aa.c.	8.6 Aa.c.	13 Aa.c.	13 Aa.c.
Rated output voltage	220/230 Va.c., L/N/PE				
AC frequency	50/60 Hz				
<b>General Data</b>					
Safety level	Class I				
Degree of protection	IP66				
Operating temperature range	-25~60 °C (derating at 45°C)				
FW Version	V1.0				

Responsible Testing Laboratory (as applicable), testing procedure and testing location(s):		
<input checked="" type="checkbox"/>	<b>Testing Laboratory:</b>	Intertek Testing Services Shenzhen Ltd. Guangzhou Branch
<b>Testing location/ address .....</b>		Room101/301/401/102/202/302/402/502/602/702/802, No. 7-2, Caipin Road, Huangpu District, Guangzhou, Guangdong, China.
<b>Tested by (name, function, signature) .....</b>		Charlie Yang Engineer <i>Charlie Yang</i>
<b>Approved by (name, function, signature) ..</b>		Jason Fu Supervisor <i>Jason Fu</i>
<hr/>		
<input type="checkbox"/>	<b>Testing procedure: CTF Stage 1:</b>	N/A
<b>Testing location/ address .....</b>		N/A
<b>Tested by (name, function, signature) .....</b>		N/A
<b>Approved by (name, function, signature) ..</b>		N/A
<hr/>		
<input type="checkbox"/>	<b>Testing procedure: CTF Stage 2:</b>	N/A
<b>Testing location/ address .....</b>		N/A
<b>Tested by (name + signature).....</b>		N/A
<b>Witnessed by (name, function, signature) .</b>		N/A
<b>Approved by (name, function, signature) ..</b>		N/A
<hr/>		
<input type="checkbox"/>	<b>Testing procedure: CTF Stage 3:</b>	N/A
<input type="checkbox"/>	<b>Testing procedure: CTF Stage 4:</b>	N/A
<b>Testing location/ address .....</b>		N/A
<b>Tested by (name, function, signature) .....</b>		N/A
<b>Witnessed by (name, function, signature) .</b>		N/A
<b>Approved by (name, function, signature) ..</b>		N/A
<b>Supervised by (name, function, signature) :</b>		N/A

<b>List of Attachments (including a total number of pages in each attachment):</b> Appendix 1: photos (2 pages)	
<b>Summary of testing:</b>	
<b>Tests performed (name of test and test clause):</b> All applicable tests	<b>Testing location:</b> Intertek Testing Services Shenzhen Ltd. Guangzhou Branch Room 101/301/401/102/202/302/402/502/602/702/ 802, No. 7-2, Caipin Road, Huangpu District, Guangzhou, Guangdong, China.
<b>Summary of compliance with National Differences (List of countries addressed):</b> N/A	
<input checked="" type="checkbox"/> <b>The product fulfils the requirements of IEC 62116:2014</b>	

**Copy of marking plate:**

The artwork below may be only a draft. The use of certification marks on a product must be authorized by the respective NCBs that own these marks.

<b>LU X POWER<sup>TEK</sup></b>	
<b>Energy Storage Inverter</b>	
<b>Model Name</b>	SNA PRO-EU 6.5K
<b>PV Input</b>	
Max. PV Input voltage	500d.c.V
MPPT voltage range	80-400d.c.V
Number of MPPT Inputs	2
Inputs per MPPT	1/1
Max. PV short current(Input A/B)	25d.c.A/25d.c.A
Max. PV current(Input A/B)	20d.c.A/20d.c.A
Max. PV power	12000W(6000W+6000W)
<b>AC Input</b>	
Nominal AC voltage, Frequency	230.a.c.V,50Hz/60Hz
Max. GRID Input	39.1a.c.A,9000W
Max. GEN Input	32a.c.A,7370W
Max. AC charging power to battery	6500W
<b>AC Output(Back-up)</b>	
Nominal voltage,current	230a.c.V/28.2a.c.A
Frequency	50Hz/60Hz
Nominal output power	6500W(L-N)
Output power factor	0.75~0.99
<b>Battery</b>	
Battery type	Lithium-ion/Lead-Acid
Battery voltage range	38.4d.c.V-60d.c.V
Nominal voltage	48d.c.V
Max. charge and discharge current	135d.c.A/140d.c.A
Max. charge and discharge power	6500W/6500W
<b>Environment</b>	
Altitude	<6561ft
Ingress protection rating	IP66
Protective class	I
Operating environment temperature	0-45°C
Display	LCD+LED
Communication	RS485/WIFI/CAN



Shenzhen Lux Power Technology Co., Ltd  
C501, Building A, Donghua Industrial Park, 5003 Bao'an Avenue, Sanwei Community, Hangcheng Street, Bao'an District, Shenzhen, 518126, China.

**Note:**

1. The above markings are the minimum requirements required by the safety standard. For the final production samples, the additional markings which do not give rise to misunderstanding may be added.
2. Label is attached on the side surface of enclosure and visible after installation.
3. Other models same as above except rating parameters.

<b>Test item particulars</b> .....:	
<b>Classification of installation and use</b> .....: Fixed and outdoor used	
<b>Supply Connection</b> .....: Permanent connection	
.....:	
<b>Possible test case verdicts:</b>	
- test case does not apply to the test object.....: N/A	
- test object does meet the requirement.....: P (Pass)	
- test object does not meet the requirement.....: F (Fail)	
<b>Testing</b> .....:	
<b>Date of receipt of test item</b> .....: 02 Mar 2026	
<b>Date (s) of performance of tests</b> .....: 03 Mar 2026 – 10 Mar 2026	
<b>General remarks:</b>	
<p>"(See Enclosure #)" refers to additional information appended to the report.          "(See appended table)" refers to a table appended to the report.  <b>Throughout this report a <input type="checkbox"/> comma / <input checked="" type="checkbox"/> point is used as the decimal separator.</b></p> <p>Determination of the test conclusion is based on IEC Guide 115 in consideration of measurement uncertainty.</p> <p>This report is for the exclusive use of Intertek's Client and is provided pursuant to the agreement between Intertek and its Client. Intertek's responsibility and liability are limited to the terms and conditions of the agreement. Intertek assumes no liability to any party, other than to the Client in accordance with the agreement, for any loss, expense or damage occasioned by the use of this report. Only the Client is authorized to permit copying or distribution of this report and then only in its entirety. Any use of the Intertek name or one of its marks for the sale or advertisement of the tested material, product or service must first be approved in writing by Intertek. The observations and test results in this report are relevant only to the sample tested. This report by itself does not imply that the material, product, or service is or has ever been under an Intertek certification program.</p> <p>The test report only allows to be revised only within the report defined retention period unless standard or regulation was withdrawn or invalid.</p>	
<b>Manufacturer's Declaration per sub-clause 4.2.5 of IEC 62116-2:</b>	
The application for obtaining a CB Test Certificate includes more than one factory location and a declaration from the Manufacturer stating that the sample(s) submitted for evaluation is (are) representative of the products from each factory has been provided .....:	<input type="checkbox"/> <b>Yes</b> <input checked="" type="checkbox"/> <b>Not applicable</b>
<b>When differences exist; they shall be identified in the General product information section.</b>	
<b>Name and address of factory (ies)</b> .....: Huizhou Jingchuangyuan Technology Co., Ltd No.86, Hechang 7th Road (W), Zhongkai High-tech Zone, Huizhou, Guangdong, China	

**General product information:**

- 1)The Solar Inverter converts DC voltage into AC voltage.
- 2)The enclosure assembly was secured by screws.
- 3) Dusty conditions on the unit may impair the performance of this inverter.
- 4) It is manufactured to be mounted on a wall and its degree of protection is IP65.
- 5) The ambient temperature should be between -10°C and +50°C to ensure optimal operation.
- 6) All models have the similar constructions, circuit diagram and PCB layout except model name and output power. (See below table for details) Unless otherwise stated, all tests were performed on model SNA PRO.EU 6.5K, which means the typical model.

The topology diagram as following:

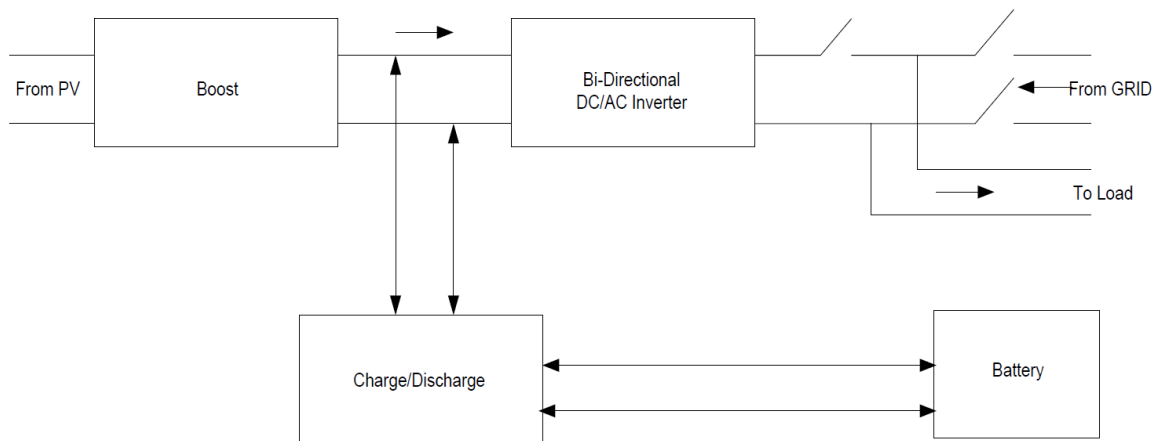

**The product was tested on:**

The Software version: CHAA-xx02

The Hardware version: E

IEC 62116			
Clause	Requirement + Test	Result - Remark	Verdict
<b>4</b>	<b>Testing circuit</b>		
	The testing circuit shown in Figure 1 is employed.		P
	Similar circuits are used for three-phase output.		P
	Parameters to be measured are shown in Table 1 and Figure 1. Parameters to be recorded in the test report are discussed in Clause 7.		P
<b>5</b>	<b>Testing equipment</b>		
<b>5.1</b>	<b>Measuring instruments</b>		
	The waveform measurement/capture device is able to record the waveform from the beginning of the islanding test until the EUT ceases to energize the island.	Waveform caught from the switch open and the EUT cease to energize	P
	For multi-phase EUT, all phases are monitored.		P
	A waveform monitor designed to detect and calculate the run-on time may be used.		P
	For multi-phase EUT, the test and measurement equipment is recorded each phase current and each phase-to-neutral or phase-to-phase voltage, as appropriate, to determine fundamental frequency active and reactive power flow over the duration of the test.		P
	A sampling rate of 10 kHz or higher is recommended. The minimum measurement accuracy is 1 % or less of rated EUT nominal output voltage and 1 % or less of rated EUT output current		P
	Current, active power, and reactive power measurements through switch S1 used to determine the circuit balance conditions report the fundamental (50 Hz or 60 Hz) component.		P
<b>5.2</b>	<b>DC power source</b>		
<b>5.2.1</b>	<b>General</b>		
	A PV array or PV array simulator (preferred) may be used. If the EUT can operate in utility-interconnected mode from a storage battery, a DC power source may be used in lieu of a battery as long as the DC power source is not the limiting device as far as the maximum EUT input current is concerned.	Topcon PV simulator used	P
	The DC power source provides voltage and current necessary to meet the testing requirements described in Clause 6.		P
<b>5.2.2</b>	<b>PV array simulator</b>		
	The tests are conducted at the input voltage defined in Table 2 below, and the current is limited to 1,5 times the rated photovoltaic input current, except when specified otherwise by the test requirements.	Topcon PV simulator used	P

IEC 62116			
Clause	Requirement + Test	Result - Remark	Verdict
	A PV array simulator is recommended, however, any type of power source may be used if it does not influence the test results.		P
<b>5.2.3</b>	<b>Current and voltage limited DC power supply with series resistance</b>		N/A
	A DC power source used as the EUT input source is capable of EUT maximum input power (so as to achieve EUT maximum output power) at minimum and maximum EUT input operating voltage.		N/A
	The power source provides adjustable current and voltage limit, set to provide the desired short circuit current and open circuit voltage when combined with the series and shunt resistance described below.		N/A
	A series resistance (and, optionally, a shunt resistance) is selected to provide a fill factor within the range: Output power: Sufficient to provide maximum EUT output power and other levels specified by test conditions of table 5. Response speed: The response time of a simulator to a step in output voltage, due to a 5% load change, results in a settling of the output current to within 10% of its final value in less than 1ms. Stability: Excluding the variations caused by the EUT MPPT, simulator output power remains stable within 2 % of specified power level over the duration of the test: from the point where load balance is achieved until the island condition is cleared or the allowable run-on time is exceeded. Power factor: 0.25 to 0.8		N/A
<b>5.2.4</b>	<b>PV array</b>		N/A
	A PV array used as the EUT input source is capable of EUT maximum input power at minimum and maximum EUT input operating voltage.		N/A
	Testing is limited to times when the irradiance varies by no more than 2 % over the duration of the test as measured by a silicon-type pyranometer or reference device. It may be necessary to adjust the array configuration to achieve the input voltage and power levels prescribed in 6.1.		N/A
<b>5.3</b>	<b>AC power source</b>		

<b>IEC 62116</b>													
Clause	Requirement + Test	Result - Remark	Verdict										
	<p>The utility grid or other AC power source may be used as long as it meets the conditions specified in Table 4.</p> <p style="text-align: center;"><b>Table 4 – AC power source requirements</b></p> <table border="1" style="width: 100%; border-collapse: collapse;"> <thead> <tr> <th style="width: 50%;">Items</th> <th style="width: 50%;">Conditions</th> </tr> </thead> <tbody> <tr> <td>Voltage</td> <td>Nominal <math>\pm 2,0</math> %</td> </tr> <tr> <td>Voltage THD</td> <td>&lt; 2,5 %</td> </tr> <tr> <td>Frequency</td> <td>Nominal <math>\pm 0,1</math> Hz</td> </tr> <tr> <td>Phase angle distance <sup>1)</sup></td> <td>120 ° <math>\pm</math> 1,5 °</td> </tr> </tbody> </table> <p><small><sup>1)</sup> Three-phase case only</small></p>	Items	Conditions	Voltage	Nominal $\pm 2,0$ %	Voltage THD	< 2,5 %	Frequency	Nominal $\pm 0,1$ Hz	Phase angle distance <sup>1)</sup>	120 ° $\pm$ 1,5 °		P
Items	Conditions												
Voltage	Nominal $\pm 2,0$ %												
Voltage THD	< 2,5 %												
Frequency	Nominal $\pm 0,1$ Hz												
Phase angle distance <sup>1)</sup>	120 ° $\pm$ 1,5 °												
<b>5.4</b>	<b>AC loads</b>												
	On the AC side of the EUT, variable resistance, capacitance, and inductance are connected in parallel as loads between the EUT and the AC power source. Other sources of load, such as electronic loads, may be used if it can be shown that the source does not cause results that are different than would be obtained with passive resistors, inductors, and capacitors.		P										
	All AC loads are rated for and adjustable to all test conditions. The equations for Qf are based upon an ideal parallel RLC circuit. For this reason, non-inductive resistors, low loss (high Qf) inductors, and capacitors with low effective series resistance and effective series inductance are utilized in the test circuit. Iron core inductors, if used, are not exceed a current THD of 2 % when operated at nominal voltage. Load components are conservatively rated for the voltage and power levels expected. Resistor power ratings are chosen so as to minimize thermally-induced drift in esistance values during the course of the test.		P										
	Active and reactive power is calculated (using the measurements provided in Table 1) in each of the R, L and C legs of the load so that these parasitic parameters (and parasitics introduced by variacs or autotransformers) are properly accounted for when calculating Qf.		P										
<b>6</b>	<b>Test for single or multi-phase inverter</b>												
<b>6.1</b>	<b>Test procedure</b>	<b>(see appended table)</b>	<b>P</b>										
	The test uses an RLC load, resonant at the EUT nominal frequency (50 Hz or 60 Hz) and matched to the EUT output power.		P										
	For multi-phase EUT, the load is balanced across all phases and the switch S1 as in Figure 1 opens all phases		P										

<b>IEC 62116</b>			
Clause	Requirement + Test	Result - Remark	Verdict
	This test is performed with the EUT conditions as in Table 5, where power and voltage values are given as a percent of EUT full output rating.		P
	a)..Determine EUT test output power		P
	b) .Adjusting the DC input source		P
	c) .Turn off the EUT and open S1		P
	d) .Adjust the RLC circuit to have $Q_f = 1.0 \pm 0.05$		P
	e)..Connect the RLC load configured in step d) to the EUT by closing S2		P
	f)...Open the utility-disconnect switch S1 to initiate the test, Run-on time is recorded.		P
	g)..For test condition A, adjust the real load and only one of the reactive load components to each of the load imbalance conditions shown in the shaded portion of table 6. If any of the recorded run-on times are longer than the one recorded for the rated balance condition, then the non-shaded parameter combinations also require testing.		P
	h) For test condition B and C, adjust the only one reactive load components by approximately 1,0% per test, within a total range of 95% to 105% of the operating point. If run-on times are still increasing at the 95% or 105% points, additional 1% increments have to be taken until run-on times begin decreasing.		P
<b>6.2</b>	<b>Pass/fail criteria</b>		
	An EUT is considered to comply with the requirements for islanding protection when each case of recorded run-on time is less than 2 s or meets the requirements of local codes.		P
<b>7</b>	<b>Documentation</b>		
	At a minimum, the following information is recorded and maintained in the test report.		P
	a) Specifications of EUT. Table 8 provides an example of the type of information that is provided.		P
	b) Measurement results. Table 9 provides an example of the type of information that is provided. Actual measured values is to be recorded.		P
	c) Block diagram of test circuit.		P
	d) Specifications of the test and measurement equipment. Table 10 provides an example of the type of information that is provided.		P
	e) Any test configuration or procedure details such as methods of achieving specified load and EUT output conditions.		P
	f) Any additional information required by the testing laboratory's accreditation.		P

IEC 62116			
Clause	Requirement + Test	Result - Remark	Verdict

	g) Specify the evaluation criterion from clause 6.2 that was utilized to determine if the product passed or failed the test.		P
Annex A	Islanding as it applies to PV systems(Informative)		--
A.1	General		--
A.2	Impact of distortion on islanding		--
Annex B	Test for independent islanding detection device (relay)(Informative)		--
B.1	Introduction		--
B.2	Testing circuit		--
B.3	Testing equipment		--
B.4	Testing procedure		--
B.5	Documentation		--

5.3		TABLE: tested condition and run-on time								P
Model: SNA PRO-EU 6.5K										
No.	P <sub>EUT</sub> (% of EUT rating)	Reactive load (% of normal)	P <sub>AC</sub>	Q <sub>AC</sub>	Run-on time(ms)	P <sub>EUT</sub> (KW)	Actual Q <sub>f</sub> (Var)	V <sub>DC</sub> (V)	Which load is selected to be adjusted (R or L)	
Test condition A										
1	100	100	0	0	319	6.5	1.002	320	/	
2	100	100	-5	-5	270	4.3	1.002	240	/	
3	100	100	-5	0	229	2.1	0.992	144	/	
4	100	100	-5	+5	136	6.5	0.978	320	/	
5	100	100	0	-5	124	6.5	0.965	320	/	
6	100	100	0	+5	139	6.5	0.942	320	/	
7	100	100	+5	-5	161	6.5	1.015	320	/	
8	100	100	+5	0	153	6.5	0.981	320	/	
9	100	100	+5	+5	161	6.5	1.073	320	/	
Test condition B										
10	66	66	0	0	292	4.3	1.023	240	/	
11	66	66	0	-5	305	4.3	1.018	240	L	
12	66	66	0	-4	338	4.3	1.013	240	L	
13	66	66	0	-3	374	4.3	1.007	240	L	
14	66	66	0	-2	317	4.3	1.007	240	L	
15	66	66	0	-1	158	4.3	0.996	240	L	
16	66	66	0	1	136	4.3	0.994	240	L	
17	66	66	0	2	162	4.3	0.989	240	L	
18	66	66	0	3	187	4.3	0.981	240	L	
19	66	66	0	4	292	4.3	0.974	240	L	
20	66	66	0	5	161	4.3	1.023	240	L	
Test condition C										
21	33	33	0	0	261	4.3	1.018	144	/	
22	33	33	0	-5	280	4.3	1.008	144	L	
23	33	33	0	-4	321	4.3	1.008	144	L	
24	33	33	0	-3	143	4.3	1.008	144	L	
25	33	33	0	-2	494	4.3	0.991	144	L	
26	33	33	0	-1	119	4.3	0.982	144	L	
27	33	33	0	1	155	4.3	0.982	144	L	
28	33	33	0	2	157	4.3	0.986	144	L	
29	33	33	0	3	169	4.3	0.969	144	L	
30	33	33	0	4	261	4.3	0.969	144	L	
31	33	33	0	5	101	4.3	1.018	144	L	
<p>Supplementary information:</p> <p>For test condition A:            If any of the recorded run-on times are longer than the one recorded for the rated balance condition, then the non-shaded parameter combinations also require testing.</p> <p>For test condition B and C:            If run-on times are still increasing at the 95 % or 105 % points, additional 1 % increments is taken until run-on times begin decreasing.</p>										



Over view

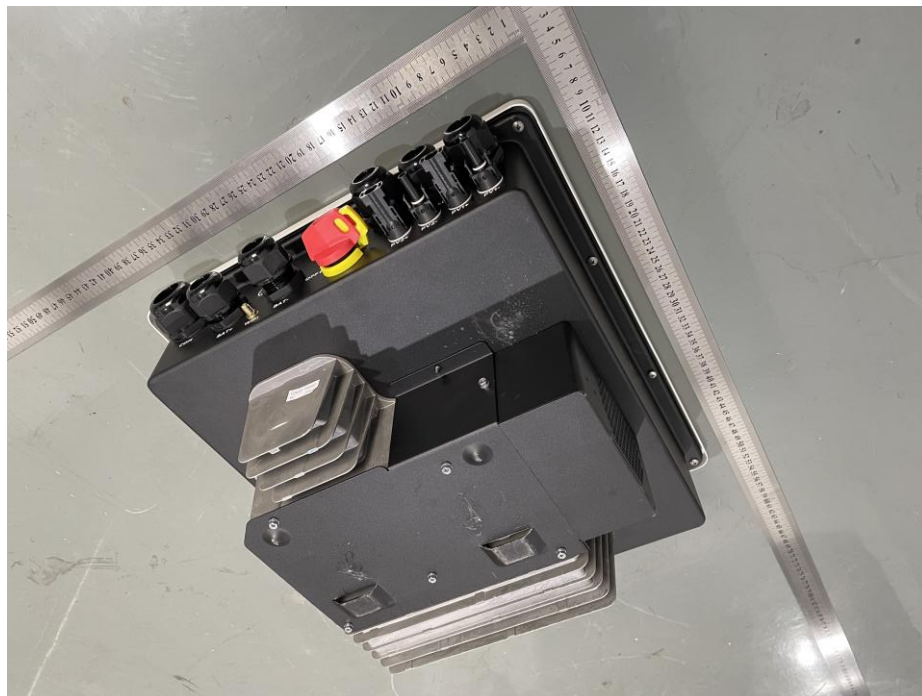

Bottom view



Connection view

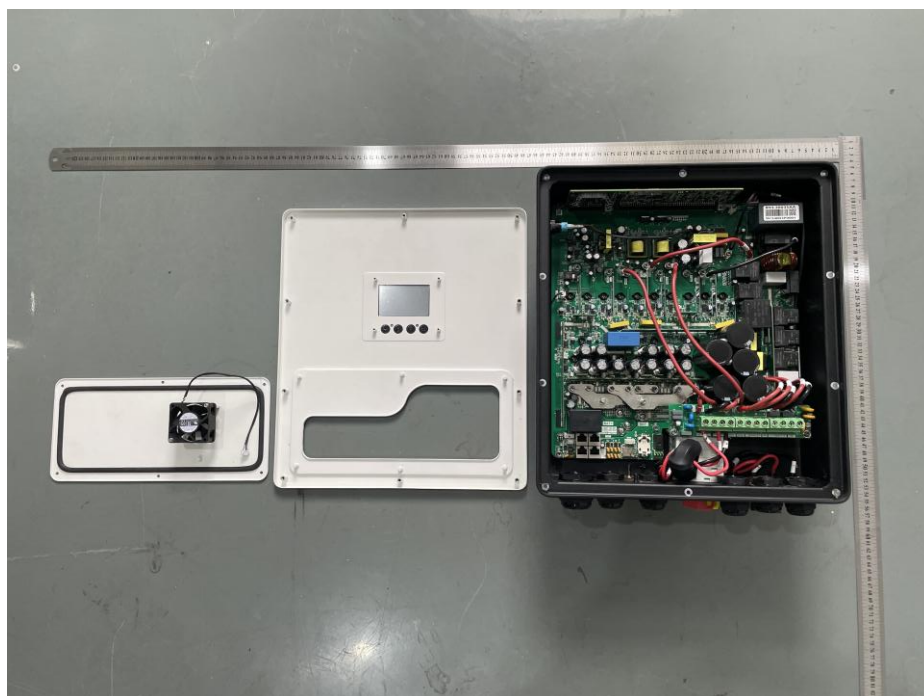

Internal view

--- End of test report--