



TL-395

Test Report issued under the responsibility of:



**TEST REPORT**  
**NRS 097-2-1:2024**  
**GRID INTERCONNECTION OF EMBEDDED GENERATION**  
**PART 2: SMALL-SCALE EMBEDDED GENERATION**  
**SECTION 1: UTILITY INTERFACE**

**Report Reference No**.....: 251027006GZU-001  
**Date of issue** .....: 06 Jan 2026  
**Total number of pages**.....: 39 pages

**Testing Laboratory** .....: Intertek Testing Services Shenzhen Ltd. Guangzhou Branch  
**Address**.....: Room101/301/401/102/202/302/402/502/602/702/802, No. 7-2, Caipin Road, Huangpu District, Guangzhou, Guangdong, China  
**Testing location/ address**.....: Same as above  
**Tested by (name + signature)** : Charlie Yang *Charlie Yang*  
 Engineer  
**Approved by (name + signature)**.....: Jason Fu *Jason Fu*  
 Supervisor

**Applicant's name** .....: Shenzhen Lux Power Technology Co., Ltd.  
**Address**.....: C501, Building A, Donghua Industrial Park, 5003 Bao'an Avenue, Sanwei Community, Hangcheng Street, Bao'an District, Shenzhen, 518126, China.

**Test specification:**  
**Standard** .....: NRS 097-2-1:2024 Edition 3  
**Test procedure**.....: Type approval  
**Non-standard test method**.....: N/A

**Test Report Form No** .....: NRS 097-2-1a  
**Test Report Form(s) Originator** .....: Intertek Guangzhou  
**Master TRF**.....: Dated 2019-05

This publication may be reproduced in whole or in part for non-commercial purposes as long as Intertek is acknowledged as copyright owner and source of the material. Intertek takes no responsibility for and will not assume liability for damages resulting from the reader's interpretation of the reproduced material due to its placement and context.

**Test item description** .....: Energy Storage Inverter  
**Trade Mark** .....: Lux Power  
**Manufacturer**.....: Same as Applicant  
**Model/Type reference**.....: SNA PRO-EU 3K, SNA PRO-EU 4K, SNA PRO-EU 5K , SNA PRO-EU 6K, SNA PRO-EU 6.5K

Ratings.....:	Model	SNA PRO-EU 3K	SNA PRO-EU 4K	SNA PRO-EU 5K	SNA PRO-EU 6K	SNA PRO-EU 6.5K
	<b>Input (PV)</b>					
	Max. input voltage	500 Vd.c.				
	MPPT voltage range	80-400 Vd.c.				
	Max. short-circuit current	25/25 Ad.c.				
	Max. input current per MPPT	20/20 Ad.c.				
	<b>Output/Input(Battery)</b>					
	Battery type	Lithium-ion/Lead-Acid				
	Battery voltage range	38.4-60 Vd.c.				
	Max. charge /discharge current	70 Ad.c.	90 Ad.c.	110 Ad.c.	135 Ad.c.	135/140 Ad.c.
	Max. charge /discharge current power	3000 W	4000 W	5000 W	6000 W	6500 W
	<b>Output/Input (On Grid)</b>					
	Rated output power	3000 W	4000 W	5000 W	6000 W	6500 W
	Rated input power	6000 W	8000 W	8000 W	9000 W	9000 W
	Max. apparent power	3000 W	4000 W	5000 W	6000 W	6500 W
	Rated output voltage	230 Va.c., L/N/PE				
	Max. output current	13 Aa.c.	17.5 Aa.c.	22 Aa.c.	26.5 Aa.c.	28.2 Aa.c.
	Max. input current	26 Aa.c.	35 Aa.c.	35 Aa.c.	39.1 Aa.c.	39.1 Aa.c.
	Rated AC grid frequency	50 Hz				

Adjustable power factor	0.9 leading-0.9 lagging				
<b>Backup parameter (AC)</b>					
Rated output power	2000 W	2000 W	2000 W	3000 W	3000 W
Max. output current	8.6 Aa.c.	8.6 Aa.c.	8.6 Aa.c.	13 Aa.c.	13 Aa.c.
Rated output voltage	230 Va.c., L/N/PE				
AC frequency	50 Hz				
<b>General Data</b>					
Safety level	Class I				
Degree of protection	IP65				
Operating temperature range	-25~60 °C (derating at 45°C)				
Software Version	CHAA-xx02				

**Summary of testing:**

**Tests performed (name of test and test clause):**

NRS 097-2-1	Test Description
4.2 & 4.5	Normal voltage operating range Normal frequency operating range
4.3	Flicker test
4.4& 5.5	DC injection DC current injection
4.6	Harmonic emissions
4.7	Power factor
4.8 & 5.6	Synchronization and reconnection Response to utility recovery
4.9*	Electromagnetic compatibility (EMC)
5.2.15& 5.2.16	Safety disconnect unit - Overvoltage and undervoltage Over-frequency and under-frequency
5.3	Prevention of forming an unintentional island on the utility side

**Testing location:**

Intertek Testing Services Shenzhen Ltd. Guangzhou Branch  
Room101/301/401/102/202/302/402/502/602/702/802,  
No. 7-2, Caipin Road, Huangpu District, Guangzhou,  
Guangdong, China

**Remark:**

For all clauses, the model PCS2000-108K-MB1 is type tested.

\*Refer to report No. ENS2502180139E00101R, tested and issued by EMTEK (SHENZHEN) CO., LTD., dated on 20 Feb. 2025.

**Copy of marking plate:**

<b>LU X POWER<sup>TEK</sup></b>	
<b>Energy Storage Inverter</b>	
<b>Model Name</b>	<b>SNA PRO-EU 6.5K</b>
<b>PV Input</b>	
Max. PV Input voltage	500d.c.V
MPPT voltage range	80-400d.c.V
Number of MPPT Inputs	2
Inputs per MPPT	2/2
Max. PV short current(Input A/B)	25d.c.A/25d.c.A
Max. PV current(Input A/B)	20d.c.A/20d.c.A
Max. PV power	12000W(6000W+6000W)
<b>AC Input</b>	
Nominal AC voltage, Frequency	230.a.c.V,50Hz/60Hz
Max. GRID Input	39.1a.c.A,9000W
Max. GEN Input	32a.c.A,7370W
Max. AC charging power to battery	6500W
<b>AC Output(Back-up)</b>	
Nominal voltage,current	230a.c.V/28.2a.c.A
Frequency	50Hz/60Hz
Nominal output power	6500W(L-N)
Output power factor	0.6~1.0
<b>Battery</b>	
Battery type	Lithium-ion/Lead-Acid
Battery voltage range	38.4d.c.V-60d.c.V
Nominal voltage	48d.c.V
Max. charge and discharge current	135d.c.A/140d.c.A
Max. charge and discharge power	6500W/6500W
<b>Environment</b>	
Altitude	<6561ft
Ingress protection rating	IP65
Protective class	I
Operating environment temperature	0-45°C
Display	LCD+LED
Communication	RS485/WIFI/CAN



Shenzhen Lux Power Technology Co., Ltd  
 C501, Building A, Donghua Industrial Park, 5003 Bao'an  
 Avenue, Sanwei Community, Hangcheng Street, Bao'an  
 District, Shenzhen, 518126, China.

**Note:**

1. The above markings are the minimum requirements required by the safety standard. For the final production samples, the additional markings which do not give rise to misunderstanding may be added.
2. Label is attached on the side surface of enclosure and visible after installation.
3. Other models same as above except rating parameters

<b>Test item particulars</b> .....	
Temperature range .....	-25~60 °C
AC Overvoltage category .....	<input type="checkbox"/> OVC I <input type="checkbox"/> OVC II <input checked="" type="checkbox"/> OVC III <input type="checkbox"/> OVC IV
DC Overvoltage category .....	<input type="checkbox"/> OVC I <input checked="" type="checkbox"/> OVC II <input type="checkbox"/> OVC III <input type="checkbox"/> OVC IV
IP protection class .....	IP65
<b>Possible test case verdicts:</b>	
- test case does not apply to the test object .....	N/A (Not applicable)
- test object does meet the requirement .....	P (Pass)
- test object does not meet the requirement .....	F (Fail)
<b>Testing</b> .....	
Date of receipt of test item .....	29 Oct. 2025
Date (s) of performance of tests .....	01 Nov. 2025 – 22 Dec. 2025
<b>General remarks:</b>	
<p>The test results presented in this report relate only to the object tested.          This report shall not be reproduced, except in full, without the written approval of the Issuing testing laboratory.          "(see Enclosure #)" refers to additional information appended to the report.          "(see appended table)" refers to a table appended to the report.</p> <p>When determining for test conclusion, measurement uncertainty of tests has been considered.          This report is for the exclusive use of Intertek's Client and is provided pursuant to the agreement between Intertek and its Client. Intertek's responsibility and liability are limited to the terms and conditions of the agreement. Intertek assumes no liability to any party, other than to the Client in accordance with the agreement, for any loss, expense or damage occasioned by the use of this report. Only the Client is authorized to permit copying or distribution of this report and then only in its entirety. Any use of the Intertek name or one of its marks for the sale or advertisement of the tested material, product or service must first be approved in writing by Intertek. The observations and test results in this report are relevant only to the sample tested. This report by itself does not imply that the material, product, or service is or has ever been under an Intertek certification program.          The test report only allows to be revised only within the report defined retention period unless standard or regulation was withdrawn or invalid.</p> <p>Throughout this report a point is used as the decimal separator.</p>	

**General product information:**

- 1)The Solar Inverter converts DC voltage into AC voltage.
- 2)The enclosure assembly was secured by screws.
- 3) Dusty conditions on the unit may impair the performance of this inverter.
- 4) It is manufactured to be mounted on a wall and its degree of protection is IP65.
- 5) The ambient temperature should be between -10'C and +50°C to ensure optimal operation.
- 6) All models have the similar constructions, circuit diagram and PCB layout except model name and output power. (See below table for details) Unless otherwise stated, all tests were performed on model SNA PRO-EU 6.5K,which means the typical model.

The topology diagram as following:

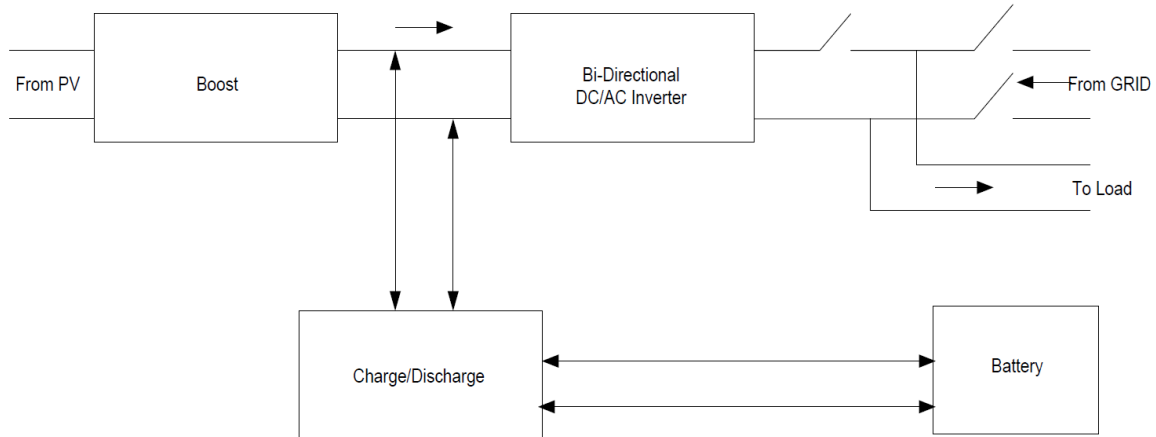

**The product was tested on:**

The Software version: CHAA-xx02

The Hardware version: E

**Factory information:**

Huizhou Jingchuangyuan Technology Co., Ltd

No.86, Hechang 7<sup>th</sup> Road (W), Zhongkai High-tech Zone, Huizhou, Guangdong, China

NRS 097-2-1:2024

Clause	Requirement - Test	Result - Remark	Verdict																																				
<b>4</b>	<b>Utility compatibility</b>		<b>P</b>																																				
<b>4.1</b>	<b>Voltage, current and frequency</b>		<b>P</b>																																				
	SSEGs shall be able to operate safely under compatibility levels defined in NRS 048-2, unless otherwise stipulated in this document.		P																																				
<b>4.2</b>	<b>Normal voltage operating range</b>		<b>P</b>																																				
<b>4.2.1</b>	SSEGs shall not control the voltage, unless agreed to by the utility. Therefore, the voltage operating range for SSEGs is designed as protection, which responds to abnormal utility network conditions and not as a voltage regulation function.		P																																				
<b>4.2.2</b>	SSEGs shall operate continuously between 85% and 110% of the nominal utility voltage as defined in the grid codes.	(See appended table)	P																																				
<b>4.3</b>	<b>Flicker</b>		<b>P</b>																																				
	Installation requirement: The short-term flicker contribution shall not exceed 0,35 as defined in NRS 048-4 that is also applicable to any other connections as stated in standard connection conditions. Should these flicker levels be exceeded, the customer shall be required to put mitigating measures in place as and when required by the utility.	(See appended table)	P																																				
<b>4.4</b>	<b>DC injection</b>		<b>P</b>																																				
	The average DC current injected by the SSEG shall never exceed 0,5% of the rated AC output current over any 1-minute period.	(See appended table)	P																																				
<b>4.5</b>	<b>Normal frequency operating range</b>		<b>P</b>																																				
	An SSEG that operates in parallel with the utility system shall operate continuously between 47 Hz and 51,5 Hz in accordance with the grid codes.	(See appended table)	P																																				
<b>4.6</b>	<b>Harmonic emissions</b>		<b>P</b>																																				
<b>4.6.1</b>	The SSEG harmonic and inter-harmonic current distortion shall comply with the relevant emission limits as defined in the grid codes for systems smaller than 5 MW and shown in Table 1.		P																																				
<b>4.6.2</b>	Total harmonic current distortion shall be less than 5% at rated inverter output. NOTE The grid codes adopted the limits in Table 1 from IEC 61727. The emission limits from the 35 <sup>th</sup> harmonic and above were obtained by dividing the column 5 limits by 2. <table border="1" data-bbox="304 1787 922 1935"> <caption>Table 1 — Maximum harmonic current distortion as percentage of rated current</caption> <thead> <tr> <th>1</th> <th>2</th> <th>3</th> <th>4</th> <th>5</th> <th>6</th> </tr> <tr> <th>Harmonic order (h)</th> <th>h&lt;11</th> <th>11Sh&lt;17</th> <th>17Sh&lt;23</th> <th>23Sh&lt;35</th> <th>35Sh≤50</th> </tr> </thead> <tbody> <tr> <td>Percentage of rated current (Odd harmonics)</td> <td>4,0</td> <td>2,0</td> <td>1,5</td> <td>0,6</td> <td>0,3</td> </tr> <tr> <td>Percentage of rated current (Even harmonics)</td> <td>1,0</td> <td>0,5</td> <td>0,38</td> <td>0,15</td> <td>0,08</td> </tr> <tr> <td colspan="6" style="text-align: center;">Total harmonic current distortion &lt; 5%</td> </tr> <tr> <td colspan="6">NOTE Even harmonics are limited to 25 % of the odd harmonic limits</td> </tr> </tbody> </table>	1	2	3	4	5	6	Harmonic order (h)	h<11	11Sh<17	17Sh<23	23Sh<35	35Sh≤50	Percentage of rated current (Odd harmonics)	4,0	2,0	1,5	0,6	0,3	Percentage of rated current (Even harmonics)	1,0	0,5	0,38	0,15	0,08	Total harmonic current distortion < 5%						NOTE Even harmonics are limited to 25 % of the odd harmonic limits						(See appended table)	P
1	2	3	4	5	6																																		
Harmonic order (h)	h<11	11Sh<17	17Sh<23	23Sh<35	35Sh≤50																																		
Percentage of rated current (Odd harmonics)	4,0	2,0	1,5	0,6	0,3																																		
Percentage of rated current (Even harmonics)	1,0	0,5	0,38	0,15	0,08																																		
Total harmonic current distortion < 5%																																							
NOTE Even harmonics are limited to 25 % of the odd harmonic limits																																							
<b>4.7</b>	<b>Power factor</b>		<b>P</b>																																				

NRS 097-2-1:2024

Clause	Requirement - Test	Result - Remark	Verdict
4.7.1	Irrespective of the number of phases to which an SSEG is connected, it shall comply with power factor requirements on each phase for normal system conditions when the output power exceeds 20% of rated active power.		P
4.7.2	Inverter based SSEGs with nominal power ratings of up to 100 Kw shall operate at a power factor of more than 0,98.		N/A
4.7.3	Installation requirement: Non-inverter based generator SSEGs with nominal power ratings of up to 100 Kw shall operate at a power factor of more than 0,98.		N/A
4.7.4	Installation requirement: Asynchronous generator based SSEGs with nominal power ratings of up to 100 Kw, which cannot control the power factor in the machine, shall reach a power factor of 0,98 within 60 s and it shall remain above 0,98.		N/A
4.7.5	Inverter based SSEGs with nominal power ratings of between 100 Kw and 1 MW shall operate at a power factor of more than 0,95.	(See appended table)	P
4.7.6	Installation requirement: Synchronous generator based SSEGs with nominal power ratings of between 100 Kw and 1 MW shall operate at a power factor of more than 0,95.		N/A
4.7.7	Installation requirement: For asynchronous generator based SSEGs with nominal power ratings between 100 Kw and 1 MW, which cannot control the power factor in the machine, the power factor shall reach the value of 0,95 within 60 s and it shall remain above 0,95.		N/A
4.8	<b>Synchronization and reconnection</b>		<b>P</b>
4.8.1	SSEGs shall connect with the utility network only when the voltage and frequency has been stable within the continuous operating ranges provided above for at least 60 seconds.	(See appended table)	P
4.8.2	Installation requirement: Synchronous generator based SSEGs shall synchronize with the utility network before the parallel connection is made.	Inverter based SSEGs	N/A
4.8.3	Installation requirement: Automatic synchronization equipment shall be the only method of synchronization for synchronous generator based SSEGs.		N/A
4.8.4	Installation requirement: For synchronous generator based SSEGs, the limits for the synchronizing parameters for each phase are: a) frequency difference: 0,3 Hz; b) voltage difference: 5% of nominal voltage per phase; and c) phase angle difference: 20° (degrees).		N/A

NRS 097-2-1:2024

Clause	Requirement - Test	Result - Remark	Verdict
4.8.5	<p>Installation requirement: Asynchronous generator based SSEGs do not need to synchronise when the generator is started as a motor before generation starts.</p> <p>NOTE: An asynchronous generator is an induction machine that is accelerated to a speed higher than synchronous speed by means of a mechanical power source on its shaft causing a negative slip and power flow into the supply.</p>		P
4.8.6	<p>Installation requirement: Asynchronous generator based SSEGs shall be soft started when the start-up voltage change is anticipated to be more than 3%.</p>		N/A
4.8.7	<p>The start-up current for inverter based SSEGs shall not exceed the full power rated current of the generator.</p> <p>NOTE: Inverter based SSEGs connect to the utility supply before producing an AC current that is in phase with the utility voltage. This synchronized current typically ramps up from zero amplitude during the start-up process.</p>		P
4.9	<b>Electromagnetic compatibility (EMC)</b>	Refer to report No. ENS2511120219E00101R , tested and issued by EMTEK (SHENZHEN) CO., LTD., dated on .	P
<b>5</b>	<b>Safety and protection</b>		<b>P</b>
<b>5.1</b>	<b>General</b>		P
5.1.1	SSEGs shall not cause safety hazards to people that include the owners (including personnel and inhabitants of the property) of the SSEG, general public, network operators and general emergency response personnel.		P
5.1.2	SSEGs shall not cause safety hazards to equipment that include utility equipment, other customers' equipment connected to the same network and owners' equipment.		P
<b>5.2</b>	<b>Safety disconnect unit</b>		P
	NOTE: The safety disconnect unit's (SDU) purpose is to protect the installation and the network from personal and equipment safety hazards.		P
5.2.1	SSEGs shall be equipped with SDUs that separate the SSEGs from the grid due to abnormal conditions for protection of the installation and the network.		P
5.2.2	Abnormal conditions for inverter based SSEGs shall include network voltage or frequency out-of-bounds conditions, DC current injection threshold exceedance, and residual DC current threshold exceeded.		P
5.2.3	Abnormal conditions for non-inverter based SSEGs shall include network voltage or frequency out-of-bounds conditions.		N/A

NRS 097-2-1:2024

Clause	Requirement - Test	Result - Remark	Verdict
5.2.4	Inverter-based SSEGs shall have SDUs in each unit and shall be SANS/IEC 62109-1 and SANS/IEC 62109-2 certified.	Refer to reports are requested by IEC 62109-1 and IEC 62109-2	P
5.2.5	Installation requirement: Non-inverter based SSEGs shall be equipped with external electromechanical SDUs with switches that are SANS/IEC 60947-1 and SANS/IEC 60947-4-1 certified. NOTE: Some of the requirements for SDUs in the standards referenced above are listed below to emphasize importance. All applicable requirements in these standards shall be met.		N/A
5.2.6	The SDUs shall be able to operate under all operating conditions of the utility network.		P
5.2.7	A failure within the SDU shall lead to disconnection of the generator from the utility supply and indication of the failure condition.		P
5.2.8	A single failure within the SDU shall not lead to failure to disconnect. Failures with one common cause shall be taken into account and addressed through adequate redundancy.		P
5.2.9	The SDU shall disconnect a generator without simple separation, from the network by means of two series connected robust electromechanical switches on each current carrying conductor, including the neutral.		P
5.2.10	The SDU shall disconnect a generator with simple separation, from the network by means of one series connected robust electromechanical switch on each current carrying conductor, including the neutral. NOTE: The switching unit needs not to disconnect its sensing circuits.		P
5.2.11	The current breaking capacity of each disconnecting switch shall be rated at the nominal current rating of the inverter.		P
5.2.12	The total clearance between the inverter AC conductors and the grid conductors when the SDU is switched off, shall be in accordance with SANS/IEC 62109-1 and SANS/IEC 62109-2.	Refer to reports are requested by IEC 62109-1 and IEC 62109-2	P
5.2.13	Any programmable parameters of SDU shall be protected from interference by third parties, i.e., password protected or access physically sealed. NOTE: In a hybrid system, the SSEG is allowed to form an intentional island to supply loads after disconnecting from the grid.		P
5.2.14	Installation requirement: The SDUs of non-inverter based SSEGs shall be equipped with protection relays that are VDE 0126-1-1 certified.		N/A

Clause	Requirement - Test	Result - Remark	Verdict																						
5.2.15	<p>The protection functions and response times in Table 3 shall be applied to all SSEGs.</p> <p style="text-align: center;"><b>Table 3 — Protection functions and response times</b></p> <table border="1" style="width: 100%; border-collapse: collapse;"> <thead> <tr> <th style="width: 50%; text-align: center;">1</th> <th style="width: 50%; text-align: center;">2</th> </tr> <tr> <th style="text-align: left;">Protection function</th> <th style="text-align: left;">Maximum trip time</th> </tr> </thead> <tbody> <tr> <td>V &lt; 50 %</td> <td>0,2 s</td> </tr> <tr> <td>50 % ≤ V &lt; 85 %</td> <td>10 s</td> </tr> <tr> <td>85 % ≤ V ≤ 110 %</td> <td>Continuous operation</td> </tr> <tr> <td>110 % &lt; V &lt; 115 %</td> <td>40 s</td> </tr> <tr> <td>115% ≤ V &lt; 120%</td> <td>2 s</td> </tr> <tr> <td>120 % ≤ V</td> <td>0,16 s</td> </tr> <tr> <td>f &lt; 47 Hz</td> <td>0,2 s</td> </tr> <tr> <td>f &gt; 51,5 Hz</td> <td>4 s</td> </tr> <tr> <td>RoCoF &gt; 1,5 Hz/s</td> <td>2 s</td> </tr> </tbody> </table> <p><small>NOTE It can be assumed that the electromechanical switch will operate within 0,1 s after receiving a signal from the protection relay. The protection function should therefore be set to respond 0,1 s faster than the maximum trip times.</small></p>	1	2	Protection function	Maximum trip time	V < 50 %	0,2 s	50 % ≤ V < 85 %	10 s	85 % ≤ V ≤ 110 %	Continuous operation	110 % < V < 115 %	40 s	115% ≤ V < 120%	2 s	120 % ≤ V	0,16 s	f < 47 Hz	0,2 s	f > 51,5 Hz	4 s	RoCoF > 1,5 Hz/s	2 s	(See appended table)	P
1	2																								
Protection function	Maximum trip time																								
V < 50 %	0,2 s																								
50 % ≤ V < 85 %	10 s																								
85 % ≤ V ≤ 110 %	Continuous operation																								
110 % < V < 115 %	40 s																								
115% ≤ V < 120%	2 s																								
120 % ≤ V	0,16 s																								
f < 47 Hz	0,2 s																								
f > 51,5 Hz	4 s																								
RoCoF > 1,5 Hz/s	2 s																								
5.2.16	The permissible tolerance between the setting value and the tripping value is a maximum of ±1% of nominal for the voltage and of ±0,1% of nominal for the frequency.		P																						
5.3	<b>Prevention of forming an unintentional island on the utility side</b>		P																						
5.3.1	An islanding condition shall cause the SSEG to cease to energize the utility network within 2 s, irrespective of connected loads or other SSEGs.		P																						
5.3.2	All inverter based SSEGs shall incorporate passive or active island detection methods.		P																						
5.3.3	Islanding detection method of inverter based SSEGs shall be tested according to and must comply with IEC 62116.		P																						
5.3.4	Installation requirement: Non inverter based SSEGs shall use the rate of change of frequency (RoCoF) measurement for island detection.		N/A																						
5.3.5	Installation requirement: The RoCoF protection function for non inverter based SSEGs shall be incorporated in the SDU with a trip level of 1,5 Hz/s as listed in Table 3.		N/A																						
5.3.6	The SSEG shall physically disconnect from the utility network in accordance with the requirements of the SDU.		P																						
5.4	<b>Neutral to earth bonding when forming an intentional island</b>		N/A																						
5.4.1	To prevent a SSEG neutral connection to the the utility neutral through an earth conductor when the SDU opens, the SSEG shall not have a permanent neutral bonding to earth.		N/A																						
5.4.2	A hybrid system intended to form an intentional island on the load side during utility supply interruption shall open the SDU to prevent unintentional island on the utility side.		N/A																						

NRS 097-2-1:2024

Clause	Requirement - Test	Result - Remark	Verdict
5.4.3	Since the SDU opens the neutral on the utility side, the intentional island neutral shall be bonded to earth within 200 ms after the SDU operation using a neutral to earth bonding unit (NEB).		N/A
5.4.4	The NEB shall open within a time period of 200 ms before the SDU reconnects the inverter to the utility supply.		N/A
5.4.5	The NEB shall consist of an electromechanical switching device rated at the nominal current rating of the inverter.		N/A
5.4.6	The total clearance between the inverter neutral and earth conductors when the NEB is switched off, shall be equal the clearance of the SDU in its open state or more.		N/A
5.4.7	The NEB shall be an internal inverter component or an external device that is activated by a dedicated control port of the inverter.		N/A
5.4.8	The inverter data sheets shall indicate that it contains an internal NEB or a dedicated NEB control port for external devices.		N/A
5.5	<b>DC current injection</b>		<b>P</b>
	Inverter based SSEGs shall open their SDUs within 500 ms if the threshold for DC current injection is exceeded.	(See appended table)	P
5.6	<b>Response to utility recovery</b>		<b>P</b>
	All SSEGs shall respond to utility recovery according to the synchronization and reconnection requirements in Section 4.8.	(See appended table)	P
5.7	<b>Isolation</b>		<b>N/A</b>
5.7.1	Installation requirement: As prescribed by SANS 10142-1, each energy source shall have its own, appropriately rated, isolation device. The disconnecting device may be a circuit-breaker with the property of disconnection, or a switch-disconnector.	Shall consider in the end installation	N/A
5.7.2	Installation requirement: The installation shall provide a means of isolating from the utility interface to allow for safe maintenance. The disconnection device shall be a double pole for a singlephase SSEG, a three-pole for a three-phase delta-connected SSEG, and a four-pole for a three-phase star-connected SSEG. The grid supply side shall be wired as the source.		N/A
5.7.3	Installation requirement: The breaking capacity of the isolation circuit-breaker closest to the SSEG shall be rated appropriately for the isolation point in accordance with SANS/IEC 60947-2 and SANS/IEC 60947-3. This disconnection device does not need to be accessible to the utility.		N/A
5.8	<b>Earthing</b>		<b>P</b>
5.8.1	<b>Earthing Installation requirements</b>		P

NRS 097-2-1:2024			
Clause	Requirement - Test	Result - Remark	Verdict
5.8.1.1	The electrical installation shall be earthed in accordance with SANS 10142-1.	Shall consider in the end installation	N/A
5.8.1.2	Installations with inverter based SSEGs without simple separation shall make use of integrated earth leakage protection able to respond to DC fault currents according to SANS/IEC 62109-2.	Shall consider in the end installation	N/A
5.9	<b>Short-circuit protection</b>		<b>N/A</b>
5.9.1	Installation requirement: The SSEG shall have suitably rated short-circuit protection at the connection to the AC mains in accordance with SANS 10142-1.	Shall consider in the end installation	N/A
5.9.2	Installation requirement: The short-circuit characteristics of the SSEG shall be provided to the utility on request.		N/A
5.10	<b>Labelling</b>		<b>P</b>
5.10.1	Installation requirement: A label on the distribution board of the premises where the SSEG is connected shown in Figure 1, shall state: "WARNING: ON-SITE EMBEDDED GENERATION. DO NOT WORK ON THIS EQUIPMENT UNTIL IT IS ISOLATED FROM BOTH MAINS AND ON-SITE GENERATION SUPPLIES." Or similar warning. Disconnection points for all supplies shall be indicated.		P
5.10.2	Installation requirement: The label shall be permanent with lettering of height at least 8 mm.		P
5.10.3	Installation requirement: The label shall comply to requirements of SABS 1186-1.		P
6	<b>Metering</b>		<b>N/A</b>

**Appended Table – Testing Result**

<p><b>4.2</b> <b>4.5</b></p>	<p><b>Table: Normal voltage operating range</b> <b>Normal frequency operating range</b></p>	<p><b>P</b></p>
<p><b>Normal operating at 0.85Vn 47Hz</b></p>		
<p>The graph displays three data series over a 600-second period. The voltage (U) remains constant at approximately 0.855 p.u. The power (P) fluctuates slightly around 0.975 p.u. The frequency (Freq) is constant at 47 Hz.</p>		
<p><b>Normal operating at 1.1Vn 51.5Hz</b></p>		
<p>The graph displays three data series over a 300-second period. The voltage (U) is constant at approximately 1.1 p.u. The power (P) is constant at 1.0 p.u. The frequency (Freq) is constant at 51.5 Hz.</p>		

<b>4.3</b>	<b>Table: Flicker test</b>	<b>P</b>
$P_n(\%)$	<b>100%</b>	<b>Limit</b>
PST	0.184	$\leq 0.35$
PLT	0.172	$\leq 0.30$

Note:

Network strength:  $Z_{source} = 1.05 + j 0.32 \text{ ohm}$

100%										
AC										
Phase 1 judgement: Pass					Total judgement: Pass					
限制	3.300	dc [%]	4.000	dmax [%]	0.500	td [s]	1.000	Pst	0.650	Plt
Result	0.519	Pass	0.822	Pass	0.000	Pass	0.184	Pass	0.172	Pass
1	0.519	Pass	0.681	Pass	0.000	Pass	0.139	Pass		
2	0.489	Pass	0.621	Pass	0.000	Pass	0.138	Pass		
3	0.496	Pass	0.689	Pass	0.000	Pass	0.176	Pass		
4	0.498	Pass	0.749	Pass	0.000	Pass	0.181	Pass		
5	0.490	Pass	0.801	Pass	0.000	Pass	0.174	Pass		
6	0.490	Pass	0.693	Pass	0.000	Pass	0.180	Pass		
7	0.497	Pass	0.682	Pass	0.000	Pass	0.175	Pass		
8	0.496	Pass	0.722	Pass	0.000	Pass	0.175	Pass		
9	0.491	Pass	0.759	Pass	0.000	Pass	0.184	Pass		
10	0.490	Pass	0.822	Pass	0.000	Pass	0.178	Pass		
11	0.493	Pass	0.703	Pass	0.000	Pass	0.178	Pass		
12	0.489	Pass	0.750	Pass	0.000	Pass	0.177	Pass		

4.4	Table: DC injection			P
Pn[%]	25%Pn	50%Pn	100%Pn	Limited
d.c. current measured result (A) (max. value)	0.012	0.014	0.025	±0.783

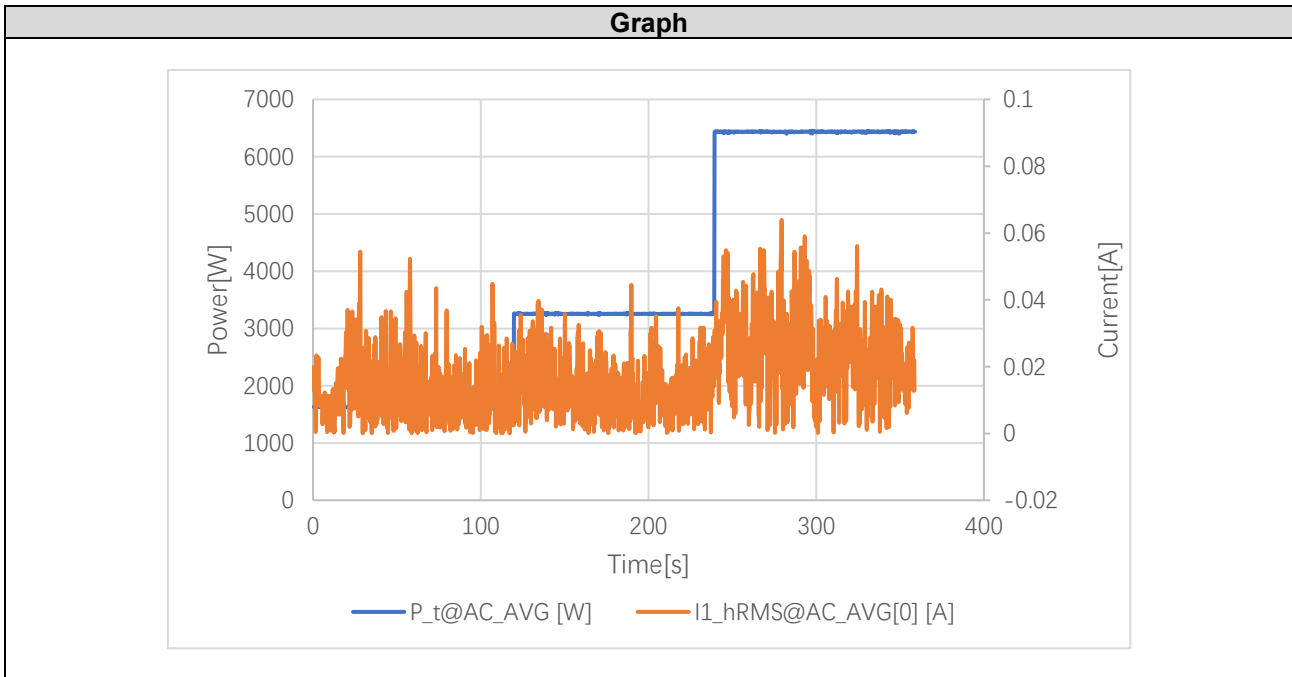

<b>5.5</b>	<b>Table: DC current injection</b>			<b>P</b>
<b>Measured protection time when d.c. current over 0.5%In</b>				
<b>Pn[%]</b>	<b>33%Pn</b>	<b>66%Pn</b>	<b>100%Pn</b>	<b>Limited</b>
<b>Disconnect on time(ms)</b>	431	437	459	500

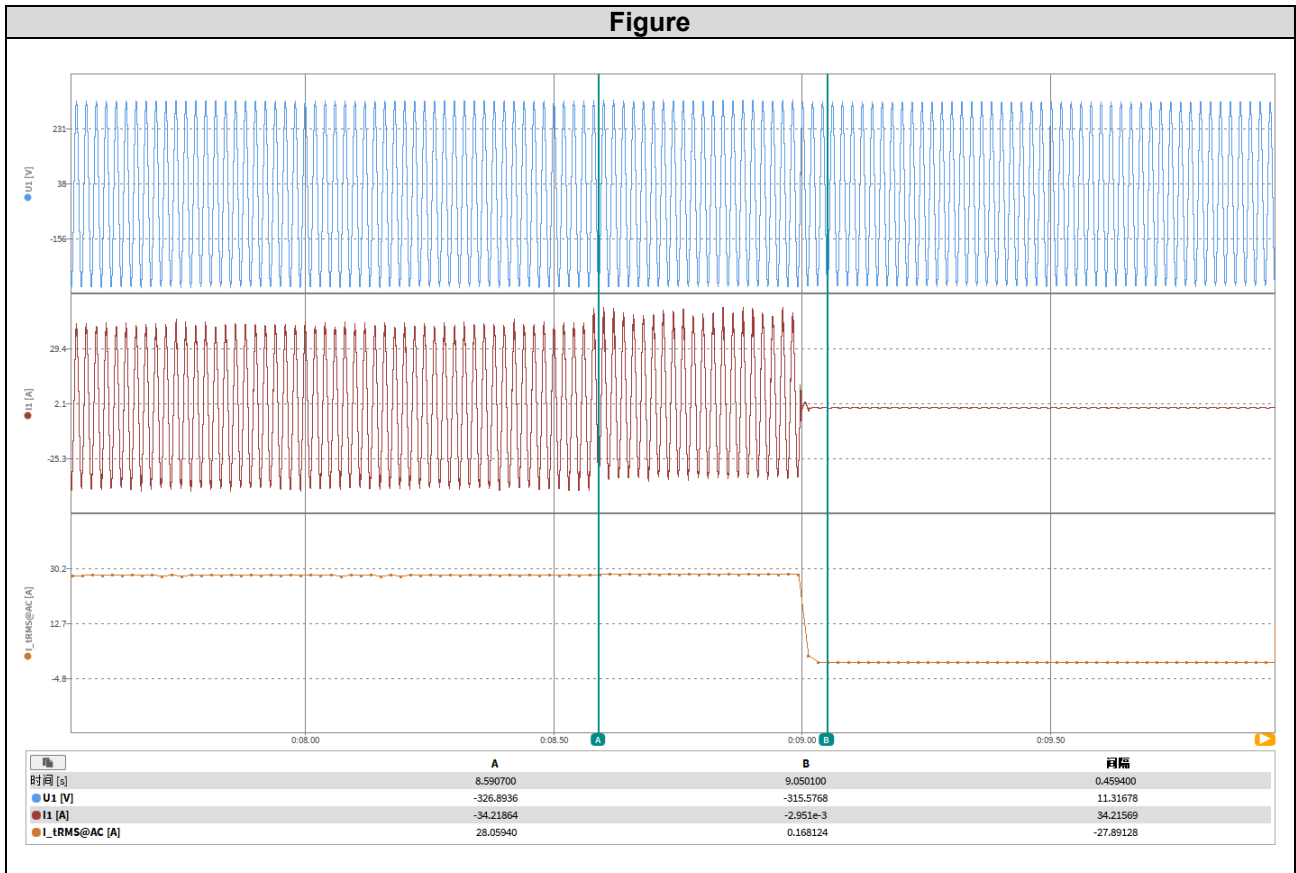

4.6	Table: Harmonic emissions					P
<b>Table 1 — Maximum harmonic current distortion as percentage of rated current</b>						
1	2	3	4	5	6	
Harmonic order (h)	<b>h&lt;11</b>	<b>11≤h&lt;17</b>	<b>17≤h&lt;23</b>	<b>23≤h&lt;35</b>	<b>35≤h≤50</b>	
Percentage of rated current (Odd harmonics)	4,0	2,0	1,5	0,6	0,3	
Percentage of rated current (Even harmonics)	1,0	0,5	0,38	0,15	0,08	
Total harmonic current distortion < 5%						
NOTE Even harmonics are limited to 25 % of the odd harmonic limits						

L1 (230/400V)												LIMIT (%)
Pn(%)	0	10	20	30	40	50	60	70	80	90	100	
Nr. /Order	I <sub>n</sub> (%)	I <sub>n</sub> (%)	I <sub>n</sub> (%)	I <sub>n</sub> (%)	I <sub>n</sub> (%)	I <sub>n</sub> (%)	I <sub>n</sub> (%)	I <sub>n</sub> (%)	I <sub>n</sub> (%)	I <sub>n</sub> (%)	I <sub>n</sub> (%)	
2	0.020	0.039	0.085	0.108	0.114	0.123	0.111	0.123	0.224	0.493	0.353	1
3	0.283	0.426	0.586	0.694	0.795	0.891	0.976	1.104	1.234	1.386	1.486	4
4	0.018	0.103	0.139	0.196	0.254	0.297	0.306	0.328	0.415	0.517	0.386	1
5	0.349	0.369	0.327	0.295	0.284	0.281	0.245	0.240	0.269	0.457	0.513	4
6	0.034	0.018	0.015	0.041	0.072	0.067	0.038	0.051	0.076	0.045	0.103	1
7	0.093	0.082	0.187	0.192	0.214	0.220	0.207	0.178	0.197	0.146	0.138	4
8	0.021	0.012	0.020	0.036	0.043	0.035	0.049	0.140	0.217	0.177	0.135	1
9	0.086	0.061	0.108	0.153	0.171	0.178	0.214	0.278	0.341	0.325	0.312	4
10	0.019	0.021	0.027	0.014	0.025	0.041	0.016	0.082	0.178	0.113	0.048	1
11	0.018	0.065	0.069	0.107	0.135	0.164	0.179	0.145	0.134	0.146	0.175	2
12	0.019	0.013	0.032	0.031	0.019	0.013	0.021	0.084	0.210	0.197	0.081	0.5
13	0.053	0.039	0.040	0.090	0.127	0.137	0.159	0.202	0.293	0.341	0.351	2
14	0.023	0.046	0.051	0.058	0.056	0.034	0.046	0.073	0.088	0.196	0.132	0.5
15	0.022	0.034	0.045	0.071	0.111	0.131	0.170	0.213	0.204	0.194	0.203	2
16	0.018	0.029	0.036	0.044	0.061	0.095	0.158	0.238	0.197	0.048	0.044	0.5
17	0.025	0.025	0.046	0.074	0.099	0.091	0.087	0.126	0.142	0.111	0.127	1.5
18	0.008	0.013	0.011	0.011	0.010	0.015	0.045	0.108	0.179	0.157	0.068	0.38
19	0.025	0.023	0.021	0.037	0.056	0.081	0.110	0.137	0.203	0.273	0.286	1.5
20	0.009	0.015	0.014	0.024	0.046	0.079	0.089	0.053	0.063	0.190	0.143	0.38
21	0.011	0.025	0.032	0.043	0.069	0.111	0.157	0.164	0.161	0.108	0.090	1.5
22	0.010	0.017	0.036	0.047	0.062	0.095	0.154	0.180	0.149	0.044	0.065	0.38
23	0.019	0.033	0.030	0.053	0.074	0.079	0.091	0.124	0.118	0.044	0.054	0.6
24	0.015	0.034	0.052	0.065	0.077	0.073	0.051	0.103	0.150	0.143	0.080	0.15
25	0.020	0.031	0.041	0.049	0.064	0.074	0.041	0.037	0.128	0.197	0.195	0.6
26	0.011	0.013	0.020	0.019	0.031	0.067	0.088	0.077	0.079	0.141	0.139	0.15
27	0.021	0.038	0.029	0.039	0.032	0.035	0.088	0.137	0.141	0.089	0.064	0.6
28	0.015	0.021	0.031	0.044	0.054	0.043	0.041	0.087	0.136	0.052	0.059	0.15
29	0.044	0.067	0.071	0.089	0.095	0.110	0.119	0.095	0.071	0.101	0.098	0.6
30	0.023	0.040	0.057	0.076	0.110	0.144	0.150	0.137	0.074	0.091	0.096	0.15
31	0.053	0.070	0.079	0.091	0.064	0.051	0.052	0.060	0.094	0.092	0.131	0.6
32	0.022	0.037	0.055	0.078	0.096	0.086	0.062	0.055	0.076	0.054	0.059	0.15
33	0.056	0.062	0.054	0.031	0.048	0.071	0.065	0.060	0.068	0.072	0.162	0.6
34	0.010	0.018	0.024	0.024	0.043	0.065	0.072	0.071	0.107	0.131	0.070	0.15
35	0.036	0.053	0.033	0.029	0.029	0.032	0.037	0.036	0.055	0.214	0.225	0.3
36	0.010	0.016	0.037	0.047	0.054	0.047	0.062	0.075	0.069	0.022	0.035	0.08
37	0.044	0.048	0.042	0.048	0.051	0.041	0.059	0.117	0.216	0.123	0.124	0.3
38	0.011	0.011	0.021	0.023	0.026	0.043	0.048	0.031	0.077	0.051	0.071	0.08
39	0.031	0.026	0.045	0.051	0.055	0.069	0.110	0.116	0.123	0.142	0.112	0.3
40	0.009	0.012	0.018	0.024	0.025	0.021	0.033	0.061	0.065	0.074	0.066	0.08
41	0.026	0.040	0.042	0.036	0.044	0.044	0.038	0.062	0.048	0.157	0.191	0.3
42	0.009	0.017	0.021	0.029	0.055	0.057	0.072	0.075	0.061	0.057	0.050	0.08
43	0.012	0.013	0.024	0.020	0.020	0.029	0.055	0.045	0.065	0.179	0.249	0.3
44	0.008	0.013	0.013	0.019	0.031	0.029	0.025	0.046	0.023	0.080	0.068	0.08
45	0.010	0.016	0.016	0.016	0.020	0.040	0.057	0.081	0.144	0.153	0.200	0.3
46	0.010	0.010	0.010	0.014	0.015	0.015	0.020	0.039	0.080	0.045	0.022	0.08
47	0.015	0.017	0.032	0.042	0.041	0.043	0.045	0.044	0.053	0.119	0.201	0.3
48	0.011	0.014	0.016	0.020	0.024	0.029	0.033	0.033	0.058	0.144	0.181	0.08
49	0.009	0.019	0.033	0.027	0.017	0.028	0.046	0.057	0.038	0.115	0.168	0.3
50	0.009	0.021	0.021	0.021	0.020	0.013	0.032	0.050	0.046	0.058	0.017	0.08
THD(%)	0.494	0.622	0.765	0.885	1.015	1.133	1.239	1.412	1.654	1.936	1.974	5

L1 (230/400V)												P
Active power P/Pn [%]	0	10	20	30	40	50	60	70	80	90	100	LIMIT
Frequency [Hz]	[%]	[%]	[%]	[%]	[%]	[%]	[%]	[%]	[%]	[%]	[%]	(%)
75	0.041	0.083	0.074	0.080	0.087	0.093	0.098	0.099	0.087	0.068	0.001	0.1
125	0.018	0.032	0.030	0.031	0.042	0.041	0.036	0.043	0.049	0.067	0.001	0.1
175	0.017	0.023	0.025	0.024	0.032	0.028	0.031	0.030	0.040	0.046	0.001	0.1
225	0.019	0.020	0.022	0.022	0.027	0.027	0.026	0.027	0.032	0.038	0.000	0.1
275	0.018	0.021	0.021	0.021	0.025	0.024	0.024	0.025	0.031	0.038	0.000	0.1
325	0.015	0.020	0.021	0.022	0.025	0.026	0.026	0.026	0.031	0.036	0.000	0.1
375	0.015	0.021	0.022	0.024	0.027	0.028	0.028	0.030	0.034	0.040	0.000	0.1
425	0.016	0.027	0.025	0.029	0.031	0.035	0.037	0.039	0.041	0.045	0.001	0.1
475	0.016	0.026	0.025	0.029	0.032	0.034	0.036	0.039	0.042	0.046	0.001	0.1
525	0.012	0.023	0.021	0.023	0.026	0.028	0.029	0.030	0.034	0.039	0.000	0.1
575	0.012	0.022	0.020	0.021	0.023	0.023	0.025	0.025	0.030	0.035	0.000	0.25
625	0.015	0.023	0.020	0.022	0.024	0.025	0.027	0.028	0.033	0.038	0.000	0.25
675	0.015	0.026	0.025	0.027	0.030	0.031	0.033	0.035	0.041	0.047	0.001	0.25
725	0.019	0.032	0.032	0.035	0.041	0.043	0.046	0.049	0.055	0.062	0.001	0.25
775	0.020	0.033	0.031	0.034	0.040	0.042	0.046	0.048	0.054	0.063	0.001	0.25
825	0.015	0.031	0.025	0.027	0.031	0.033	0.036	0.039	0.044	0.052	0.001	0.25
875	0.015	0.032	0.023	0.024	0.028	0.030	0.032	0.035	0.042	0.046	0.001	0.19
925	0.015	0.032	0.022	0.023	0.027	0.029	0.032	0.033	0.040	0.044	0.001	0.19
975	0.015	0.034	0.021	0.022	0.026	0.028	0.031	0.034	0.041	0.046	0.001	0.19
1025	0.015	0.034	0.021	0.022	0.026	0.028	0.031	0.034	0.041	0.046	0.001	0.19
1075	0.014	0.036	0.020	0.021	0.024	0.027	0.030	0.033	0.040	0.046	0.001	0.19
1125	0.014	0.039	0.019	0.020	0.024	0.026	0.028	0.032	0.039	0.044	0.001	0.19
1175	0.014	0.042	0.018	0.019	0.022	0.025	0.027	0.030	0.038	0.043	0.001	0.08
1225	0.013	0.045	0.017	0.018	0.021	0.022	0.025	0.028	0.034	0.040	0.001	0.08
1275	0.013	0.047	0.016	0.017	0.019	0.021	0.022	0.025	0.032	0.037	0.001	0.08
1325	0.012	0.048	0.015	0.015	0.018	0.019	0.020	0.023	0.029	0.035	0.000	0.08
1375	0.012	0.045	0.015	0.015	0.017	0.018	0.020	0.022	0.029	0.033	0.000	0.08
1425	0.012	0.042	0.015	0.015	0.017	0.018	0.019	0.022	0.028	0.032	0.000	0.08
1475	0.012	0.037	0.015	0.015	0.017	0.018	0.020	0.023	0.028	0.033	0.000	0.08
1525	0.012	0.034	0.014	0.015	0.017	0.018	0.020	0.023	0.028	0.033	0.000	0.08
1575	0.012	0.031	0.014	0.014	0.016	0.018	0.019	0.023	0.028	0.032	0.000	0.08
1625	0.012	0.030	0.013	0.014	0.016	0.017	0.019	0.022	0.027	0.032	0.000	0.08
1675	0.011	0.029	0.013	0.013	0.014	0.015	0.017	0.021	0.025	0.029	0.000	0.08
1725	0.011	0.028	0.013	0.013	0.014	0.015	0.016	0.020	0.023	0.028	0.000	0.08
1775	0.011	0.026	0.013	0.013	0.014	0.015	0.016	0.019	0.022	0.026	0.000	0.03
1825	0.011	0.025	0.012	0.013	0.014	0.015	0.016	0.019	0.021	0.026	0.000	0.03
1875	0.026	0.028	0.025	0.023	0.026	0.027	0.028	0.027	0.025	0.023	0.000	0.03
1925	0.011	0.023	0.012	0.012	0.014	0.014	0.015	0.019	0.021	0.026	0.000	0.03
1975	0.011	0.021	0.012	0.012	0.013	0.014	0.015	0.019	0.021	0.026	0.000	0.03
2025	0.011	0.018	0.011	0.012	0.013	0.014	0.015	0.018	0.020	0.025	0.000	0.03
2075	0.011	0.017	0.011	0.012	0.013	0.014	0.014	0.018	0.019	0.025	0.000	0.03

2125	0.011	0.015	0.011	0.011	0.012	0.013	0.013	0.017	0.018	0.023	0.000	0.03
2175	0.011	0.014	0.011	0.011	0.012	0.012	0.013	0.016	0.017	0.023	0.000	0.03
2225	0.011	0.013	0.011	0.011	0.012	0.012	0.013	0.016	0.017	0.022	0.000	0.03
2275	0.010	0.013	0.011	0.010	0.012	0.012	0.013	0.017	0.017	0.023	0.000	0.03
2325	0.011	0.012	0.011	0.011	0.013	0.013	0.014	0.017	0.018	0.023	0.000	0.03
2375	0.012	0.013	0.012	0.012	0.013	0.014	0.016	0.018	0.018	0.024	0.000	0.03
2425	0.012	0.012	0.011	0.011	0.013	0.013	0.015	0.017	0.018	0.023	0.000	0.03
2475	0.010	0.011	0.011	0.011	0.012	0.012	0.014	0.017	0.017	0.022	0.000	0.03
2525	0.010	0.011	0.010	0.010	0.011	0.012	0.014	0.016	0.016	0.022	0.000	0.03
2575	0.011	0.010	0.010	0.010	0.011	0.012	0.013	0.016	0.016	0.021	0.000	0.03
2625	0.010	0.010	0.010	0.010	0.011	0.012	0.014	0.016	0.016	0.021	0.000	0.03
2675	0.011	0.010	0.010	0.010	0.011	0.012	0.014	0.017	0.017	0.021	0.000	0.03
2725	0.011	0.009	0.010	0.010	0.011	0.012	0.014	0.016	0.016	0.020	0.000	0.03
2775	0.009	0.009	0.010	0.010	0.011	0.011	0.014	0.015	0.015	0.020	0.000	0.03
2825	0.009	0.009	0.009	0.009	0.010	0.011	0.013	0.015	0.015	0.019	0.000	0.03
2875	0.009	0.008	0.009	0.009	0.010	0.010	0.013	0.015	0.015	0.019	0.000	0.03
2925	0.009	0.008	0.009	0.009	0.010	0.010	0.013	0.014	0.014	0.017	0.000	0.03
2975	0.009	0.008	0.009	0.009	0.009	0.010	0.013	0.014	0.014	0.017	0.000	0.03
3025	0.009	0.008	0.009	0.009	0.010	0.010	0.014	0.014	0.015	0.017	0.000	0.03

L1 (230/400V)											
Active power P/Pn [%]	0	10	20	30	40	50	60	70	80	90	100
Frequency [kHz]	[%]	[%]	[%]	[%]	[%]	[%]	[%]	[%]	[%]	[%]	[%]
2.1	0.762%	0.636%	0.349%	0.257%	0.212%	0.178%	0.146%	0.129%	0.117%	0.121%	0.091%
2.3	0.888%	0.548%	0.330%	0.241%	0.167%	0.138%	0.117%	0.115%	0.101%	0.100%	0.081%
2.5	0.580%	0.332%	0.249%	0.197%	0.142%	0.123%	0.104%	0.104%	0.097%	0.102%	0.079%
2.7	0.365%	0.266%	0.197%	0.131%	0.099%	0.094%	0.084%	0.083%	0.074%	0.086%	0.080%
2.9	0.309%	0.256%	0.212%	0.144%	0.116%	0.103%	0.093%	0.091%	0.082%	0.080%	0.067%
3.1	0.256%	0.220%	0.171%	0.134%	0.113%	0.110%	0.103%	0.099%	0.091%	0.096%	0.076%
3.3	0.180%	0.168%	0.125%	0.121%	0.101%	0.094%	0.101%	0.102%	0.095%	0.097%	0.098%
3.5	0.150%	0.151%	0.117%	0.105%	0.085%	0.085%	0.089%	0.103%	0.107%	0.106%	0.106%
3.7	0.148%	0.141%	0.113%	0.107%	0.092%	0.087%	0.084%	0.087%	0.094%	0.103%	0.106%
3.9	0.142%	0.142%	0.101%	0.088%	0.074%	0.077%	0.080%	0.081%	0.079%	0.084%	0.095%
4.1	0.163%	0.173%	0.103%	0.086%	0.070%	0.064%	0.062%	0.064%	0.065%	0.068%	0.071%
4.3	0.216%	0.243%	0.107%	0.083%	0.068%	0.057%	0.050%	0.048%	0.046%	0.051%	0.052%
4.5	0.289%	0.261%	0.103%	0.075%	0.060%	0.054%	0.046%	0.042%	0.037%	0.038%	0.038%
4.7	0.308%	0.190%	0.088%	0.071%	0.059%	0.055%	0.047%	0.042%	0.036%	0.034%	0.033%
4.9	0.214%	0.104%	0.064%	0.056%	0.050%	0.050%	0.048%	0.044%	0.037%	0.034%	0.032%
5.1	0.105%	0.062%	0.050%	0.047%	0.043%	0.043%	0.046%	0.046%	0.040%	0.038%	0.033%
5.3	0.066%	0.049%	0.040%	0.039%	0.038%	0.038%	0.039%	0.043%	0.042%	0.041%	0.039%
5.5	0.050%	0.040%	0.032%	0.032%	0.030%	0.032%	0.033%	0.037%	0.038%	0.039%	0.042%
5.7	0.041%	0.034%	0.029%	0.028%	0.025%	0.027%	0.028%	0.030%	0.030%	0.034%	0.038%
5.9	0.035%	0.032%	0.028%	0.026%	0.025%	0.024%	0.026%	0.024%	0.024%	0.028%	0.036%
6.1	0.029%	0.029%	0.025%	0.024%	0.023%	0.024%	0.022%	0.022%	0.020%	0.024%	0.061%
6.3	0.024%	0.025%	0.023%	0.022%	0.022%	0.021%	0.020%	0.021%	0.020%	0.026%	0.111%
6.5	0.022%	0.023%	0.021%	0.020%	0.020%	0.020%	0.019%	0.020%	0.020%	0.055%	0.128%
6.7	0.019%	0.021%	0.020%	0.020%	0.019%	0.018%	0.019%	0.019%	0.020%	0.101%	0.046%
6.9	0.017%	0.019%	0.019%	0.019%	0.017%	0.017%	0.018%	0.019%	0.021%	0.132%	0.022%
7.1	0.017%	0.018%	0.017%	0.017%	0.017%	0.017%	0.017%	0.019%	0.027%	0.066%	0.020%
7.3	0.017%	0.018%	0.016%	0.016%	0.016%	0.016%	0.017%	0.020%	0.061%	0.026%	0.019%
7.5	0.020%	0.020%	0.018%	0.018%	0.017%	0.016%	0.020%	0.036%	0.101%	0.019%	0.018%
7.7	0.020%	0.020%	0.018%	0.018%	0.018%	0.019%	0.044%	0.080%	0.118%	0.017%	0.017%
7.9	0.016%	0.016%	0.016%	0.018%	0.022%	0.032%	0.086%	0.121%	0.059%	0.015%	0.015%
8.1	0.015%	0.017%	0.019%	0.031%	0.057%	0.071%	0.121%	0.092%	0.023%	0.014%	0.015%
8.3	0.017%	0.023%	0.040%	0.078%	0.092%	0.113%	0.079%	0.029%	0.015%	0.014%	0.014%
8.5	0.024%	0.063%	0.081%	0.110%	0.122%	0.099%	0.025%	0.015%	0.015%	0.014%	0.014%
8.7	0.065%	0.095%	0.113%	0.093%	0.053%	0.029%	0.015%	0.014%	0.013%	0.013%	0.014%
8.9	0.094%	0.115%	0.080%	0.033%	0.019%	0.015%	0.013%	0.013%	0.013%	0.014%	0.013%

4.7		Table: Power factor						P	
Unity Power Factor (PF=1.0)									
P/Pn[%] setpoint	P[KW]	Q[KVar]	Cosφ	Cosφ Set-point	Δcosφ	Q[KVar] setpoint	ΔQ/P <sub>n</sub> [%]	LIMITE ΔQ[%]	
10	0.65	0.24	0.9377	1.00	-0.0623	--	--	--	
20	1.30	0.24	0.9833	1.00	-0.0167	0	3.71%	5	
30	1.96	0.25	0.9922	1.00	-0.0078	0	3.77%	5	
40	2.60	0.24	0.9958	1.00	-0.0042	0	3.69%	5	
50	3.25	0.25	0.9970	1.00	-0.0030	0	3.88%	5	
60	3.90	0.27	0.9976	1.00	-0.0024	0	4.16%	5	
70	4.55	0.27	0.9982	1.00	-0.0018	0	4.20%	5	
80	5.19	0.28	0.9986	1.00	-0.0014	0	4.25%	5	
90	5.83	0.28	0.9988	1.00	-0.0012	0	4.35%	5	
100	6.42	0.29	0.9990	1.00	-0.0010	0	4.45%	5	
Power Factor (PF=0.95 Inductive)									
P/Pn[%] setpoint	P[KW]	Q[KVar]	Cosφ	Cosφ Set-point	Δcosφ	Q[KVar] setpoint	ΔQ/P <sub>n</sub> [%]	LIMITE ΔQ[%]	
10	0.65	-0.26	-0.9242	-0.95	0.0258	--	--	--	
20	1.31	-0.46	-0.9412	-0.95	0.0088	-0.43	-0.57%	5	
30	1.96	-0.66	-0.9465	-0.95	0.0035	-0.64	-0.32%	5	
40	2.61	-0.89	-0.9461	-0.95	0.0039	-0.85	-0.53%	5	
50	3.26	-1.08	-0.9488	-0.95	0.0012	-1.07	-0.19%	5	
60	3.91	-1.30	-0.9484	-0.95	0.0016	-1.28	-0.33%	5	
70	4.56	-1.51	-0.9492	-0.95	0.0008	-1.50	-0.19%	5	
80	5.20	-1.71	-0.9499	-0.95	0.0001	-1.71	-0.02%	5	
90	5.85	-1.93	-0.9498	-0.95	0.0002	-1.92	-0.04%	5	
100	6.50	-2.14	-0.9500	-0.95	0.0000	-2.14	0.00%	5	

Power Factor (PF=0.95 Capacitive)								
P/Pn[%] setpoint	P[KW]	Q[KVar]	Cosφ	Cosφ Set-point	Δcosφ	Q[KVar] setpoint	ΔQ/P <sub>n</sub> [%]	LIMITE ΔQ[%]
10	0.65	0.19	0.9490	0.95	-0.0010	--	--	--
20	1.30	0.39	0.9550	0.95	0.0050	0.43	-0.63%	5
30	1.95	0.60	0.9544	0.95	0.0044	0.64	-0.63%	5
40	2.60	0.80	0.9548	0.95	0.0048	0.85	-0.85%	5
50	3.25	1.00	0.9557	0.95	0.0057	1.07	-1.12%	5
60	3.90	1.21	0.9545	0.95	0.0045	1.28	-1.06%	5

70	4.55	1.45	0.9526	0.95	0.0026	1.50	-0.72%	5
80	5.19	1.66	0.9523	0.95	0.0023	1.71	-0.76%	5
90	5.81	1.85	0.9527	0.95	0.0027	1.92	-1.14%	5
100	5.97	1.90	0.9528	0.95	0.0028	2.14	-3.65%	5

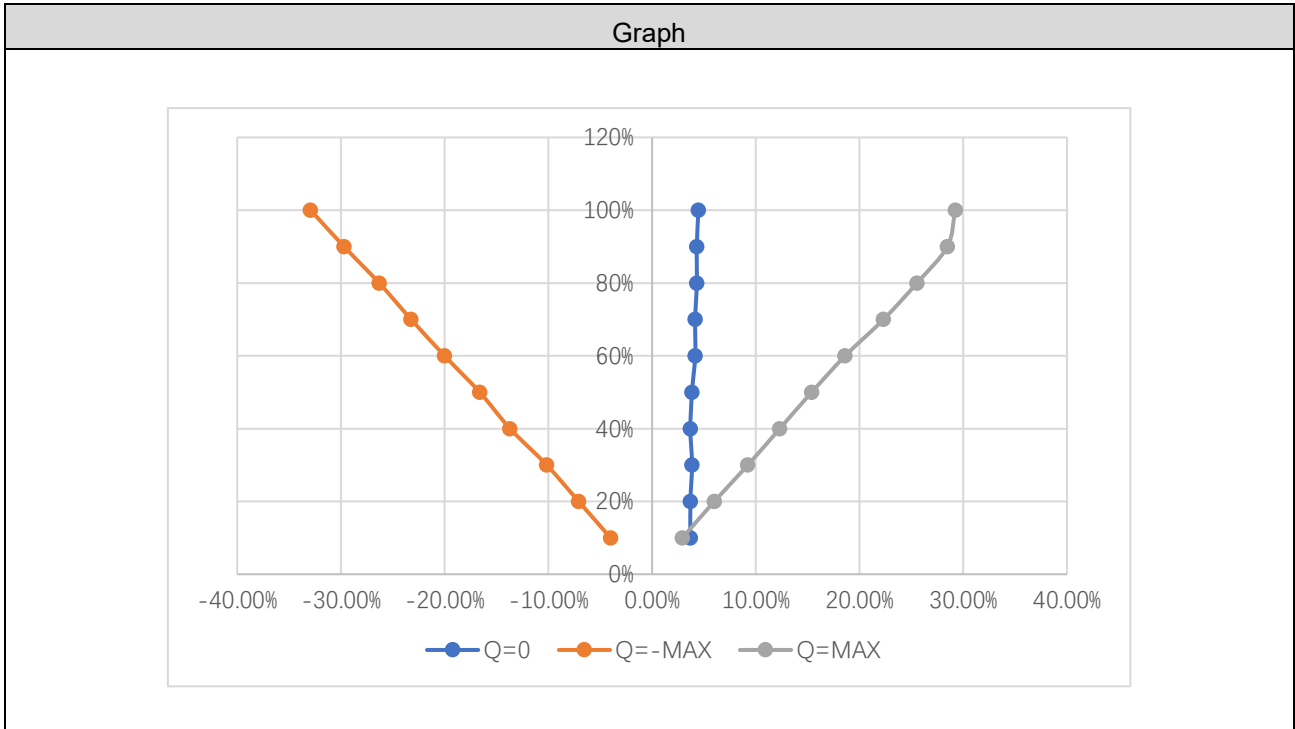

5.2.15	Table: Safety disconnect unit - Overvoltage and undervoltage	P
5.2.16		

**Table 3 — Protection functions and response times**

1	2
Protection function	Maximum trip time
V < 50 %	0,2 s
50 % ≤ V < 85 %	10 s
85 % ≤ V ≤ 110 %	Continuous operation
110 % < V < 115 %	40 s
115% ≤ V < 120%	2 s
120 % ≤ V	0,16 s
f < 47 Hz	0,2 s
f > 51,5 Hz	4 s
RoCoF > 1,5 Hz/s	2 s

**NOTE** It can be assumed that the electromechanical switch will operate within 0,1 s after receiving a signal from the protection relay. The protection function should therefore be set to respond 0,1 s faster than the maximum trip times.

Voltage level	Voltage Setting (p.u.)	Voltage Trip (p.u.)	Deviation (within ±0.01)	Trip time limit (ms)	Time measured (ms)
<b>U &lt; 50% Un</b>	0.500	0.494	-0.006	200	177
<b>U &lt; 85% Un</b>	0.850	0.846	-0.004	10000	9974
<b>U &gt; 110% Un</b>	1.100	1.102	0.002	40000	39965
<b>U &gt; 115% Un</b>	1.150	1.153	0.003	2000	1932
<b>U &gt; 120% Un</b>	1.200	1.201	0.001	160	141

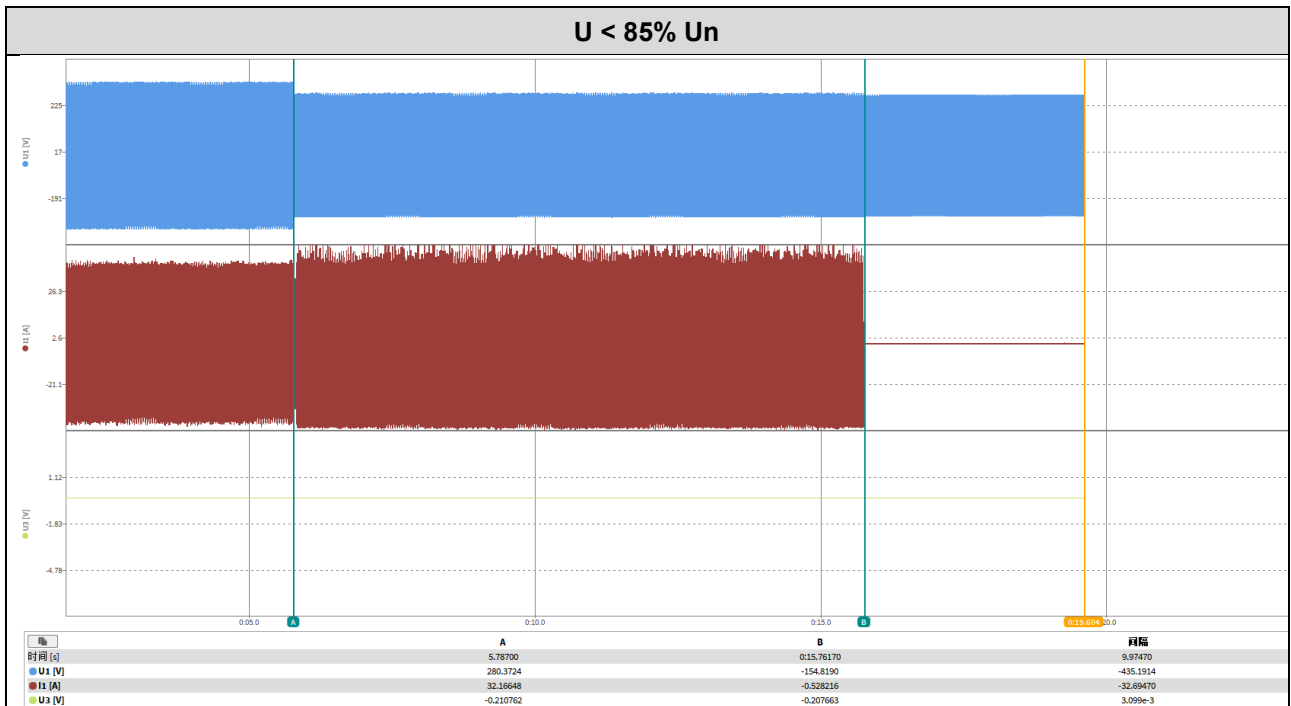
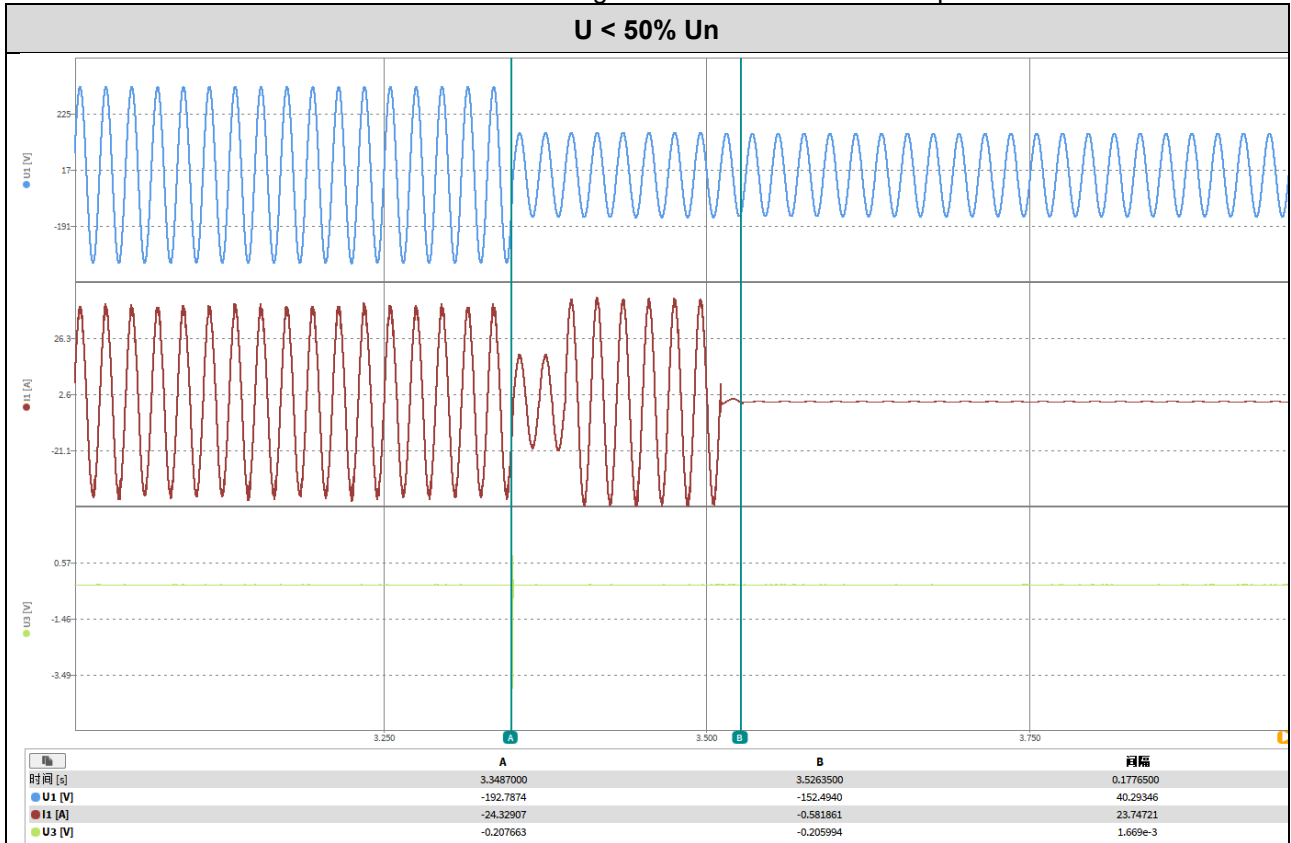

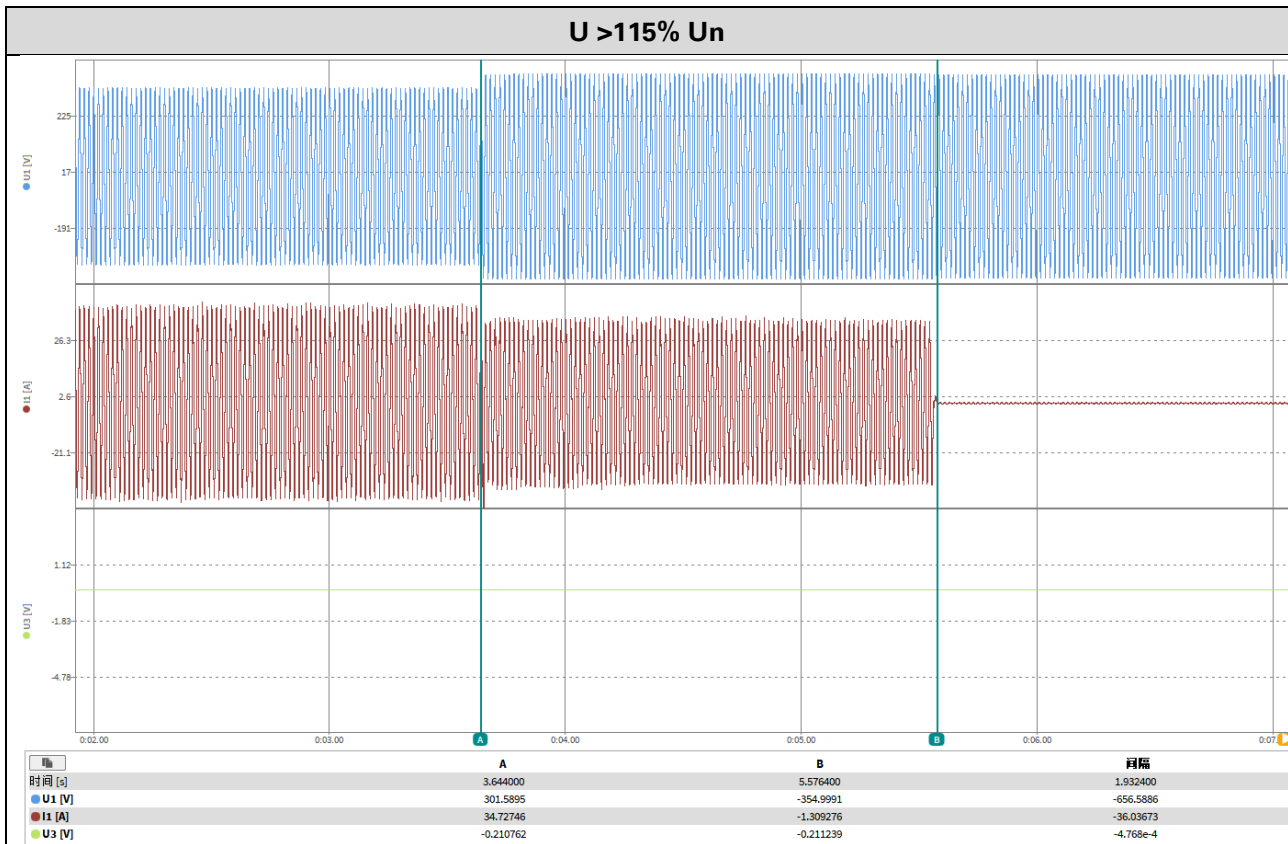
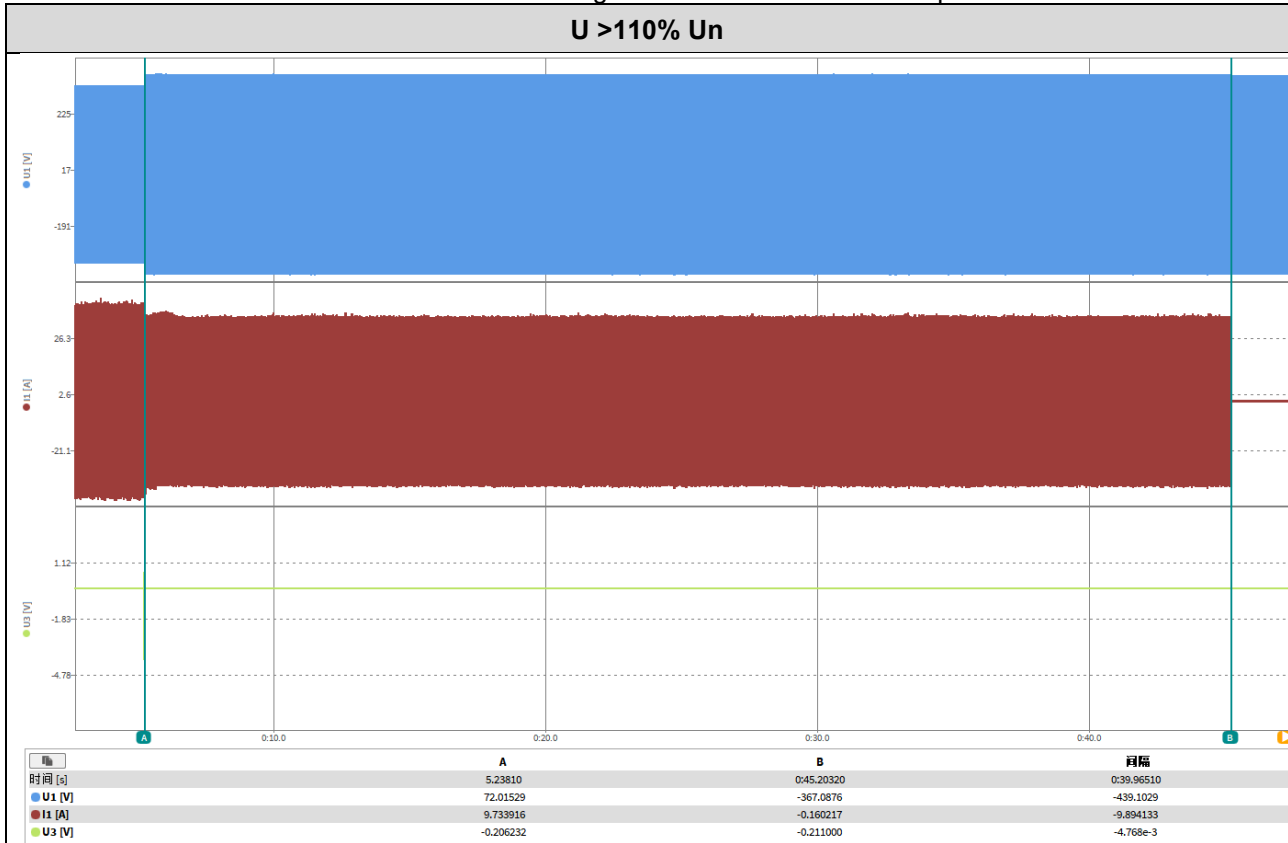

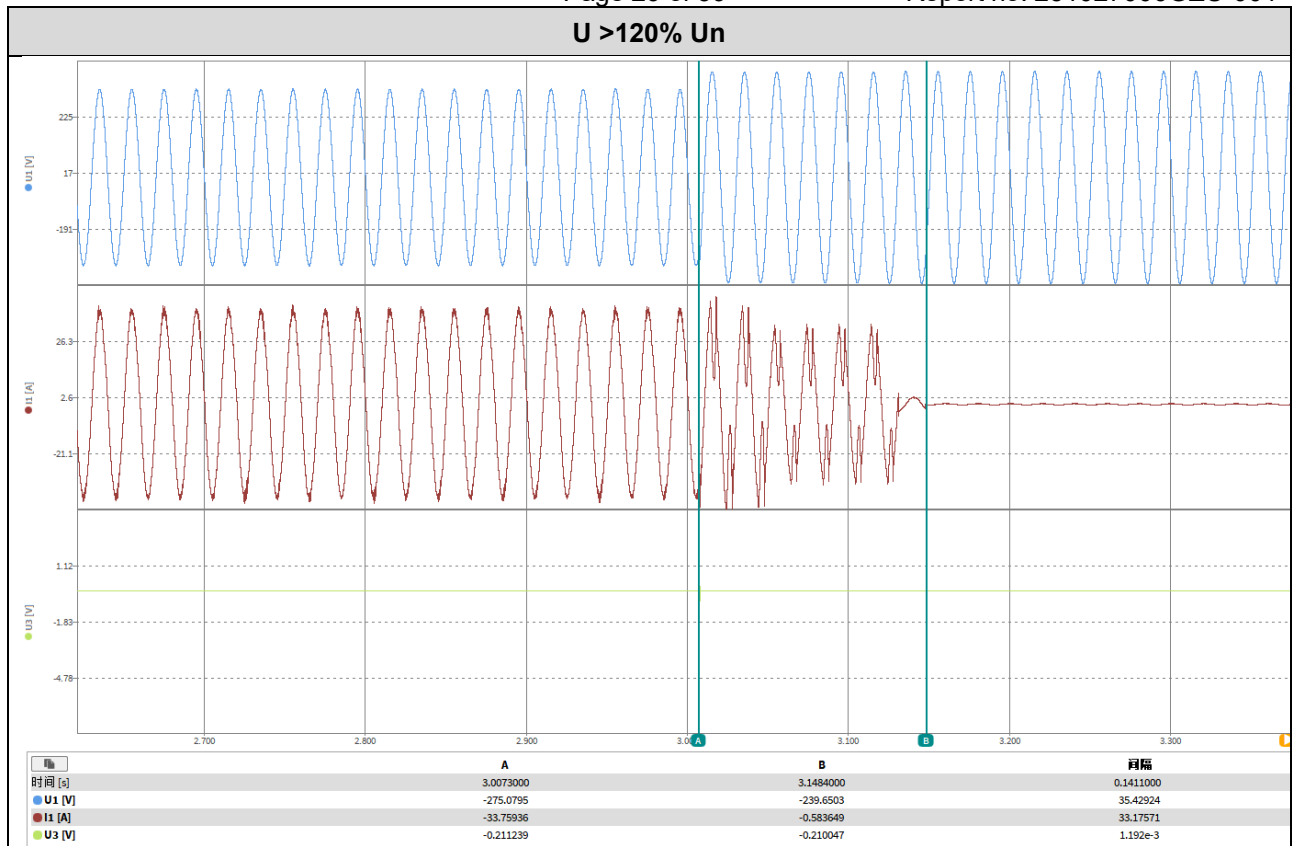

<p>5.2.15 5.2.16</p>	<p>Table: Safety disconnect unit - Overfrequency and underfrequency</p>	<p>P</p>
--------------------------	---	----------

**Table 3 — Protection functions and response times**

1	2
<b>Protection function</b>	<b>Maximum trip time</b>
V < 50 %	0,2 s
50 % ≤ V < 85 %	10 s
85 % ≤ V ≤ 110 %	Continuous operation
110 % < V < 115 %	40 s
115% ≤ V < 120%	2 s
120 % ≤ V	0,16 s
f < 47 Hz	0,2 s
f > 51,5 Hz	4 s
RoCoF > 1,5 Hz/s	2 s

NOTE It can be assumed that the electromechanical switch will operate within 0,1 s after receiving a signal from the protection relay. The protection function should therefore be set to respond 0,1 s faster than the maximum trip times.

Frequency	Frequency Setting (Hz)	Frquency Trip (Hz)	Deviation (within ±0.1Hz)	Trip time limit (s)	Time measured (s)
f < 47Hz	47.00	46.96	0.04	0.2	179
f > 51.5Hz	51.50	51.55	0.05	4.0	3646

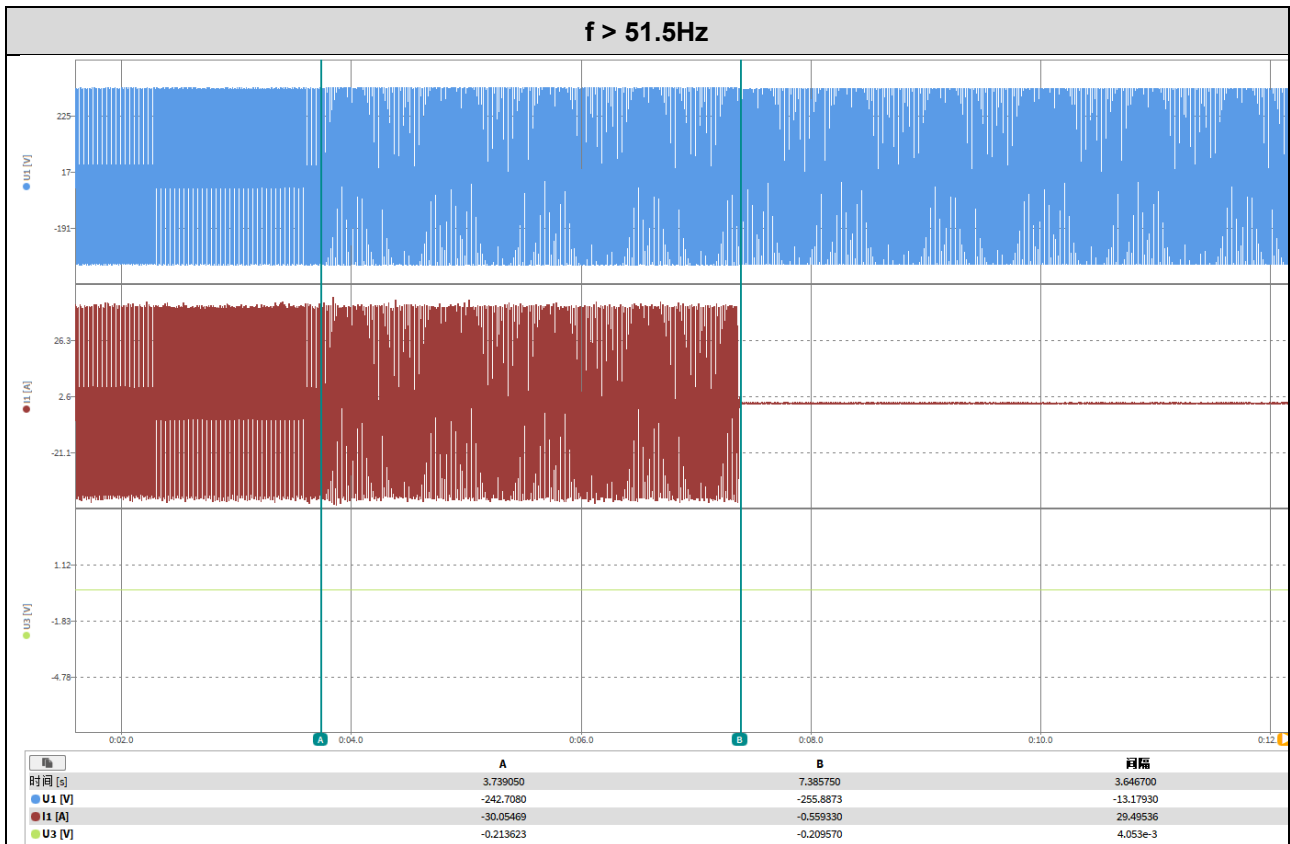
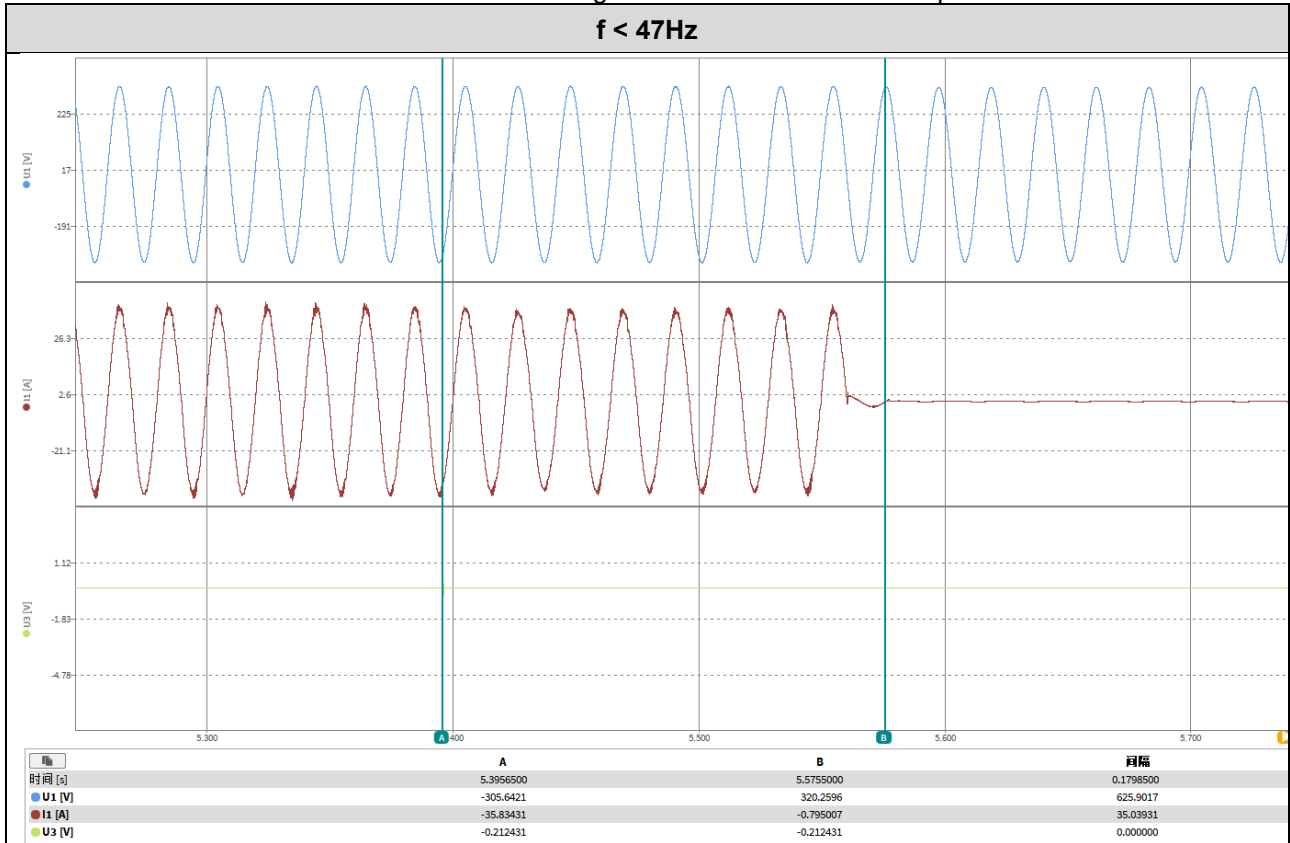

4.8 & 5.6		Table: Synchronization and reconnection Response to utility recovery			P
No connection Or Disconnection		Connection after 60 sec		Connection time (s)	Rising curve of 10%Pn/min
U > 110% Un	Yes	85% Un < U < 110 % Un	Yes	60.3	9.19%Pn/min
U < 85% Un	Yes	85% Un < U < 110 % Un	Yes	62.0	9.32%Pn/min
f > 51.5 Hz	Yes	47.00 Hz < f < 51.5 Hz	Yes	61.5	9.28%Pn/min
f < 47.00 Hz	Yes	47.00Hz < f < 51.5 Hz	Yes	60.7	9.27%Pn/min

Recovery after Over voltage, Graph

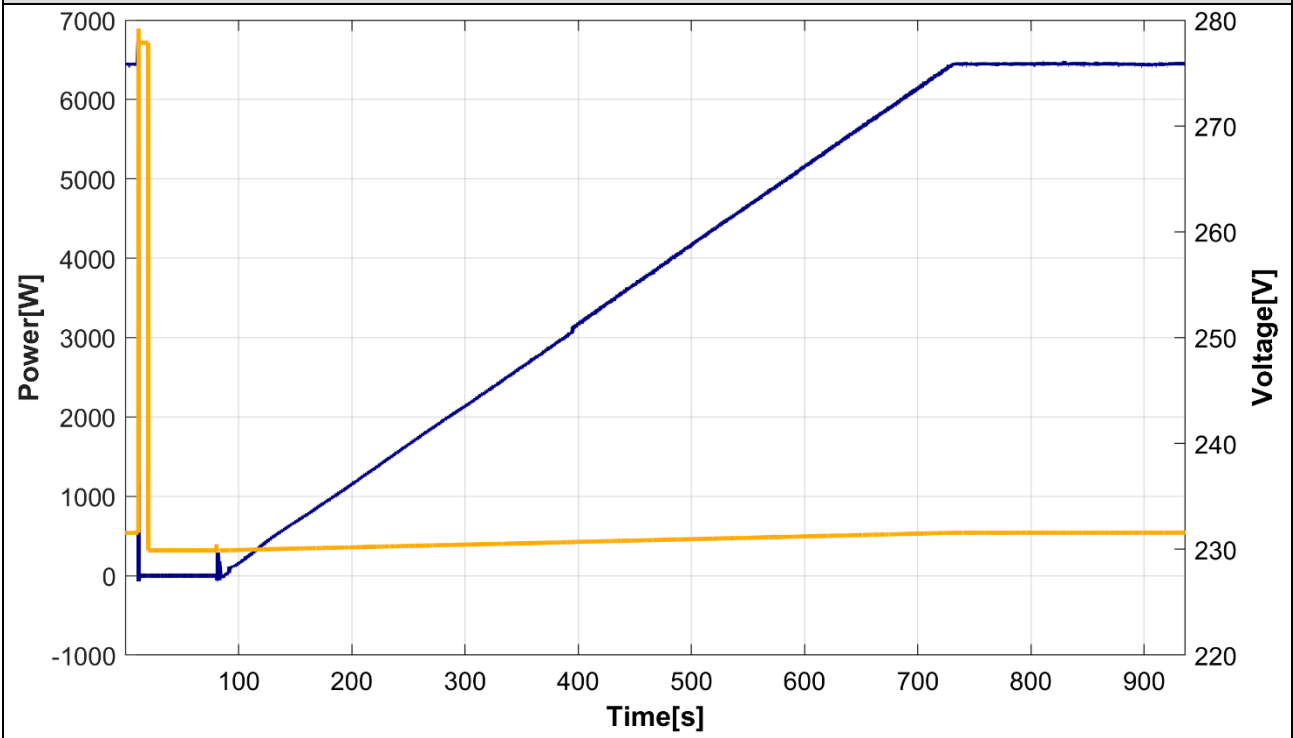

Recovery after under voltage, Graph

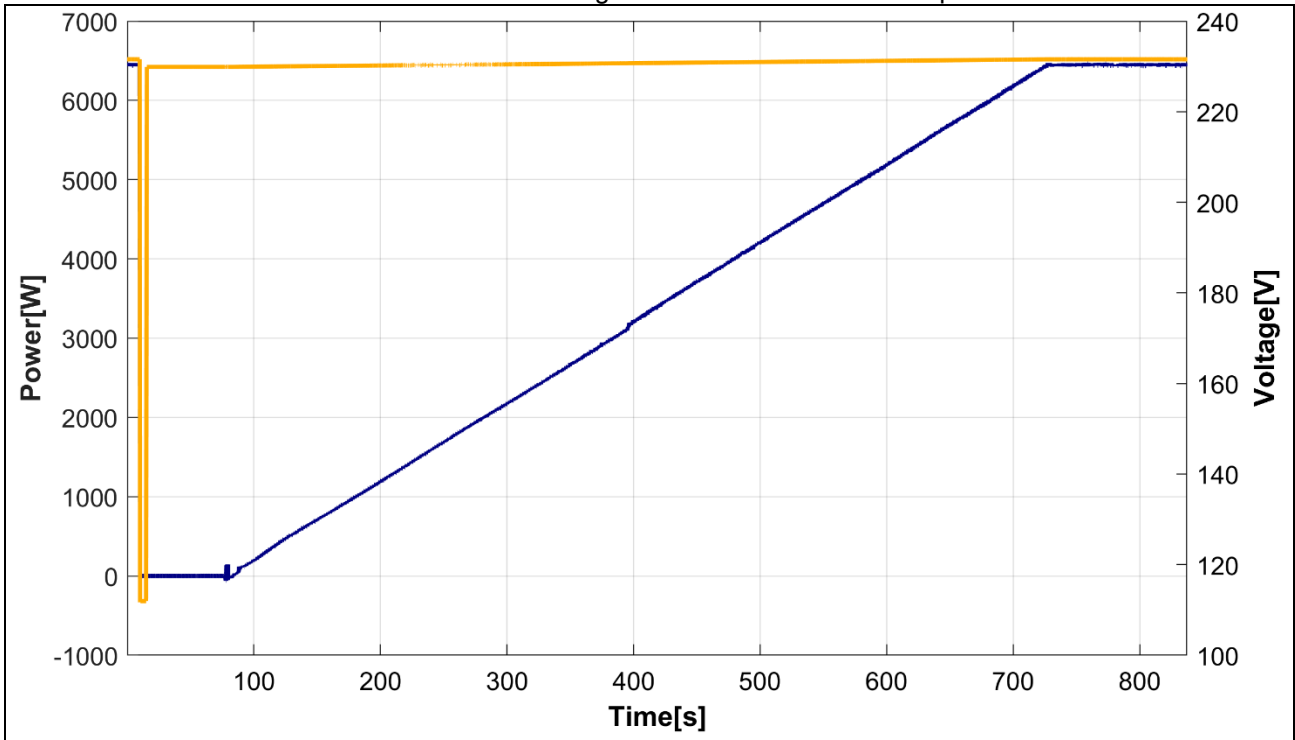

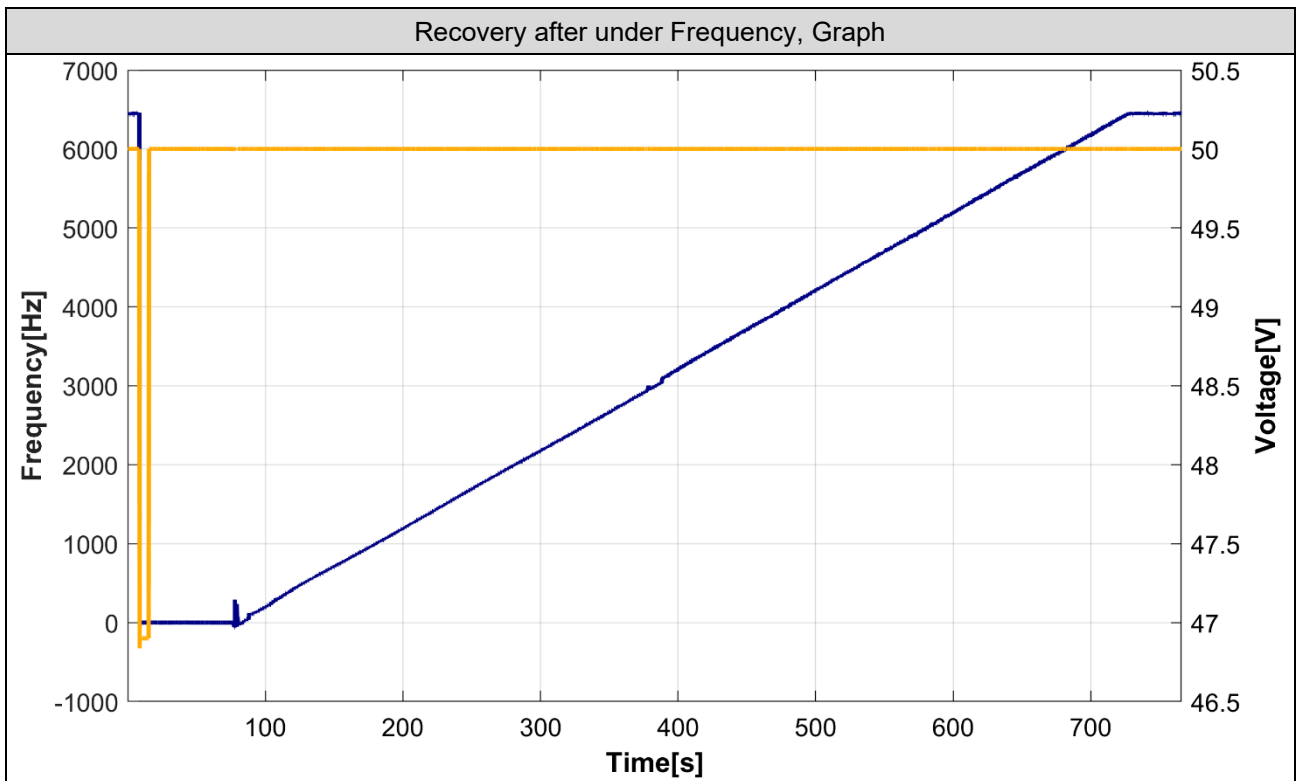
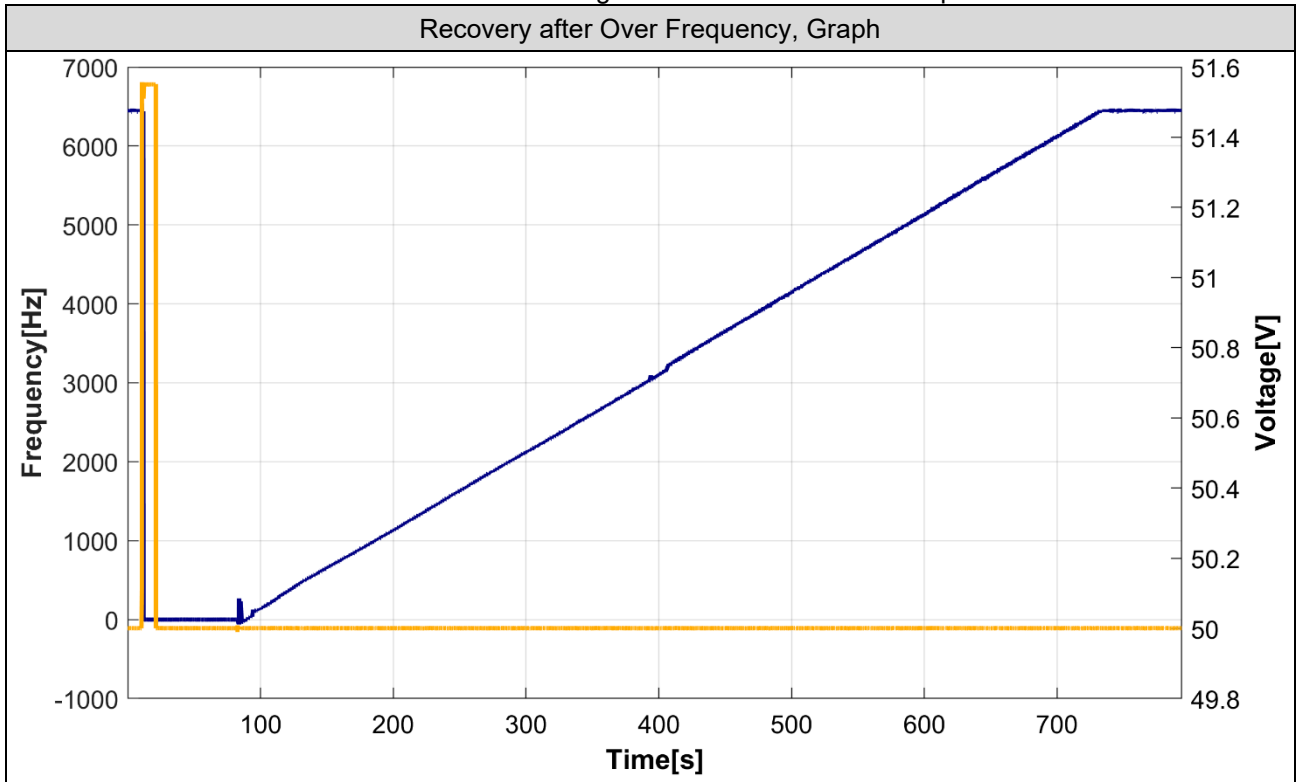

5.3 Prevention of forming an unintentional island on the utility side (comply with IEC 62116)									P
No.	PEUT <sup>1)</sup> (% of EUT rating)	Reactive load (% of QL in 6.1.d)1)	PAC <sup>2)</sup> (% of nominal)	QAC <sup>3)</sup> (% of nominal)	Run on time (ms)	PEUT (kW)	Actual Qf	VDC	Remarks <sup>4)</sup>
1	100	100	0	0	229	6.5	1.002	320	Test A at BL
2	66	66	0	0	270	4.3	1.002	240	Test B at BL
3	33	33	0	0	319	2.1	0.992	144	Test C at BL
4	100	100	-5	-5	136	6.5	0.978	320	Test A at IB
5	100	100	-5	0	124	6.5	0.965	320	Test A at IB
6	100	100	-5	5	139	6.5	0.942	320	Test A at IB
7	100	100	0	-5	161	6.5	1.015	320	Test A at IB
8	100	100	0	5	153	6.5	0.981	320	Test A at IB
9	100	100	5	-5	161	6.5	1.073	320	Test A at IB
10	100	100	5	0	152	6.5	1.059	320	Test A at IB
11	100	100	5	5	153	6.5	1.035	320	Test A at IB
12	66	66	0	-5	292	4.3	1.023	240	Test B at IB
13	66	66	0	-4	338	4.3	1.018	240	Test B at IB
14	66	66	0	-3	305	4.3	1.013	240	Test B at IB
15	66	66	0	-2	374	4.3	1.007	240	Test B at IB
16	66	66	0	-1	317	4.3	1.007	240	Test B at IB
17	66	66	0	1	158	4.3	0.996	240	Test B at IB
18	66	66	0	2	136	4.3	0.994	240	Test B at IB
19	66	66	0	3	162	4.3	0.989	240	Test B at IB
20	66	66	0	4	187	4.3	0.981	240	Test B at IB
21	66	66	0	5	161	4.3	0.974	240	Test B at IB
22	33	33	0	-5	261	4.3	1.018	144	Test C at IB
23	33	33	0	-4	280	4.3	1.008	144	Test C at IB
24	33	33	0	-3	321	4.3	1.008	144	Test C at IB
25	33	33	0	-2	143	4.3	1.008	144	Test C at IB
26	33	33	0	-1	494	4.3	0.991	144	Test C at IB
27	33	33	0	1	119	4.3	0.982	144	Test C at IB
28	33	33	0	2	155	4.3	0.982	144	Test C at IB
29	33	33	0	3	157	4.3	0.986	144	Test C at IB
30	33	33	0	4	169	4.3	0.969	144	Test C at IB
31	33	33	0	5	101	4.3	0.969	144	Test C at IB

Remark:

- 1) PEUT: EUT output power
- 2) PAC: Real power flow at S1 in Figure 1. Positive means power from EUT to utility. Nominal is the 0% test condition value.
- 3) QAC: Reactive power flow at S1 in Figure 1. Positive means power from EUT to utility. Nominal is the 0% test condition value.
- 4) BL: Balance condition, IB: Imbalance condition.
- 5) \*Note: test condition A (100%): If any of the recorded run-on times are longer than the one recorded for the rated balance condition, i.e. test procedure 6.1 f), then the non-shaded parameter combinations (no.32~47) also require testing.

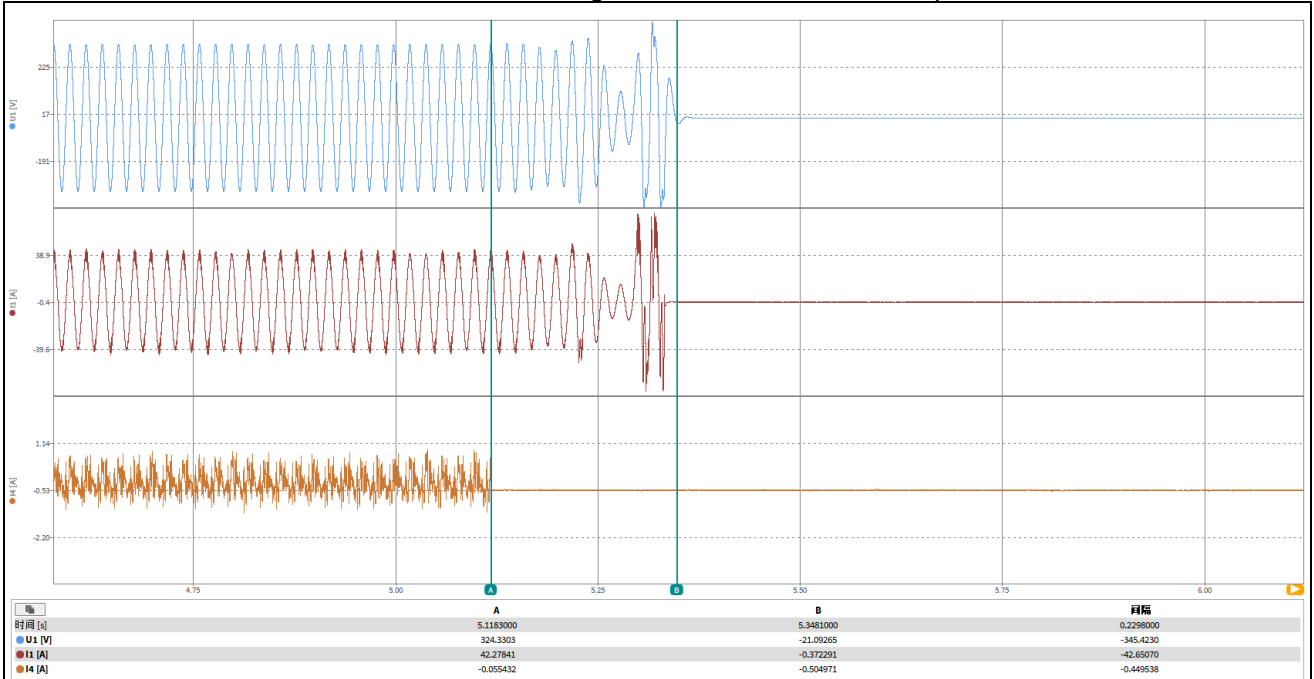

PEUT 100%, PAC 0%, QAC 0%, = 229ms

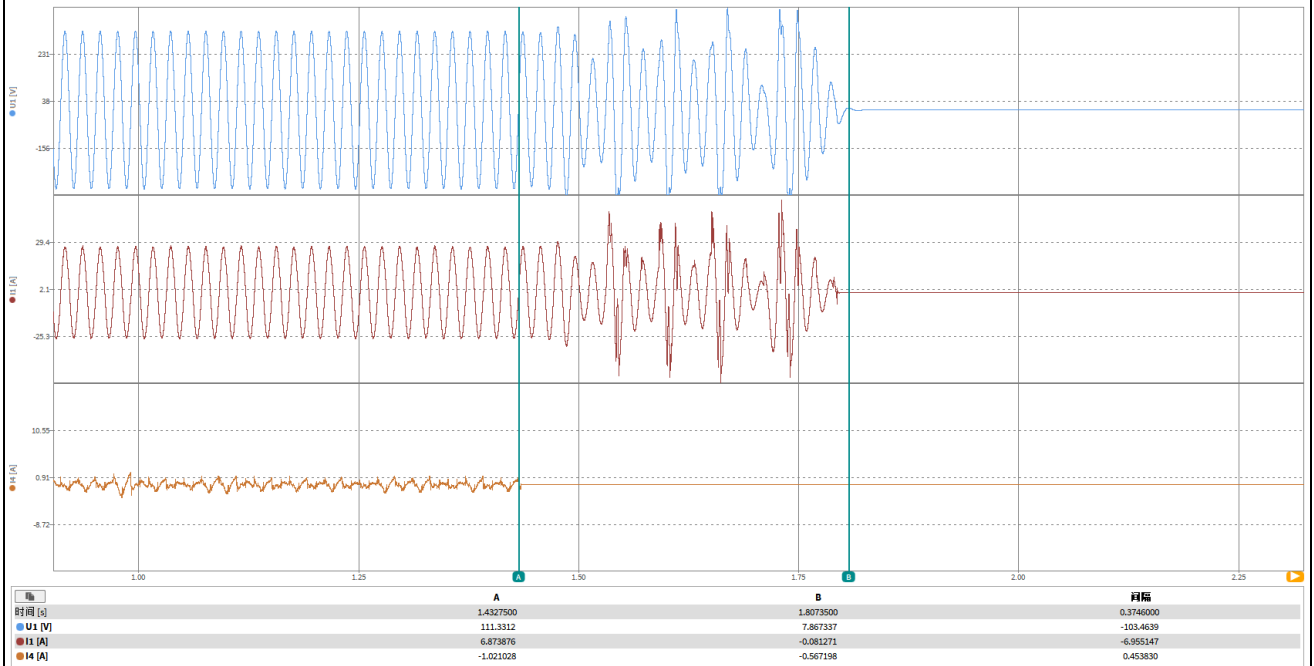

PEUT 66%, PAC 0%, QAC -2%, = 374ms

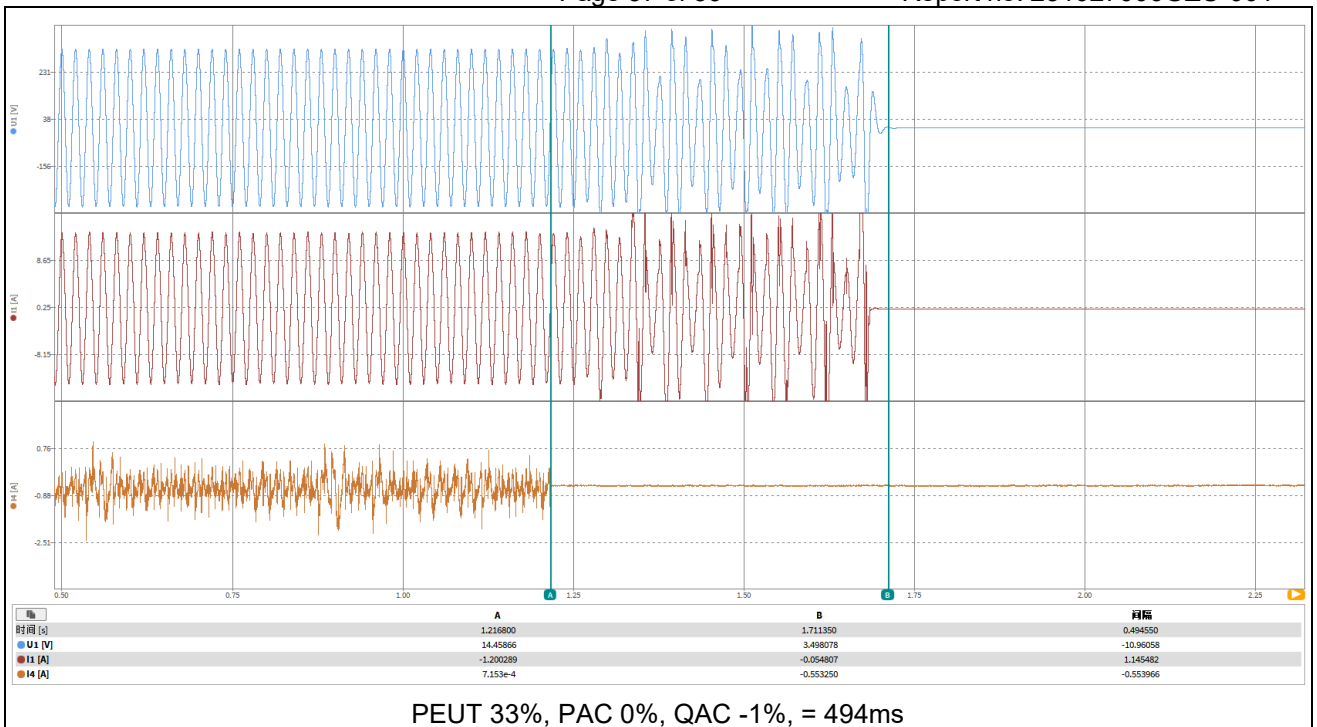

Appendix: Photos



Over view

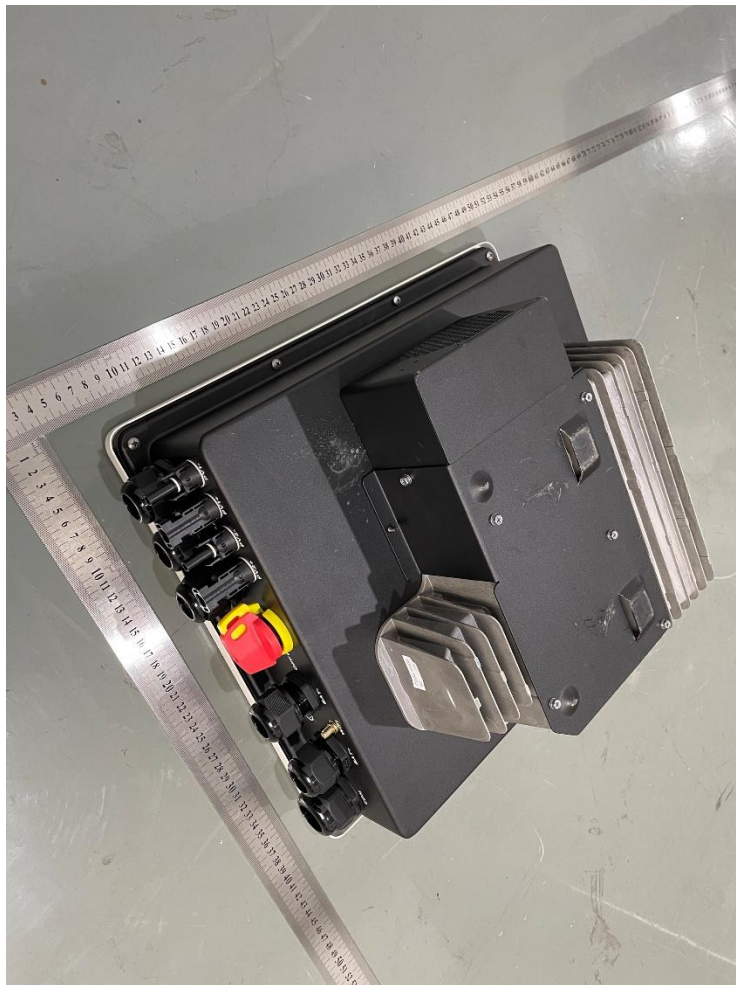

Bottom view



Connection view

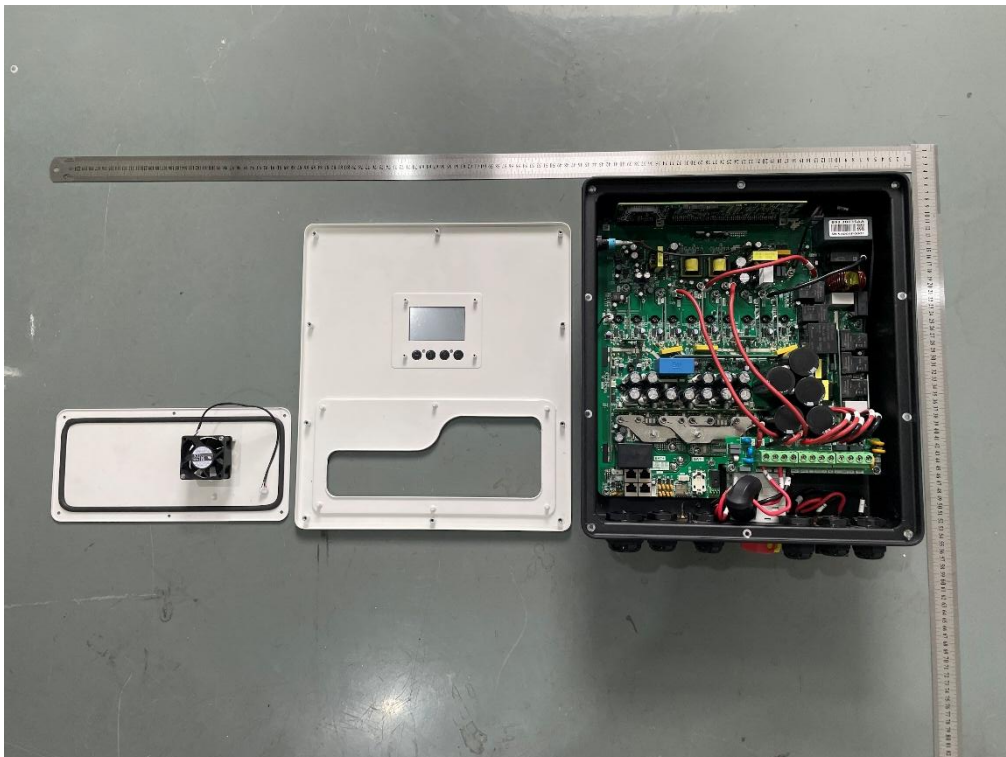

Internal view  
(End of Report)